

# UNH/NOAA Joint Hydrographic Center 2019 Performance and Progress Report



NOAA Grant No: NA15NOS4000200

Project Title: Joint Hydrographic Center

Reporting Period: 01/01/2019–12/31/2019

Principal Investigator: Larry A. Mayer

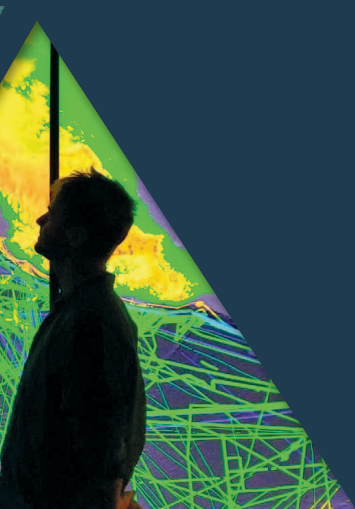
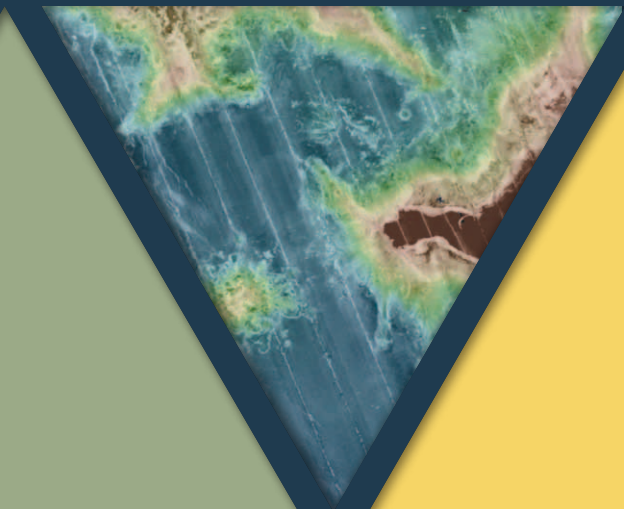

Center for Ocean and Coastal Mapping / Joint Hydrographic Center  
Center for Ocean Engineering  
SEMINAR SERIES

**Going to the Ends of the Earth**  
*Exploring Climate Change in Polar Regions*

Julie M. Palais, Ph.D.  
Division of Polar Programs  
National Science Foundation

Friday, September 27, 2019  
10:00 p.m.  
Jere A. Chase Ocean Engineering Lab  
Room 105

ALL ARE WELCOME!

Center for Ocean and Coastal Mapping / Joint Hydrographic Center  
Center for Ocean Engineering  
SEMINAR SERIES

**The Effect of Ocean Mapping  
Multibeam Echosounder Signals  
on Beaked Whales and  
the Acoustic Environment**

Hilary Kates Varghese  
Ph.D. Proposal Defense  
Dept. of Earth Sciences, Oceanography  
University of New Hampshire

Tuesday, October 15, 2019  
8:00 p.m.  
Jere A. Chase Ocean  
Engineering Lab  
Room 130

ALL ARE WELCOME!

Center for Ocean and Coastal Mapping / Joint Hydrographic Center  
Center for Ocean Engineering  
SEMINAR SERIES

**Port Decision Makers' Barriers to  
Climate and Extreme Weather Adaptation**

Elizabeth L. McLean, Ph.D.  
Environmental Scientist, Research Associate  
Marine Affairs Department  
University of Rhode Island

Friday, May 3, 2019  
3:10 p.m.  
Jere A. Chase Ocean Engineering Lab  
Room 105

ALL ARE WELCOME!

Center for Ocean and Coastal Mapping / Joint Hydrographic Center  
Center for Ocean Engineering  
SEMINAR SERIES

**Lidar Measurements of  
Nearshore Waves,  
Setup, Swash, and Dune Erosion**

Dr. Britt Raubenheimer  
Senior Scientist  
Woods Hole  
Oceanographic Institution

Friday, April 26, 2019  
3:10 p.m.  
Jere A. Chase  
Ocean Engineering Lab  
Room 105

ALL ARE WELCOME!

Center for Ocean and Coastal Mapping / Joint Hydrographic Center  
Center for Ocean Engineering  
SEMINAR SERIES

**Acoustic Methods for Mapping and Characterizing  
Submerged Aquatic Vegetation  
Using a Multi-Beam Echosounder**

Ashley Norton  
Ph.D. Dissertation Defense  
Natural Resource and Earth System Science  
University of New Hampshire

Friday, November 22, 2019  
10:00 a.m.  
Jere A. Chase Ocean Engineering Lab  
Room 130

ALL ARE WELCOME!

Center for Ocean and Coastal Mapping / Joint Hydrographic Center  
Center for Ocean Engineering  
SEMINAR SERIES

**A Method of Improving  
the Physical Layer for  
Digital Acoustic Communications**

Arthur B. Baggeroer  
Ford Professor of Engineering, Emeritus  
Mechanical Engineering  
Electrical Engineering & Computer Science  
Massachusetts Institute of Technology

Friday, April 12, 2019  
3:10 p.m.  
Jere A. Chase Ocean Engineering Lab  
Room 105

ALL ARE WELCOME!

Center for Ocean and Coastal Mapping / Joint Hydrographic Center  
Center for Ocean Engineering  
SEMINAR SERIES

**Beyond Telepresence**  
*Innovations from the Inner Space Center*

Colleen Peters  
Marketing & Operations Specialist  
Inner Space Center  
University of Rhode Island

Friday, October 4, 2019  
3:10 p.m.  
Jere A. Chase  
Ocean Engineering Lab  
Room 105

ALL ARE WELCOME!

Center for Ocean and Coastal Mapping / Joint Hydrographic Center  
Center for Ocean Engineering  
SEMINAR SERIES

**Better Shallow-water Bathymetric Maps from  
Airborne Lidar Data Using Machine Learning**

Dr. Eric Leonard  
Research Scientist  
CCOM/JHC  
University of New Hampshire

Friday, April 19, 2019  
3:10 p.m.  
Jere A. Chase Ocean Engineering Lab  
Room 105

ALL ARE WELCOME!

Center for Ocean and Coastal Mapping / Joint Hydrographic Center  
Center for Ocean Engineering  
SEMINAR SERIES

**Bipolar Robotics**  
*From the Arctic to the Antarctic with a  
Stop for Fisheries in the Middle Latitudes*

Professor Hanumant Singh  
Director  
Center for Robotics  
Northeastern University

Friday, March 8, 2019  
3:10 p.m.  
Jere A. Chase  
Ocean Engineering Lab  
Room 105

ALL ARE WELCOME!

Center for Ocean and Coastal Mapping / Joint Hydrographic Center  
Center for Ocean Engineering  
SEMINAR SERIES

**Geological Carbon Storage Monitoring**

Scott Løwinger, Ph.D.  
Postdoctoral Research Fellow  
Norwegian Geotechnical Institute

Friday, October 11, 2019  
3:10 p.m.  
Jere A. Chase Ocean Engineering Lab  
Room 105

ALL ARE WELCOME!

Center for Ocean and Coastal Mapping / Joint Hydrographic Center  
Center for Ocean Engineering  
SEMINAR SERIES

**Impressed Current Cathodic  
Protection (ICCP) Systems  
in Marine Environments**

Chris Sullivan, PE  
System Engineer  
Portsmouth Naval Shipyard

Friday, November 15, 2019  
3:10 p.m.  
Jere A. Chase Ocean Engineering Lab  
Room 105

ALL ARE WELCOME!

Center for Ocean and Coastal Mapping / Joint Hydrographic Center  
Center for Ocean Engineering  
SEMINAR SERIES

**Laser-Based Sensing  
in Aqueous Environments**

Dr. Anwa Michal  
Associate Scientist  
Applied Ocean Physics and Engineering  
Woods Hole Oceanographic Institution

Friday, February 1, 2019  
3:10 p.m.  
Jere A. Chase Ocean Engineering Lab  
Room 105

ALL ARE WELCOME!

Center for Ocean and Coastal Mapping / Joint Hydrographic Center  
Center for Ocean Engineering  
SEMINAR SERIES

**Beyond Break the Grip**  
*Rip Current Forecasting and Communication at NOAA*

Dr. Greg Dusek  
Senior Scientist  
NOAA National Ocean Service

Friday, October 25, 2019  
3:10 p.m.  
Jere A. Chase Ocean Engineering Lab  
Room 105

ALL ARE WELCOME!

Center for Ocean and Coastal Mapping / Joint Hydrographic Center  
Center for Ocean Engineering  
SEMINAR SERIES

**High Frequency  
Motion Residuals**  
*Analysis and Estimation*

Brandon Maingot  
Thesis Defense  
Master of Science  
OE/Ocean Mapping

Tuesday, July 30, 2019  
2:00 p.m.  
Jere A. Chase  
Ocean Engineering Lab  
Room 130

ALL ARE WELCOME!

Center for Ocean and Coastal Mapping / Joint Hydrographic Center  
Center for Ocean Engineering  
SEMINAR SERIES

**Advances in Applications of  
Soft Robotics, Additive Manufacturing, and  
Distributed Sensing to Deep-Sea Research**

Brennon T. Phillips  
Assistant Professor  
URI Dept. of Ocean Engineering

Friday, November 1, 2019  
3:10 p.m.  
Jere A. Chase Ocean Engineering Lab  
Room 105

ALL ARE WELCOME!

Center for Ocean and Coastal Mapping / Joint Hydrographic Center  
Center for Ocean Engineering  
SEMINAR SERIES

**Measuring the  
Spatial Structure of  
Seaweed Habitats in a  
Changing Environment  
*Implication for the Food Web***

Jenn Dijkstra  
Research  
Assistant Professor  
Colin Ware  
Director of the  
Data Visualization Research Lab  
CCOM/JHC  
University of New Hampshire

Friday, January 25, 2019  
3:10 p.m.  
Jere A. Chase  
Ocean Engineering Lab  
Room 105

ALL ARE WELCOME!

Flyers from the 2019 JHC/CCOM – UNH Dept. of Ocean Engineering Seminar Series.



**EXECUTIVE SUMMARY ..... 5**

    INTRODUCTION ..... 5

    HIGHLIGHTS FROM OUR 2019 PROGRAM ..... 9

**INTRODUCTION..... 45**

**INFRASTRUCTURE..... 45**

    PERSONNEL..... 45

        Faculty ..... 46

        Research Scientists and Staff ..... 49

        NOAA Employees ..... 53

        Other Affiliated Faculty ..... 55

        Visiting Scholars ..... 59

    FACILITIES, IT, AND EQUIPMENT ..... 62

        Office and Teaching Space ..... 62

        Laboratory Facilities..... 63

        Pier Facilities ..... 66

        Information Technology ..... 66

        Research Vessels and Platforms..... 71

**STATUS OF RESEARCH: JANUARY–DECEMBER 2019..... 78**

    PROGRAMMATIC PRIORITY 1: INNOVATE HYDROGRAPHY..... 83

        Research Requirement 1.A: Data Collection ..... 83

        Research Requirement 1.B: Data Processing ..... 121

        Research Requirement 1.C: Seafloor Characterization, Habitat and Resources ..... 153

        Research Requirement 1.D: Third Party And Non-Traditional Data ..... 196

    PROGRAMMATIC PRIORITY 2: TRANSFORM CHARTING AND NAVIGATION ..... 201

        Research Requirement 2.A: Chart Adequacy and Computer-Assisted Cartography ..... 201

        Research Requirement 2.B: Comprehensive Charts and Decision Aids ..... 218

        Research Requirement 2.C: Visualization and Resource Management..... 226

    PROGRAMMATIC PRIORITY 3: EXPLORE AND MAP THE CONTINENTAL SHELF..... 231

        Research Requirement 3.A: Extended Continental Shelf..... 231

        Research Requirement 3.B: Ocean Exploration ..... 237

        Research Requirement 3.C: Telepresence and ROVS..... 249

PROGRAMMATIC PRIORITY 4: HYDROGRAPHIC EXPERTISE .....	250
Research Requirement 4.A: Education .....	250
Research Requirement 4.B: Acoustic Propagation and Marine Mammals .....	263
Research Requirement 4.C: Publications and R2O .....	274
Research Requirement 4.D: Outreach.....	274
APPENDIX A: GRADUATE DEGREES IN OCEAN MAPPING .....	293
APPENDIX B: FIELD PROGRAMS.....	297
APPENDIX C: PARTNERSHIPS AND ANCILLARY PROGRAMS.....	301
APPENDIX D: PUBLICATIONS.....	304
APPENDIX E: TECHNICAL PRESENTATIONS AND INVITED SEMINARS.....	308



The NOAA-UNH Joint Hydrographic Center (JHC/CCOM) was founded twenty years ago with the objective of developing tools and offering training that would help NOAA and others to meet the challenges posed by the rapid transition from the sparse measurements of depth offered by traditional sounding techniques (lead lines and single-beam echo sounders) to the massive amounts of data collected by the new generation of multibeam echo sounders. Over the years, the focus of research at the Center has expanded and now encompasses a broad range of ocean mapping technologies and applications, but at its roots, the Center continues to serve NOAA and the nation through the development of tools and approaches that support safe navigation, increase the efficiency of surveying, offer a range of value-added ocean mapping products, and ensure that new generations of hydrographers and ocean mappers receive state-of-the-art training.

An initial goal of the Center was to find ways to process the massive amounts of data generated by multibeam and sidescan sonar systems at rates commensurate with data collection; that is, to make the data ready for chart production as rapidly as the data were collected. We have made great progress over the years in attaining, and now far surpassing this goal, and while we continue our efforts on data processing in support of safe navigation, our attention has also turned to the opportunities provided by this huge flow of information to create a wide range of products that meet needs beyond safe navigation (e.g., marine habitat assessments, gas seep detection, fisheries management, disaster mitigation, and national security). Our approach to extracting “value added” from data collected in support of safe navigation was formalized with the enactment on the 30th of March 2009 of the Ocean and Coastal Mapping Integration Act—and our establishment of an Integrated Ocean and Coastal Mapping (IOCM) Processing Center at UNH to support NOAA and others in delivering the required products of this new legislation. In 2010 the concept of IOCM was clearly demonstrated when we were able to quickly and successfully apply tools and techniques developed for hydrographic and fisheries applications to the Deepwater Horizon oil spill crisis

In the time since our establishment, we have built a vibrant Center with an international reputation as the place, “where the cutting edge of hydrography is now located” (Adam Kerr, Past Director of the International Hydrographic Organization in Hydro International). In the words of Pat Sanders, then President of HYPACK Inc., a leading provider of hydrographic software to governments and the private sector:

*“JHC/CCOM has been THE WORLD LEADER in developing new processing techniques for hydrographic data. JHC/CCOM has also shown that they can quickly push new developments out into the marketplace, making both government and private survey projects more efficient and cost effective.”*

Since our inception, we have worked on the development of automated and statistically robust approaches to multibeam sonar data processing. These efforts came to fruition when our automated processing algorithm (CUBE) and our new database approach (The Navigation Surface), were, after careful verification and evaluation, accepted by NOAA, the Naval Oceanographic Office, and many other hydrographic agencies, as part of their standard processing protocols. Today, almost every hydrographic software manufacturer has incorporated these approaches into their products. It is not an overstatement to say that these techniques have revolutionized the way NOAA and others in the ocean mapping community are doing hydrography. These new techniques can reduce data processing time by a factor of 30 to 70 and provide a quantification of uncertainty that has never before been achievable in hydrographic data. The result has been: “gained efficiency, reduced costs, improved data quality and consistency, and the ability to put products in the hands of our customers faster.” (Capt. Roger Parsons, former NOAA IOCM Coordinator and Director of NOAA’s Office of Coast Survey).

The acceptance of CUBE and the Navigation Surface represents a paradigm shift for the hydrographic community—from dealing with individual soundings (reasonable in a world of lead line and single-beam sonar measurements) to the acceptance of gridded depth estimates (with associated uncertainty values) as a starting point for hydrographic products. The research needed to support this paradigm shift has been a focus of the Center since its inception and to now see it accepted is truly rewarding. It is also indicative of the role that the Center has played and will continue to play, in establishing new directions in hydrography and ocean mapping. The next generation of CUBE, CHRT (CUBE with Hierarchical Resolution Techniques) which supports the newly evolving concept of variable resolution grids, is currently being introduced to hydrographic community.

Another long-term theme of our research efforts has been our desire to extract information beyond depth (bathymetry) from the mapping systems used by NOAA and others. We have developed a simple-to-use tool (GeoCoder) that generates a sidescan-sonar or backscatter “mosaic,” a critical first step in the analysis of seafloor character. There has been tremendous interest in this software throughout NOAA, and many of our industrial partners have now incorporated GeoCoder into their software products. Like CUBE’s role in bathymetric processing, GeoCoder has become the standard approach to backscatter processing. An email message from a member of the Biogeography Team of NOAA’s Center for Coastal Monitoring and Assessment said:

*“We are so pleased with GeoCoder! We jumped in with both feet and made some impressive mosaics. Thanks so much for all the support.”*

While GeoCoder is focused on creating backscatter mosaics, BRESS (Bathymetry- and Reflectance-Based Approach for Seafloor Segmentation) provides tools for the segmentation and analysis of co-located bathymetry and backscatter, dividing the seafloor into a limited number of contiguous areas of similar morphology (land- or geoforms) and backscatter. This tool has found broad application in NOAA and others interested in defining seafloor habitat. BRESS is one of many tools developed at the Center that now form part of HydrOffice—an open-source collaborative effort led by the Center, in collaboration with NOAA, to develop a research software environment with applications to facilitate all phases of the ping-to-chart process. The environment facilitates the creation of new tools for researchers, students and in the field and speeds up both algorithm testing and the transfer from Research-to-Operation (R2O). Many of these tools are in daily use by NOAA field units, as well as scientists and researchers world-wide.

Beyond GeoCoder, BRESS, and the other HydrOffice tools, our efforts to support the IOCM concept of “map once, use many times” are also coming to fruition. Software developed by Center researchers has been installed on several NOAA fisheries vessels equipped with Simrad ME70 fisheries multibeam echo sounders. These sonars were originally designed for mapping pelagic fish schools but, using our software, the sonars are now being used for multiple seabed mapping purposes. For example, data collected on the NOAA Ship *Oscar Dyson* during an acoustic-trawl survey for walleye pollock was opportunistically processed for seabed characterization in support of essential fish habitat (EFH) and also in support of safety of navigation, including submission for charts and identification of a Danger to Navigation. Seafloor mapping data from the ME70 was used by fisheries scientists to identify optimal sites for fish-traps during a red snapper survey. Scientists aboard the ship said that the seafloor data provided by Center software was, “*invaluable in helping accomplish our trapping objectives on this trip.*” These tools are now being transitioned to our industrial partners so that fully supported commercial-grade versions of the software are available to NOAA. All of these examples (CUBE, GeoCoder, and our fisheries sonar tools) are tangible examples of our (and NOAA’s) goal of bringing our research efforts to operational practice (Research to Operations—R2O).

Ed Saade, President of Fugro (USA) Inc., in a statement for the record to the House Transportation and Infrastructure Subcommittee on Coast Guard and Maritime Transportation and Water Resources and Environment<sup>1</sup>, stated:

*“...R&D/Innovation initiatives at UNH CCOM JHC, have combined to be the leading technologies creators, developing Multibeam Echo Sounder (MBES) and related applications and improvements that have ultimately been adopted and applied, and which have extensively benefitted industry applications. Since the early 2000s, a small sampling list of such applications includes TrueHeave™, MBES Snippets, and Geocoder. This small sampling of applications integrated, into various seabed mapping industries in the United States alone, directly benefits more than \$200 million of mapping services annually.”*

The tools and products of the Center was also called upon to help with an international disaster—the mysterious loss of Air Malaysia Flight MH370. As part of our GEBCO/Nippon Foundation Bathymetric Training Program, researchers and students in the Center are compiling all available bathymetric data from the Indian Ocean. When MH370 was lost, the Government of Australia and several major media outlets came to the Center for the best available representations of the seafloor in the vicinity of the crash. The data we provided were used during the search and were displayed both on TV and in print media.

<sup>1</sup>Hearing on Federal Maritime Navigation Programs: Interagency Cooperation and Technological Change 19 September 2016. Fugro is the world’s largest survey company with more than 11,000 employees worldwide.



In the last few years, a new generation of multibeam sonars has been developed (in part as a result of research done at the Center) that have the capability of mapping targets in the water-column as well as the seafloor. We have been developing visualization tools that allow this water-column data to be viewed in 3D in real-time. Although the ability to map 3D targets in a wide swath around a survey vessel has obvious applications in terms of fisheries targets (and we are working with fisheries scientists to exploit these capabilities), it also allows careful identification of shallow hazards in the water column and may obviate the need for wire sweeps or diver examinations to verify least depths in hydrographic surveys. These water-column mapping tools were a key component to our efforts to map submerged oil and gas seeps and monitor the integrity of the Macondo 252 wellhead as part of the national response to the Deepwater Horizon oil spill. The Center's seep-mapping efforts continue to be of national and international interest as we begin to use them to help quantify the flux of methane into the ocean and atmosphere and expand them to provide details of subtle, but critical oceanographic phenomena. The initial water-column studies funded by this grant have led to many new opportunities including follow-up work that has been funded by the National Science Foundation, the Office of Naval Research, the Dept. of Energy, and the Sloan Foundation.

The tools and techniques that we had to quickly develop to find oil and gas in the water column during the Deepwater Horizon disaster have led to important spinoffs in the industrial sector. Again, citing Ed Saade's statement for the record to the House Transportation and Infrastructure Subcommittees:

*"More recently, the most significant ground-breaking technology discovery is based on the combination of MBES bathymetry, backscatter, and water column collection/detection applications. Initial applications were for a variety of reasons and disciplines, mostly scientific in nature as led by UNH CCOM JHC. These capabilities were quickly recognized by industry experts as new technologies with a variety of applications in the ocean mapping industry, including fisheries, aggregate materials surveys, various engineering design studies, and oil and gas exploration applications.*

*"An initial cost-benefit analysis of the impact in just the oil and gas exploration industry yields the following findings:*

- *Detection of Seabed Seeps of Hydrocarbons: During the past decade, the utilization of MBES for bathymetry, backscatter, and water column mapping has been directly applied to the detection, precise location, and analysis of seabed gas and oil seeps, mostly in deep water hydrocarbon basins and frontier areas. This scientific application of the methods discovered and perfected under the leadership of NOAA NOS OCS and the CCOM/JHC has been embraced and applied by companies and projects in the United States specifically to aide in the successful exploration and development of oil and gas reserves in water depths exceeding 10,000 feet. These studies provide a service to find seeps, evaluate the seeps chemistry, and determine if the seeps are associated with significant reservoir potential in the area of interest. This information is especially useful as a means to "de-risk" the wildcat well approach and ensure a greater possibility of success. It should be noted that many of the early terrestrial fields used oil seeps and geochemistry to help find the commercial payoffs. This was the original method of finding oil globally in the first half of the 20th century onshore and along the coastline. Estimates run into the millions of barrels (billions of dollars) of oil directly related to, and confirmed by, the modern MBES based seep hunting methodology.*
- *It is estimated that the current USA-based annual revenue directly related to operating this mapping technology is \$70 million per year. Note that this high level of activity continues today, despite the current extreme downturn in the offshore oil and gas industry. The seeps-related industry is expected to grow at an annualized rate of 25% per year. Globally, this value projects to be nearly double, or approximately \$130 million per year."*

Our ability to image targets in the water column has now gone beyond mapping fish and gas seeps. In the past few years, we have demonstrated the ability of both multibeam and broad-band single beam echo-sounders to image fine-scale oceanographic structure including thermohaline steps (an indicator of the process of mixing

between two water masses with different properties and an important mechanism of heat transfer in the ocean), internal waves, turbulence, and the depth of the mixed layer (the thermocline). Most recently, our water column imaging tools have been able to map the depth of the oxygen minimum in the Baltic Sea. This opening of a new world of “acoustic oceanography” with its ability to map ocean structure over long-distance from a vessel while underway has important ramifications for our ability to understand and model processes of heat transfer in the ocean as well as our understanding of the impact of the water column structure on seafloor mapping.

As technology evolves, the tools needed to process the data and the range of applications that the data can address will also change. We are now exploring Autonomous Surface Vehicles (ASVs) as platforms for hydrographic and other mapping surveys and are looking closely at the capabilities and limitations of Airborne Laser Bathymetry (lidar) and Satellite-Derived Bathymetry (SDB) in shallow-water coastal mapping applications. To further address the critical very-shallow-water regimes we are also looking at the use of small personal watercraft and aerial imagery as tools to measure bathymetry in that difficult zone between zero and ten meters water depth. The Center is also bringing together many of the tools and visualization techniques we have developed to explore what the “Chart of the Future” may look like.

The value of our visualization, water-column mapping, and Chart of the Future capabilities have also been demonstrated by our work with Stellwagen Bank National Marine Sanctuary aimed at facilitating an adaptive approach to reducing the risk of collisions between ships and endangered North American Right Whales in the sanctuary. We have developed 4D (space and time) visualization tools to monitor the underwater behavior of whales as well as to notify vessels of the presence of whales in the shipping lanes and to monitor and analyze vessel traffic patterns. Describing our interaction with this project, the director of the Office of National Marine Sanctuaries, said:

*“...I am taking this opportunity to thank you for the unsurpassed support and technical expertise that the University of New Hampshire’s Center for Coastal and Ocean Mapping/NOAA-UNH Joint Hydrographic Center provides NOAA’s Office of National Marine Sanctuaries. Our most recent collaboration to produce the innovative marine conservation tool WhaleAlert is a prime example of the important on-going relationship between our organizations. WhaleAlert is a software program that displays all mariner-relevant right whale conservation measures on NOAA nautical charts via iPad and iPhone devices. The North American right whale is one of the world’s most endangered large animals, and its protection is a major NOAA and ONMS responsibility. The creation of WhaleAlert is a major accomplishment as NOAA works to reduce the risk of collision between commercial ships and whales, a major cause of whale mortality.*”

*“...WhaleAlert brings ONMS and NOAA into the 21<sup>st</sup> century of marine conservation. Its development has only been possible because of the vision, technical expertise, and cooperative spirit that exists at CCOM/JHC and the synergies that such an atmosphere creates. CCOM/JHC represents the best of science and engineering, and I look forward to continuing our highly productive relationship.”*

Statements from senior NOAA managers and the actions of other hydrographic agencies and the industrial sector provide clear evidence that we are making a real contribution to NOAA, the nation, and the international community. We will certainly not stop there. CUBE, the Navigation Surface, GeoCoder, water column mapping, and the Chart of the Future offer frameworks upon which innovations are being built, and new efficiencies gained. Additionally, these achievements provide a starting point for the delivery of a range of hydrographic and non-hydrographic mapping products that set the scene for many future research efforts.

Since 2005, the Center has been funded through a series of competitively awarded Cooperative Agreements with NOAA. The most recent of these, which was the result of a national competition, funded the Center for the period of 1 January 2016 until December 2020. This document summarizes the highlights of this NOAA-funded effort during calendar year 2019; detailed progress reports for each of the individual grants can be found at our website <http://ccom.unh.edu/reports>.



## Highlights from Our 2019 Program

Our efforts in 2019 represent the fourth year of our work in response to a Federal Funding Opportunity (FFO) that defined four programmatic priorities:

### Innovate Hydrography

#### Transform Charting and Change Navigation

#### Explore and Map the Continental Shelf

#### Develop and Advance Hydrographic and Nautical Charting Expertise

Under these, 14 specific research requirements were prescribed (our short name for each research requirement follows the description, highlighted in bold):

### Innovate Hydrography

1. Improvement in the effectiveness, efficiency, and data quality of acoustic and lidar bathymetry systems, their associated vertical and horizontal positioning and orientation systems, and other sensor technology for hydrographic surveying and ocean and coastal mapping, including autonomous data acquisition systems and technology for unmanned vehicles, vessels of opportunity, and trusted partner organizations. **Data Collection**
2. Improvement in technology and methods for more efficient data processing, quality control, and quality assurance, including the determination and application of measurement uncertainty, of hydrographic and ocean and coastal mapping sensor and ancillary sensor data, and data supporting the identification and mapping of fixed and transient features of the seafloor and in the water column. **Data Processing**
3. Adaptation and improvement of hydrographic survey and ocean mapping technologies for improved coastal resilience and the location, characterization, and management of critical marine habitat and coastal and continental shelf marine resources. **Tools for Seafloor Characterization, Habitat, and Resources**
4. Development of improved tools and processes for assessment and efficient application to nautical charts and other hydrographic and ocean and coastal mapping products of data from both authoritative and non-traditional sources. **Third Party and Non-traditional Data**

### Transform Charting and Change Navigation

1. Development of improved methods for managing hydrographic data and transforming hydrographic data and data in enterprise GIS databases to electronic navigational charts and other operational navigation products. New approaches for the application of GIS and spatial data technology to hydrographic, ocean, and coastal mapping, and nautical charting processes and products. **Chart Adequacy and Computer-Assisted Cartography**
2. Development of innovative approaches and concepts for electronic navigation charts and for other tools and techniques supporting marine navigation situational awareness, such as prototypes that are real-time and predictive, are comprehensive of all navigation information (e.g., charts, bathymetry, models, currents, wind, vessel traffic, etc.), and support the decision process (e.g., under-keel clearance management). **Comprehensive Charts and Decision Aids**
3. Improvement in the visualization, presentation, and display of hydrographic and ocean and coastal mapping data, including four-dimensional high-resolution visualization, real-time display of mapping data, and mapping and charting products for marine navigation as well as coastal and ocean resource management and coastal resilience. **Visualization**

## Explore and Map the Continental Shelf

1. Advancements in planning, acquisition, understanding, and interpretation of continental shelf, slope, and rise seafloor mapping data, particularly for the purpose of delimiting the U.S. Extended Continental Shelf. **Extended Continental Shelf**
2. Development of new technologies and approaches for integrated ocean and coastal mapping, including technology for creating new products for non-traditional applications and uses of ocean and coastal mapping. **Ocean Exploration Technologies and IOCM**
3. Improvements in technology for integration of ocean mapping with other deep ocean and littoral zone technologies such as remotely operated vehicles and telepresence-enhanced exploration missions at sea. **Telepresence and ROVs**

## Develop and Advance Hydrographic and Nautical Charting Expertise

1. Development, maintenance, and delivery of advanced curricula and short courses in hydrographic and ocean mapping science and engineering at the graduate education level—leveraging to the maximum extent the proposed research program, and interacting with national and international professional bodies—to bring the latest innovations and standards into the graduate educational experience for both full-time education and continuing professional development. **Education**
2. Development, evaluation, and dissemination of improved models and visualizations for describing and delineating the propagation and levels of sound from acoustic devices including echo sounders, and for modeling the exposure of marine animals to propagated echo sounder energy. **Acoustic Propagation and Marine Mammals**
3. Effective delivery of research and development results through scientific and technical journals and forums and transition of research and development results to an operational status through direct and indirect mechanisms including partnerships with public and private entities. **Publications and R2O**
4. Public education and outreach to convey the aims and enhance the application of hydrography, nautical charting, and ocean and coastal mapping to safe and efficient marine navigation and coastal resilience. **Outreach**

To address the four programmatic priorities and 14 research requirements, the Center divided the research requirements into themes and sub-themes and responded with 60 individual research tasks, each with an identified investigator or group of investigators as the lead. As our research progresses and evolves, the boundaries between the themes, programmatic priorities, research requirements, and tasks, sometimes become blurred. For example, from an initial focus on sonar sensors, we have expanded our efforts to include lidar and satellite imagery. Our data-processing tools are finding application in habitat characterization, mid-water mapping, and IOCM efforts. The data-fusion and visualization projects are also blending with our seafloor characterization, habitat, and Chart of the Future efforts as we begin to define new sets of “non-traditional” products. This blending is a natural (and desirable) evolution that slowly evolves the nature of the programs and the details of our efforts. This evolution is constantly being reviewed by Center management and the Program Manager, and tasks are adjusted as they are completed, merged, or are modified due to changes in personnel (e.g., the loss of Shachak Pe’eri from the Center faculty when he became a NOAA employee and moved to Silver Spring, or the loss of David Mosher due to his election to the Committee on the Limits of the Continental Shelf). This process is essential to allow innovation to flourish under the cooperative agreement.

As we complete the fourth year of effort, the updated tasks are presented in Figure ES-1. Note that when tasks are closed out, merged or completed, we have chosen not to renumber the other tasks so that there is continuity of reporting throughout the duration of the grant.

This executive summary offers only an overview of some of the Center's 2019 efforts through the presentation of a subset of ongoing tasks within the context of the four major programmatic priorities; the complete progress report with descriptions of all efforts and the Center's facilities can be found at <http://ccom.unh.edu/reports>.

							2019	
PROGRAMMATIC PRIORITIES	RESEARCH REQUIREMENTS	THEMES	SUB-THEMES	PROJECTS	POC	REF. #	TRL	
INNOVATE HYDROGRAPHY	DATA COLLECTION	SENSOR CALIBRATION AND SONAR DESIGN	SONAR	Tank Calibrations	Lanzoni	1	3	
				PMBS Evaluation	Schmidt	2	4	
				Circular Array Bathymetric Sonar	Weber	3	3	
			LIDAR	Synthetic Aperture Sonar	Weber and Lyons	4	2	
				Lidar Simulator	Eren	5	3	
				SOUND SPEED	Distributed Temperature Sensing	Eren	6	X
		SENSOR INTEGRATION and REAL-TIME QA/QC	Deterministic Error Analysis/Integration Error	Hughes Clarke	7	4		
			Data Performance Monitoring	Calder	8	3		
			Auto Patch Test Tools	Calder	9	2		
			INNOVATIVE PLATFORMS	AUVs	Nav Processing and Boot Camp	Schmidt	10	3
				ASVs	Add-on Sensors and Hydro Applications	Schmidt	11	2
				TRUSTED PARTNER DATA	Trusted Hardware	Calder	12	4
	DATA PROCESSING	ALGORITHMS and PROCESSING	CHRT and Expanded Processing Methods	Calder	13	5		
			Multi-Detect Processing	Weber and Calder	14	5		
			Data Quality and Survey Validation Tools	Calder	15	4		
			Phase Measuring Bathymetric Sonar Processing	Schmidt	16	2		
			Automatic Processing for Topo-Bathymetric LIDAR	Calder	17	4		
			Hydro-significant Object Detection	Calder and Masetti	18	4		
	FIXED AND TRANSIENT WATERCOLUMN AND	SEAFLOOR	Watercolumn Target Detection	Weber	19	6		
		WATER COLUMN	Mapping Gas and Leaky Pipelines in Watercolumn	Weber	20	7		
	SEAFLOOR CHARACTERIZATION, HABITAT and RESOURCES	COASTAL AND CONTINENTAL SHELF RESOURCES	Tools for Identification of Marine Mineral Deposits	Ward	21	2		
			SONAR	GeoCoder/ARA	Masetti	22	4	
				Singlebeam Characterization	Lippmann	23	1	
				Multi-frequency Seafloor Backscatter	Hughes Clarke and Weber	24	4	
				Lidar Waveform Extraction	Parrish	25	2	
				Object Based Image Analysis	J. Dijkstra	26	X	
		Video Mosaics and Segmentation Techniques		Rzhanov	27	5		
		SEAFLOOR CHARACTERIZATION	CRITICAL MARINE HABITAT	Margin-wide Habitat Analysis	Mayer and J.Dijkstra	28	1	
				Shoreline Change	Eren	29	2	
				Seabed Change	Hughes Clarke	30	2	
			COASTAL RESILIENCE and CHANGE DETECTION	Change in Benthic Habitat and Restoration	J. Dijkstra	31	7	
				Marine Coastal Decision Support Tools	Butkiewicz and Vis Lab	32	2	
				Temporal Stability of the Seafloor	Lippmann	33	2	
		THIRD PARTY and NON-TRADITIONAL DATA	THIRD PARTY DATA	Assessment of Quality of 3rd Party Data	Calder	34	3	
				Assessment of ALB data	Eren	35	1	
				Development of Techniques for Satellite Derived Bathymetry	Eren	36	X	
NON-TRADITIONAL DATA SOURCES			ALB					
			SDB					
TRANSFORM CHARTING AND NAVIGATION	CHART ADEQUACY and COMPUTER-ASSISTED CARTOGRAPHY			Managing Hydrographic Data and Automated Cartography	Calder and Kastrisios	37	3	
				Chart Adequacy and Re-survey Priorities	Calder, Kastrisios, and Masetti	38	3	
				Hydrographic Data Manipulation Interfaces	Calder, Hughes Clarke, Butkiewicz, and Ware	39	4	
	COMPREHENSIVE CHARTS AND DECISION AIDS	INFORMATION SUPPORTING SITUATIONAL AWARENESS	Currents Waves and Weather	Ware, Sullivan, and Vis. Lab.	40	4		
			Under-keel Clearance, Real-time and Predictive Decision Aids	Calder and Vis. Lab.	41	3		
		CHARTS and DECISION AIDS	Ocean Flow Model Distribution and Accessibility	Sullivan	42	7		
			Textual Nautical Information	Sullivan	43	7		
	VISUALIZATION AND RESOURCE MANAGEMENT	GENERAL ENHANCEMENT OF VISUALIZATION		Augmented Reality Supporting Charting and Nav	Butkiewicz	44	4	
		Tools for Visualizing Complex Ocean Data	Ware, Sullivan, and Vis. Lab.	45	4			
EXPLORE AND MAP THE EXTENDED CONTINENTAL SHELF	EXTENDED CONTINENTAL SHELF			Lead in Planning, Acquiring and Processing ECS	Gardner and Mayer	47	8	
				Extended Continental Shelf Taskforce	Gardner and Mayer	48	8	
				Best Approaches for Legacy Data: Delineation Techniques	Gardner and Mayer	49	5	
	OCEAN EXPLORATION			ECS Data for Ecosystem Management	Mayer and J. Dijkstra	50	3	
				Potential of MBES Data to Resolve Oceanographic Features	Weber, Mayer, and Hughes Clarke	51	2	
	TELEPRESENCE AND ROVS			Immersive Live Views from ROV Feeds	Ware	52	2	
HYDROGRAPHIC EXPERTISE	EDUCATION			Revisit Education Program	Hughes Clarke, Kastrisios and S. Dijkstra	53	N/A	
	ACOUSTIC PROPAGATION AND MARINE MAMMALS			Modelling Radiation Patterns of MBES	Weber and Lurton	54	6	
				Web-based Tools for MBES Propagation	Johnson and Arsenault	55	2	
	PUBLICATIONS AND R2O OUTREACH			Impact of Sonars on Marine Mammals	Miksis-Olds	56	3	
				Continue Publication and R2O Transitions	Mayer	57	N/A	
				Expand Outreach and STEM Activities	Hicks-Johnson and Mitchell	58	N/A	
DATA MANAGEMENT	EXTENDED DATA MANAGEMENT PRACTICE			Data Sharing, ISO19115 Metadata	Johnson	59	4	
				Enhanced Web Services for Data Management	Johnson	60	6	

Figure ES-1. Current breakdown of Programmatic Priorities and Research Requirements of FFO into individual projects or tasks.



# Programmatic Priority 1: Innovate Hydrography

## Data Collection

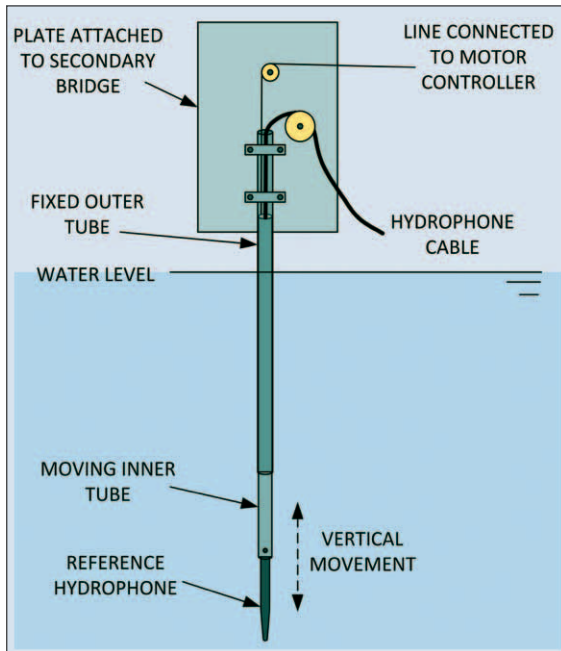

Figure ES-2. Vertical position control of reference hydrophone.

### State-of-the-Art Sonar Calibration Facility

We continue to work closely with NOAA and the manufacturers of sonar and lidar systems to better understand and calibrate the behavior of the sensors used to make the hydrographic and other measurements used for ocean mapping. Many of these take advantage of our unique acoustic test tank facility. The largest of its kind in New England, it is equipped

with state-of-the-art test and calibration facilities. Upgrades to the facility include continuous monitoring of temperature and sound speed, a computer-controlled standard-target positioning system (z-direction; Figure ES-2), and the capability for performing automated 2D beam-pattern measurements. The facility is regularly used by Center researchers for now-routine measurements of beam pattern, driving-point impedance, transmitting voltage response (TVR), and receive sensitivity (RS).

Among the systems calibrated this year were Reson T50-P and Simrad ES70, ES120 and ES200 sonars. Standard tank calibration procedures and our newly developed (and much less time consuming) extended target method were compared and evaluated for the T50-P. After calibration, the T50-P was brought to our “NEWBEX” offshore backscatter reference line to compare the efficacy of in-tank calibrations to field calibrations (Figure ES-3).

### Synthetic Aperture Sonar

Leveraging efforts supported by the Office of Naval Research, Tony Lyons is looking into the applicability of synthetic aperture sonar for automatic object identification, seafloor characterization, and understanding oceanographic conditions. This year, Lyons took part in technical evaluations of the Kraken KAT-FISH SAS system on board the NOAA Ship *Okeanos Explorer* (Figure ES-4). An advantage of SAS system is the very high resolution achievable over a 320 m

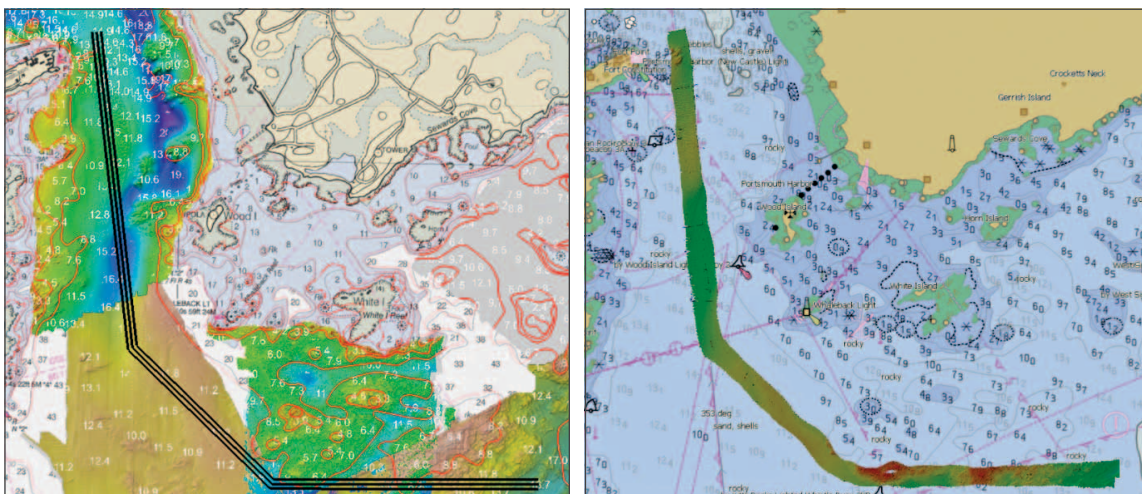

Figure ES-3. Left: Line plan for the 2019 NEWBEX project. Lines have been overlain on top of existing high-resolution bathymetry for the region. Right: Collected bathymetry at 300 kHz.

swath (160 m on each side for the Kraken). The KATFISH can be run at faster speeds than an AUV-mounted SAS system owing to its long receive array (180 cm). Lines were regularly run at 6 knots during the technology demonstration and images were produced with tow speeds as fast as 8 knots.

### Use of Autonomous Surface Vessels for Hydrography

In our efforts to explore approaches to increasing operational survey efficiency and the quality of hydrographic survey data, the Center has embarked on a major research effort focused on evaluating the promise of autonomous surface vehicles (ASVs) for seafloor survey, and to add capability and practical functionality to these vehicles with respect to hydrographic applications. In support of this effort, the Center has acquired, through purchase, donation, or loan, several ASVs. The Bathymetric Explorer and Navigator (BEN) a C-Worker 4 model vehicle, was the result of collaborative design efforts between the Center and ASV Global

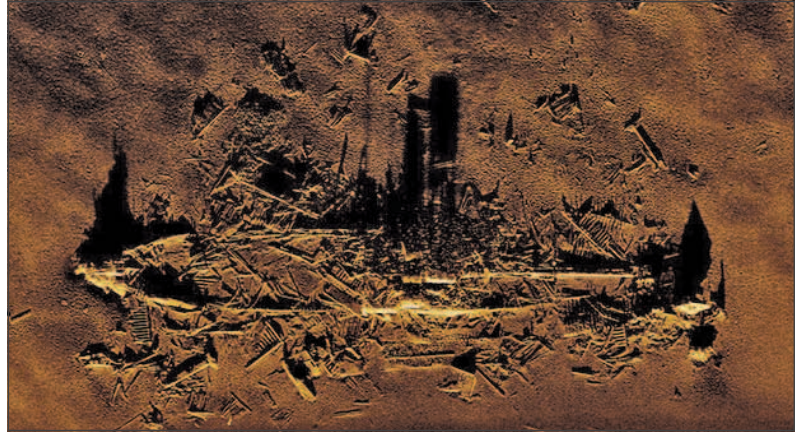

Figure ES-4. Synthetic aperture sonar image collected over a shipwreck site off Virginia using the KATFISH towed SAS system.

LLC beginning in 2015. BEN was delivered in 2016. Teledyne Oceansciences donated a Z-boat ASV to the Center by in 2016, and Seafloor Systems donated an Echoboat in early 2018. A Hydronaulix EMILY boat, donated by NOAA, is in the process of a refit and, most recently—through the Center’s industrial partnership program—the Center has acquired access to a new iXblue DriX ASV (Figure ES-5).



ASV Global W-4  
Bathymetric Explorer and Navigator - BEN



Seafloor Systems Echoboat



Hydronaulix EMILY Boat



iXblue DriX



Teledyne Oceansciences Z-Boat

Figure ES-5. The Center’s fleet of Autonomous Surface Vessels.



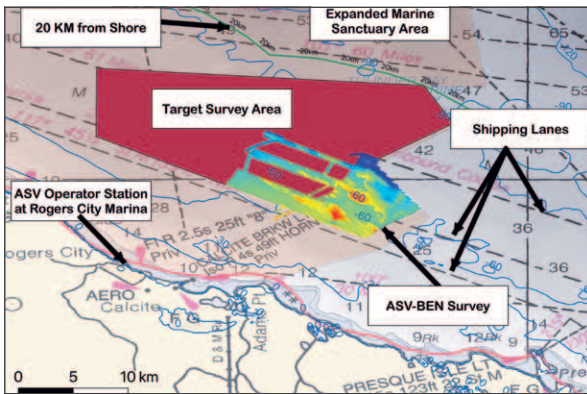

Figure ES-6. From Top: The ASV Shore Command Center, mapping data collected in Lake Huron, operating ASV-BEN in Lake Huron during the Thunder Bay expedition, and test of telemetry range of broadband radio (here at 20 km range).

These various vehicles provide platforms for in- and off-shore seafloor survey work, product test and evaluation for these industrial partners, and ready vehicles for new algorithm and sensor development at the Center. BEN is an off-shore-capable vessel, powered by a 30 h.p. diesel jet drive, is 4 m in length, has a 20-hour endurance at 5.5 knots, and a 1 kW electrical payload capacity. The Z-boat, Echoboat, and EMILY vehicles are coastal or in-shore, two-man portable, battery-powered systems with endurances of 3-6 hours at a nominal 3 knots (sensor electrical payload dependent). The DriX is an ocean-capable vessel, with a unique carbon fiber hull, giving it a maximum speed exceeding 13 knots and endurance exceeding five days at 8 knots.

ASV operations in 2019 focused on collaborative expeditions using BEN with the Ocean Exploration Trust and the National Marine Sanctuaries Program and testing of the DriX and sea trials on the NOAA Ship *Thomas Jefferson*. Expeditions were undertaken to Thunder Bay National Marine Sanctuary (May), American Samoan National Marine Sanctuary (July–August), and in the vicinity of Nikumaroro Island (August). Intensive testing of the DriX took place in September and October. Details of these events and the ongoing research and engineering involved are provided in the full progress report.

Operations at Thunder Bay National Marine Sanctuary featured the first use of a shore-based command center (Figure ES-6, top) equipped with an antenna mast system, AIS, long-range Marine Broadband radio, and a PZT camera with 30x zoom that could automatically track the vehicle. The radio was able to communicate to a maximum of 24 km with typical ranges on the order of 15 km (Figure ES-6, bottom). As part of the trials, numerous hardware and software upgrades were made to the ASV including path following algorithms, sonar upgrades, and the installation of a new lidar to support situational awareness. Research continues into the development of a real-time neural network for the automatic identification and classification of targets (based on cameras, lidar, radar, and other available sensors).

In support of the American Samoa National Marine Sanctuary, the ASV surveyed Pago Pago Harbor and Aunu'u Island, then proceeded to survey around Nikumaroro Island in support of the Ocean Exploration Trust's work (Figure ES-7). During these operations, the Center also developed approaches for using aerial drone imagery to fill the survey gap beyond the surf break.



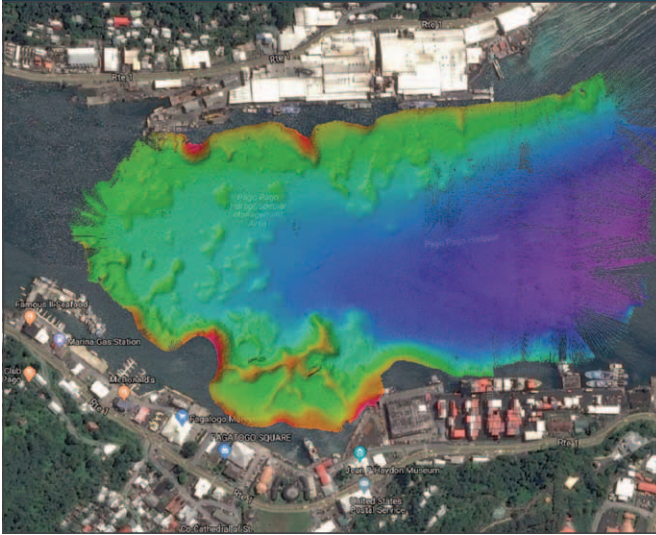
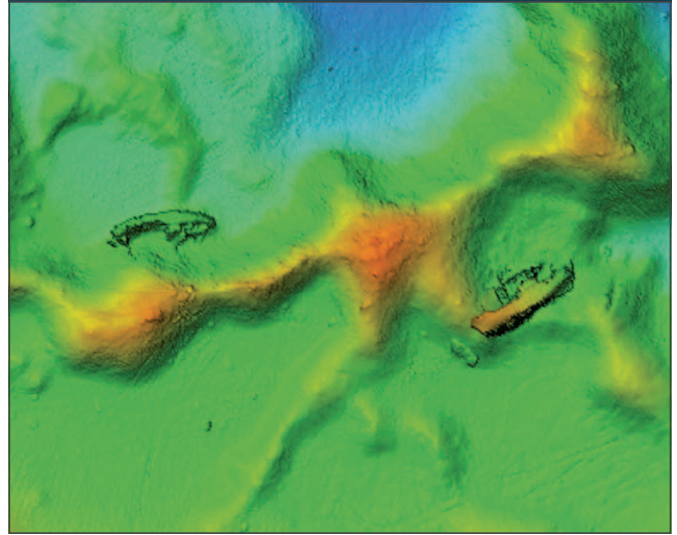

Figure ES-7. ASV Survey highlights from Pago Pago Harbor, American Samoa.



In the autumn and winter of 2019, Val Schmidt and the ASV team devoted their efforts to working with industrial partner iXBlue to ready their DriX ASV for NOAA field trials. The DriX is unique for an ASV since it can match or even exceed the survey speeds of a large ship with equivalent data quality and multi-day endurance.

In October, the Center facilitated DriX trials aboard the NOAA Ship *Thomas Jefferson*. Efforts focused on adapting of the ship's davit to accept the DriX and the Delivery System (DDS), establishing an ASV operations center aboard the ship, and several days of testing and developing recovery methods for vari-

ous failures at sea (Figure ES-8). Integration paths of DriX-collected data were established with the ship's acquisition systems, and operational survey models were evaluated. The Center provided draft handling and deployment procedures for the ship and an operational guideline for DriX operations for NOAA ships for future operations.

#### Deterministic Error Analysis and Data Performance Monitoring

Included in the broad category of "Data Collection" is our research into the causes—at acquisition—of many of the artifacts that degrade the data that we



Figure ES-8. Trials of the DriX ASV aboard the NOAA Ship *Thomas Jefferson*.

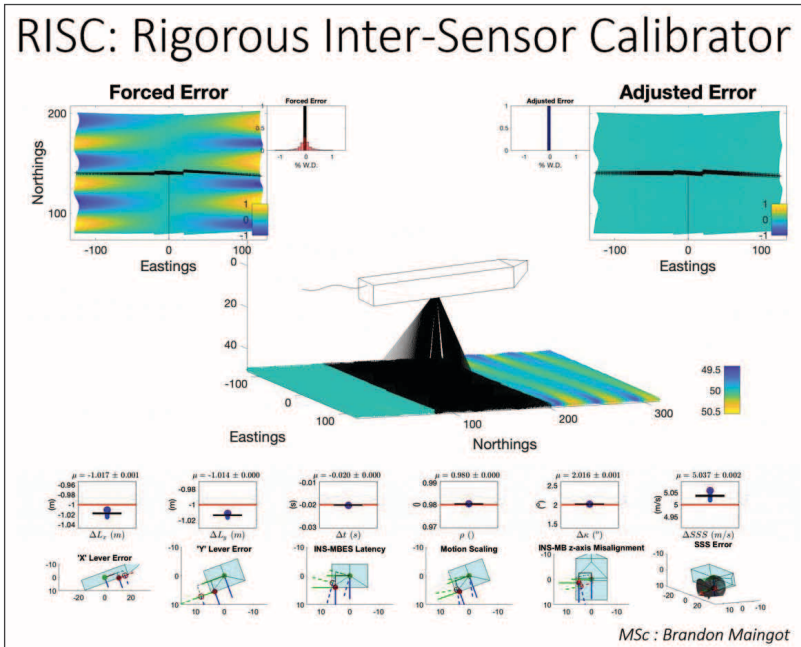

Figure ES-9. Input wobbled seafloor (top-left), the selection of the swath corridor (center), the resulting local and asymptotic estimation of the six integration errors (bottom), and finally the resulting de-wobbled surface (top right).

collect, and the development of a suite of tools to help recognize and hopefully mitigate these problems. With the ever-improving accuracy of the component sensors in an integrated multibeam system, the resultant residual errors have come to be dominated by the integration rather than the sensors themselves. Identifying the driving factors behind the residual errors (known as wobbles) requires an understanding of the way they become manifest. In this reporting period, modeling tools were developed to better undertake wobble analysis, focusing on the following areas:

**Improved Wobble Extraction**

To address these and other “wobble” issues, John Hughes Clarke and graduate student Brandon Maingot are developing improved methods for extracting the motion-derived depth residuals in a dataset. Maingot has developed a full simulator for a multi-sector sonar acquiring data under controlled dynamic conditions that collects bottom tracking information over undulating seafloor topography. The acquired data is then deliberately re-integrated using erroneous parameters to create a “wobbled”

seafloor. This then provides the input, equivalent to a real system, in which the errors are perfectly known so that an approach can be developed and tested to see how close to the truth an inversion estimate will get.

The challenge of any field analysis tool is predicting how the data should look in the absence of the integration problem. To do that, an estimate of the seafloor “truth” must be established. Maingot’s approach follows earlier methods in assuming that the underlying seafloor does not have short wavelength roughness with a length scale corresponding to the projected motion. This is done by fitting a quadratic surface to a short section of the swath corridor. Using that surface “truth,” the mismatch of each of the soundings to that quadratic estimate is used as the input into a least squares minimization approach (Figure ES-9).

This is termed the Rigorous Inter-Sensor Calibrator (RISC). Short period coherent undulations in bottom tracking remain one of the prime concerns in OCS hydrographic data quality control. With the widespread adoption of multi-sector systems by the

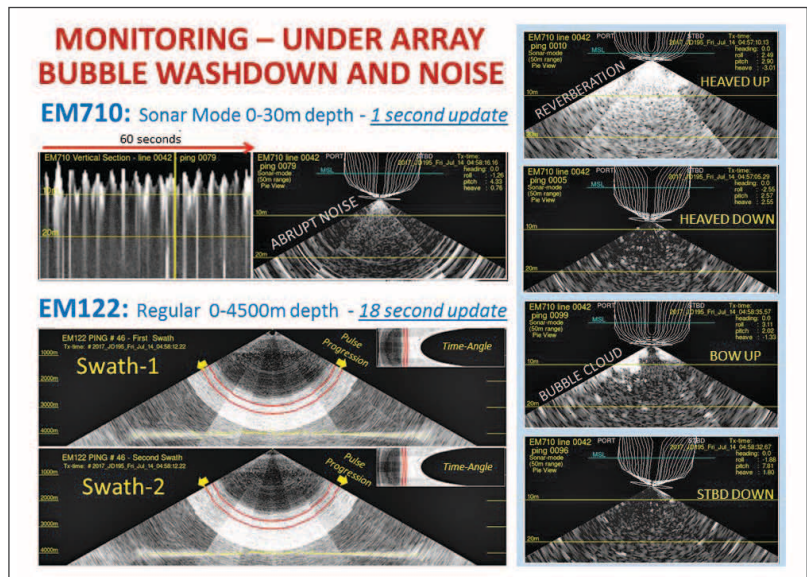

Figure ES-10. Simultaneous monitoring of near-array scattering and its effect on multi-sector deep water multibeam performance. Top-left shows a 60-second curtain of volume scattering within 30 m of the surface, together with instantaneous across track view of the scattering field. Bottom-left shows an 18-second ping cycle of an EM122, highlighting the one-second period during which the near array image above was collected. On the right are stills from an animation showing the second-by-second evolution of the scattering field immediately under the hull during a single EM122 ping cycle.



OCS fleet, there is a pressing need for operational tools that can automatically assess integration errors.

**Bubble Washdown**

Even with perfect integration of motion, if there are periodic external noise and sound blockage events due to bubbles close to the transducers generated by wave activity, this will overprint onto the data. Hughes Clarke has been investigating this issue by using a shallow water multibeam sonar set to “sonar mode” to image the volume scattering field within a few 10s to 100s of meters below the hull and allow the visualization of near surface bubble clouds (Figure ES-10). With the gradual revitalization of the NOAA fleet, the ability to monitor the second-by-second performance of the under-hull environment will aid in the design and placement of transducers as well as provide a monitoring tool to help in operational survey decisions.

**Sound Speed Manager (HydrOffice)**

We continue to focus on developing a suite of tools to monitor data in real-time, or to provide better support for data collection and quality monitoring. Our goal is to significantly reduce the time and effort needed for downstream processing, or to at least provide better assurance that no potentially problematic issues exist in the data before the survey vessel leaves the area. A major component of this effort is the building of tools in collaboration with NOAA’s Hydrographic Systems Technology Branch (HSTB) so that they can be directly implemented by NOAA’s field programs through the HydrOffice tool kit, and NOAA Pydro. Included in this tool kit is the Sound Speed Manager, a merger of a previous Center tool and NOAA’s “Velocipy” tool. Sound Speed Manager manages sound speed profiles and greatly simplifies their processing and storage. This year, we saw numerous improvements to the user interface, systems supported, database capabilities and other functionalities, including interfacing with the new

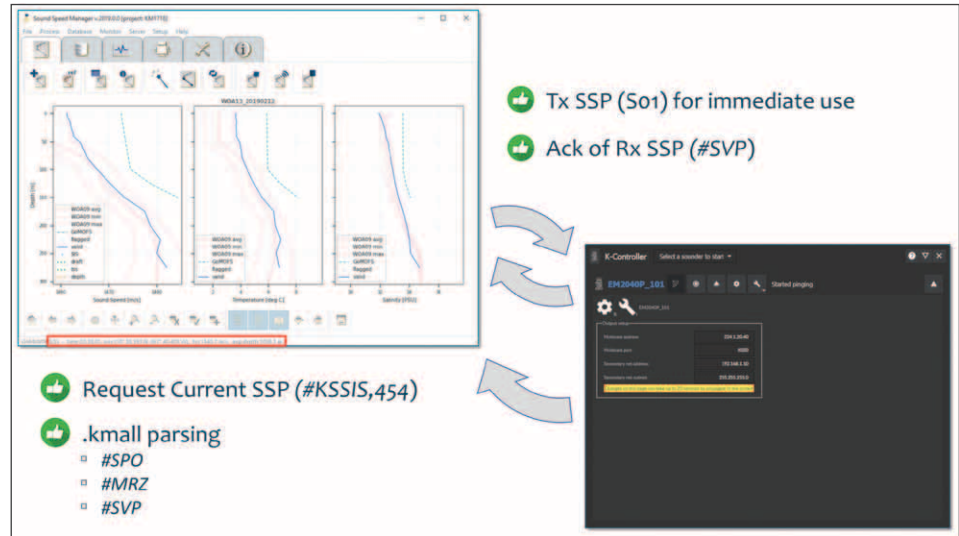

Figure ES-11. Summary of the current interactions for the experimental support of the Kongsberg K-Controller. SSM is able to transmit the enhanced sound speed profile data to K-Controller for immediate use, check its reception, retrieve the current profile, and parse the information-rich .kmall datagrams broadcast through UDP protocol packets.

Kongsberg K-Controller and .kmall data format (Figure ES-11). Sound Speed Manager is now in wide use across NOAA, UNOLS, and other hydrographic agencies and scientific institutions (Figure ES-12). It has also been distributed through the U.S. University-National Oceanographic Laboratory System (UNOLS) fleet by Paul Johnson and Kevin Jerram, acting on behalf of the National Science Foundation (NSF)-funded Multibeam Advisory Committee (MAC).

**SmartMap (HydrOffice)**

Spatial and temporal variability in sound speed is often the single largest contributor to errors in hydrographic surveys. In order to help users better understand the sound speed variability in the area they will be, or are working in, Center researchers have been developing The Sea Mapper’s Acoustic Ray Tracing Monitor and Planning (SmartMap) tool to provide a means to evaluate the impact of oceanographic temporal and spatial variability on hydrographic

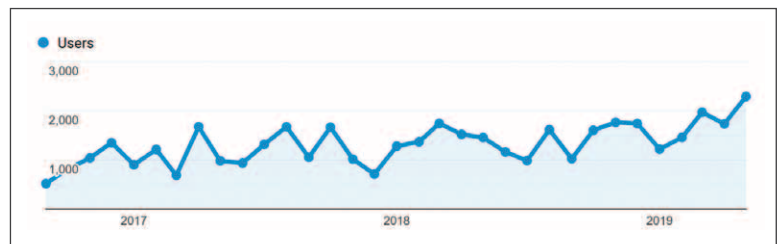

Figure ES-12. Accesses of HydrOffice online resources. The number of unique users has been steadily increasing since its initial launch in 2016.

surveys. The tool highlights areas where particularly high or low variability in the sound speed is expected, allowing the surveyor to assess how often to take profiles, where to take them, or even (in extreme circumstances) conclude that there is no rate at which SSPs can practicably be taken that will capture the variability of an area (with the implication that surveying at a different time is the more appropriate solution). Predictions used to be made based on the Global Real-time Operational Forecast System (RTOFS), and the World Ocean Atlas 2013 for climatology; this past year, experimental prediction products based on the Gulf of Maine Operational Forecast System (GoMOFS) data were added as alternatives (Figure ES-13). Such products provide better spatio-temporal coverage, and the evaluation of the potential application of high-resolution models to hydrographic problems has recently started. We also started the development of “ForeCast,” an algorithm that uses the predicted spatio-temporal

variability provided by an oceanographic forecast modeling system to inform the user when and where sound speed casts are required to maintain a certain level of uncertainty in the bathymetric data.

### Trusted Community Bathymetry

Finally, under the rubric of Data Collection, we include efforts to evaluate the usefulness of crowd sourced, volunteered, or, more appropriately, trusted community bathymetry. Recognizing the reticence of many hydrographic agencies to ingest into the charting process data from uncontrolled sources, we are exploring a system where the data from a volunteer—or at least non-professional—observer is captured using a system that provides sufficient auxiliary information to ensure that the data does meet the requirements of a hydrographic office. That is, instead of trusting to the “wisdom of the crowd” for data quality, attempting to wring out valid data from uncontrolled observations, or trying to establish a

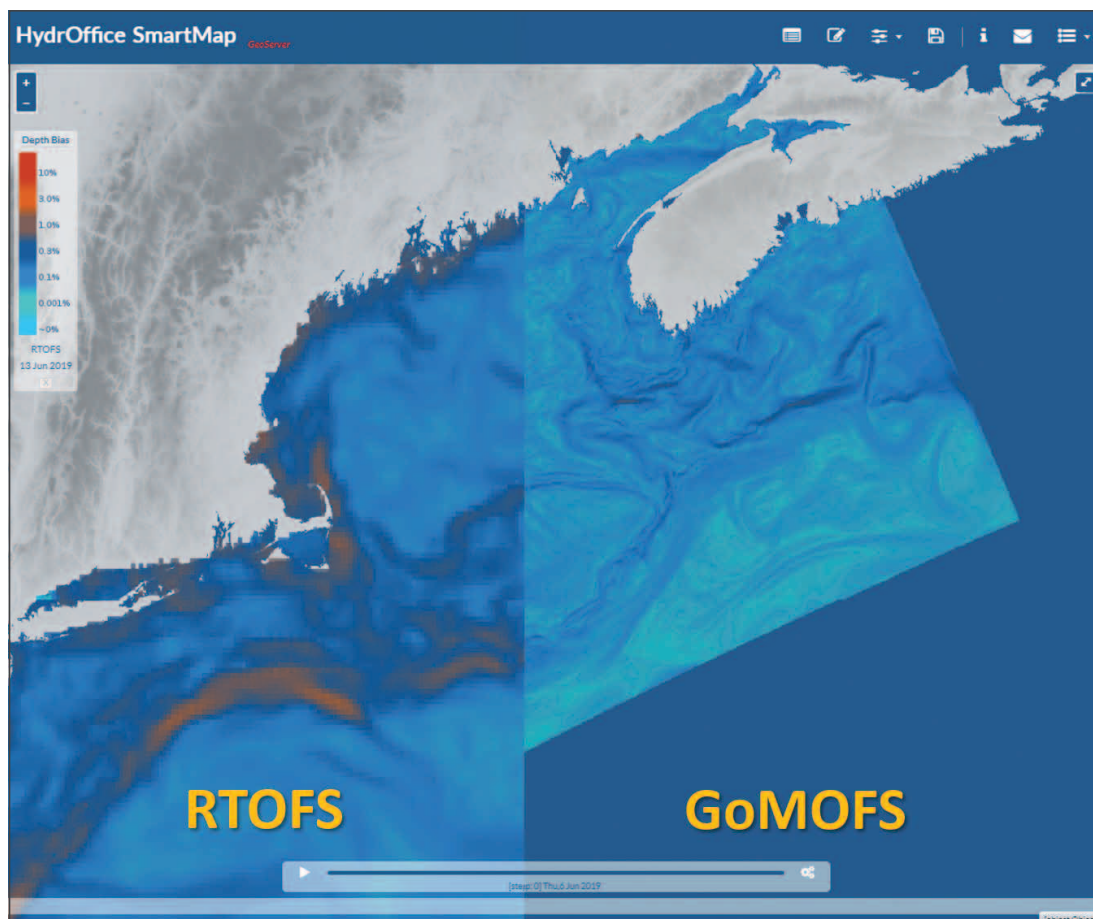

Figure ES-13. Comparison of the spatial resolution between the GoMOFS predictions (on the right) and the Global RTOFS one (on the left).



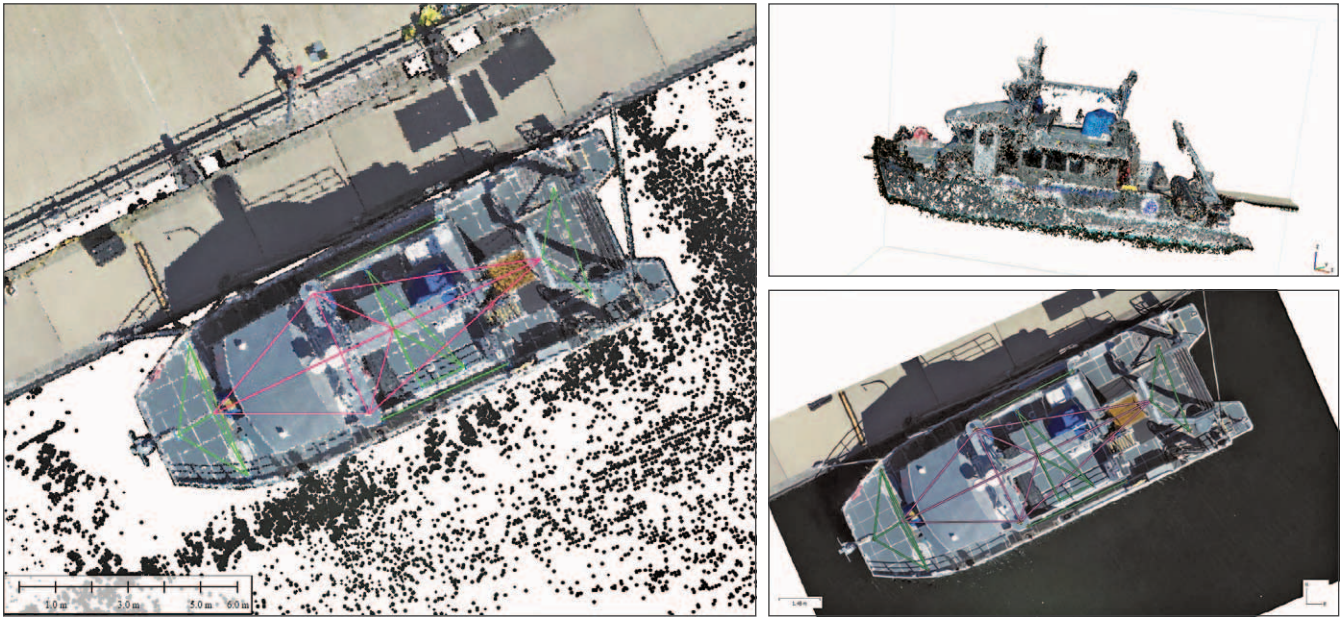

Figure ES-14. Left: Point cloud for the R/V *Gulf Surveyor* constructed using aerial LiDAR from a DJI Matrice UAV at multiple altitudes. Note the lines joining survey monuments (purple) and Secchi targets (green), which are measured in the point cloud to assess the technique. Upper-right: Point cloud created using Structure from Motion (SfM) techniques from drone photogrammetry. Lower-right: Orthomosaic of the R/V *Gulf Surveyor* corresponding to the point cloud on left. Note the lines joining survey monuments (purple) and Secchi targets (green), which are measured in the orthomosaic to assess the technique.

trusted observer qualification, we consider the question, "what if the observing system was the trusted component?"

Brian Calder, Semme Dijkstra, and Dan Tauriello have been collaborating with Kenneth Himschoot and Andrew Schofield (SeaID) on the development of such a Trusted Community Bathymetry (TCB) system, including hardware, firmware, software, and processing techniques. The aim is to develop a hardware system that can interface with the navigational echosounder of a volunteer ship as a source of depth information, while capturing sufficient GNSS information to allow it to establish depth to the ellipsoid and auto-calibrate for offsets, with sufficiently low uncertainty that the depths generated can be qualified for use in charting applications. Originally, the proposed plan for this task was to develop such a system independently; but collaborating with SeaID, who already produce data loggers of this type and strongly interact with the International Hydrographic Organization's Crowd-sourced Bathymetry Working Group, is a more efficient route to the same objective.

Testing of the development system during the last reporting period demonstrated that the prototype system can resolve soundings with respect to the

ellipsoid with uncertainties on the order of 15-30 cm (95%), well within IHO S.44 Order 1 total vertical uncertainty (TVU) for the depth considered. In this reporting period, work focused on testing the prototype with a new, cheaper antenna made by Harxon Corporation, which is the intended "production" antenna for the system (being significantly cheaper), while research focused on extensions of the system for auxiliary sensors and observer ship horizontal offset calibration. Included in this effort is the development of demonstrator system and concept of operations for the use of low-cost recreational sidescan sonar for Trusted Community Bathymetry and efforts to find ways to quickly find the horizontal offsets between a vessel's GNSS antenna and the ship's echosounder (critical to providing accurate bathymetry from a Trusted Community Bathymetric system). To address this last topic, Calder and graduate student Casey O'Heran have been experimenting with the use of photogrammetry and lidar from aerial drones to produce these offsets (Figure ES-14), achieving centimetric errors against ground-truth offset estimates. Such techniques may provide a quick and inexpensive means to determine horizontal offsets on any vessel to the level of accuracy needed to produce qualified bathymetric data.

## Data Processing: Bathymetry - Sonar

### Next Generation Automated Processing Approaches – CHRT

In concert with our efforts to better understand the behavior and limitations of the sensors we use to collect hydrographic data, we are also developing a suite of processing tools aimed at improving the efficiency of producing the end-products we desire and, just important, at quantifying the uncertainty associated with the measurements we make. These efforts, led by Brian Calder, are now directed to further development of the next generation of the CUBE approach to bathymetric data processing—an algorithm called CHRT (CUBE with Hierarchical Resolution Techniques). The CHRT algorithm was developed to provide support for data-adaptive, variable resolution gridded output. This technique allows the estimation resolution to change within the area of interest, and the estimator to match the data density available. The technology also provides for large-scale estimation, simplification of the required user parameters, and a more robust testing environment, while still retaining the core estimation technology from the previously-verified CUBE algorithm. CHRT is being developed in conjunction with the Center's Industrial Partners who are pursuing commercial implementations.

Although the core CHRT algorithm is complete in principle and has been licensed to Center Industrial Partners for implementation, modifications—some

significant—continue to be made as the research progresses. In the current reporting period, we assisted a number of Industrial Partners with parameter configurations, and provided tools to assist with survey edge effects to NOAA for implementation in HydrOffice/Pydro.

One key to many NOAA hydrographic activities (and data specifications) is an accurate estimate of the density of data collected in a given area. An evolution in CHRT is the implementation of a “level of aggregation” algorithm to estimate data resolution. In the original implementation, data density was estimated by computing the area insonified by the sounder over a coarse resolution grid, the cells of which were then piecewise replaced with higher resolution grids over which the final depth estimation was computed. This approach is appropriate for swath-based data but is not well-suited to single-beam, mixed data sets, or most lidar data. To address this issue, Calder has now implemented a fine-to-coarse approach, estimating the level at which high-resolution cells need to be aggregated in order to ensure that the data density is enough to reliably estimate depth. This “level of aggregation” approach works with all data types, is computationally efficient, and has the added benefit of directly addressing the critical question of survey “completeness” (Figure ES-15).

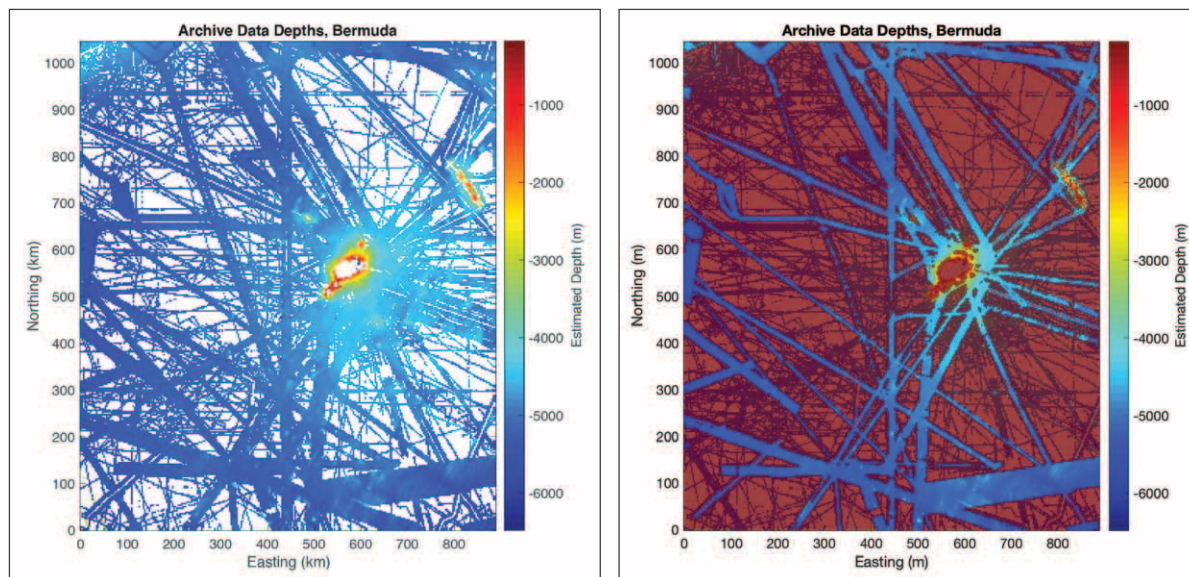

Figure ES-15. Estimated depth (a) and “complete” coverage (b). Depth is the primary low-resolution CHRT estimate from raw observations at 3,125 m cell resolution; areas with semi-transparent red tint are considered “incomplete” given the assumptions of five observations for estimation stability and 20% noise.



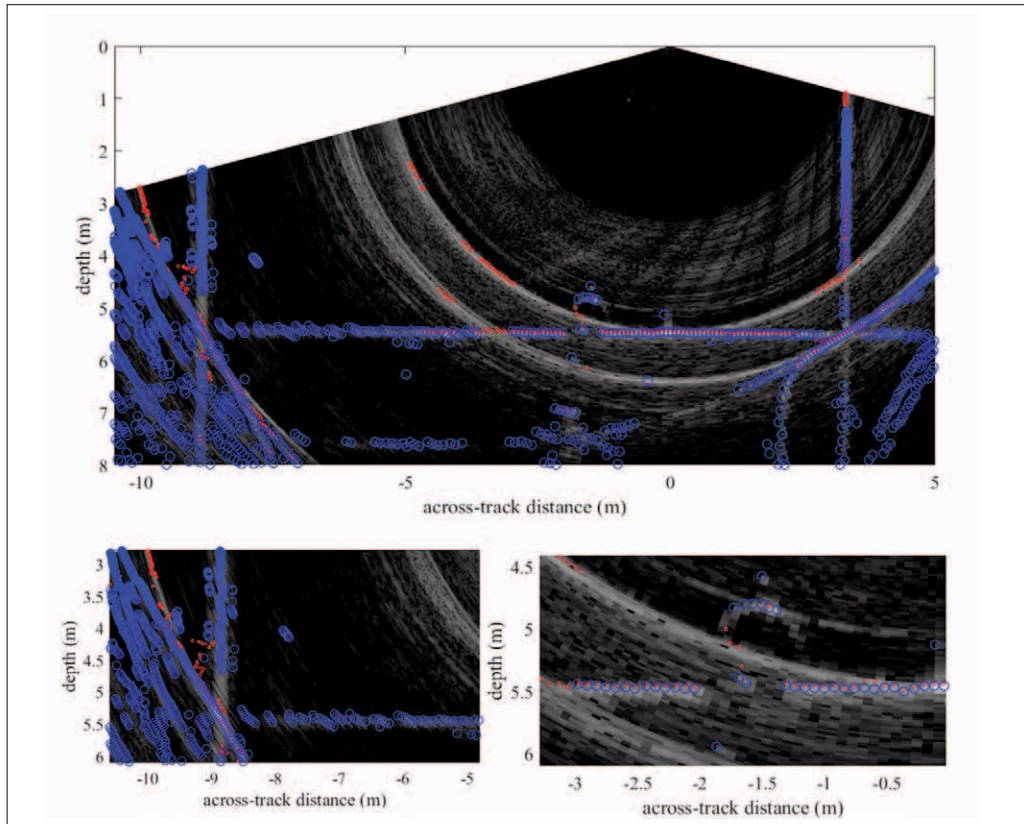

Figure ES-16. A single ping of Reson T50P data from the Chase Lab engineering tank. The backscatter intensity is shown in grayscale. Reson standard bottom detections are shown as red dots. Our multidetect algorithm results are shown as blue circles. The pipe is apparent on the tank bottom at an across-track distance of -1.5 m, and in the insert on the lower right.

### Multidetect Processing

The ability to make multiple detects in each beam of a multibeam sonar offers the promise of improved MBES performance for scenarios where hydrographic targets of interest are not constrained to a single surface (e.g., shipwrecks or submerged structures), where strong targets mask weak ones (e.g., specular reflections from pipelines), and for a variety of other applications where targets of interest are not on the seabed (e.g., fish schools or gas seeps). At least two manufacturers (Kongsberg and Reson) now offer multidetect capability that is integrated with their normal bottom detection routines, although it appears that the approaches are not yet optimized (Figure ES-16). To address this issue, Tom Weber developed an improved multidetect approach that includes a sequenced sidelobe rejection, amplitude threshold application, despeckling, and clustering. Initial results indicate an improvement over the existing approaches even in the difficult situation of a PVC pipe (Figure ES-16).

### Streamlining the NOAA Hydrographic Processing Workflow – HydrOffice

We continue to work closely with the NOAA Office of Coast Survey (OCS) to identify challenges and needs that face those doing hydrographic processing—both in the field and in the office—using current NOAA tools. Since 2015, the Center has collaborated with NOAA HSTB personnel to develop a suite of analysis tools designed specifically to address quality control of problems discovered in the NOAA hydrographic workflow. Built within the HydrOffice tool-support framework (<https://www.hydrooffice.org>), the resulting QC Tools were released in June 2016, and have since been enthusiastically adopted by NOAA field units and processing branches. Yearly updates and edits to NOAA's Hydrographic Survey Specifications and Deliverables are now made with an eye toward automation, anticipating implementation via QC Tools.

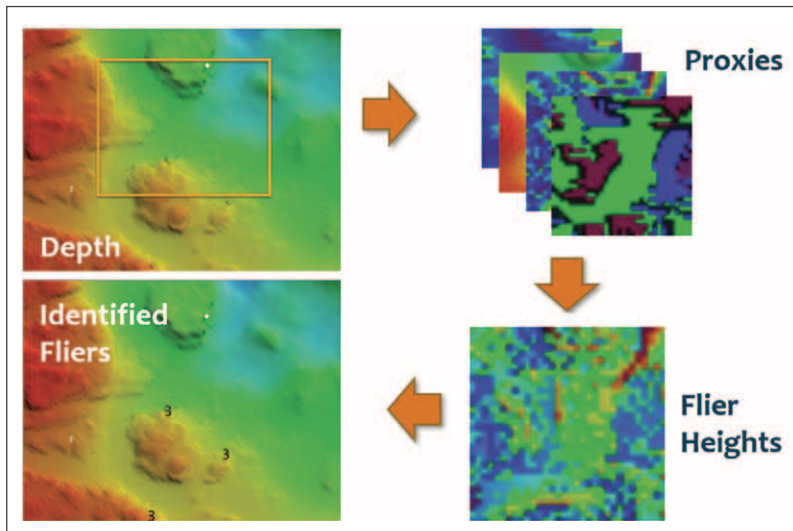

Figure ES-17. Structure of the Anomaly Detector algorithm. This calculates localized flier heights using grid-derived proxies, potentially resulting in fewer false positives and missed fliers.

In the current reporting period, Giuseppe Masetti, Tyanne Faulkes (NOAA PHB), and Brian Calder, in collaboration with Julia Wallace (NOAA AHB), and NOAA HSTB personnel, continued to develop the toolset, including improvements in “Flier Finder” to accommodate variable resolution grids and using grid-derived proxies (Figure ES-17). The application, which aggregates a number of tools within a single GUI, is available through NOAA Pydro (which delivers software to the NOAA hydrographic units) and through the HydrOffice website for non-NOAA users. A number of mapping agencies, NOAA contractors, and other professionals have adopted some of these tools as part of their processing workflow.

QC Tools is in active use in the field, making it a valuable source of feedback and suggestions. Before the beginning of the 2019 field season, a customer satisfaction survey was conducted among NOAA Office of Coast Survey users. Of 39 NOAA respondents, about 75% use QC Tools almost every single working day. This provided evidence that the application is judged to be valuable to the QC Tools community and offered important input for future improvements.

### Chart Adequacy (CA) Tools in HydrOffice

In addition to QC tools, HydrOffice also addresses the issue of Chart Adequacy (CA) which includes the timely and accurate identification of change detection for areas depicted on nautical charts. Currently, this is typically approached through manual or semi-automated processes, based on best practices developed over the years that require a substantial level of effort and human experience (i.e., to visually compare the chart with the newly collected data or to analyze the result of intermediate products). In the current reporting period, Giuseppe Masetti and Christos Kastrisios, in collaboration with Tyanne Faulkes (NOAA PHB), have continued the development of CA Tools, an

application begun in 2018 aiming to act as a container of tools to automate this chart-adequacy task by comparing current Electronic Navigational Charts (ENCs) with newly acquired survey data sets. These tools include the Chart Comparison tool that aims to automate the change identification process and reduce its subjectivity. During the current reporting period, a tool for sounding selection from bathymetric grids using a moving window and point-additive algorithm (Figure ES-18) has been added, improving the algorithm.

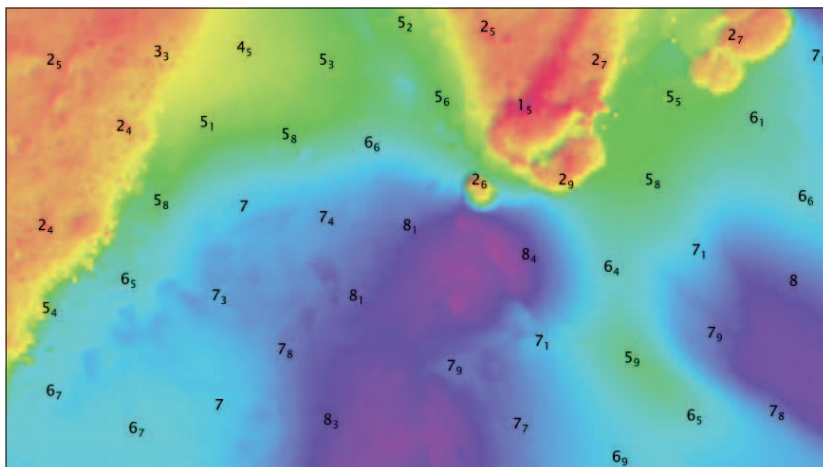

Figure ES-18. Example of output soundings created using the “point-additive” algorithm provided by the Sounding Selection tool recently introduced in CA Tools. The algorithm can take as parameter a user-defined search radius (in meters) or can automatically retrieve the compilation scale from an ENC (if provided).



## Data Processing: Bathymetry - Lidar

We have long recognized that one of the greatest challenges facing the hydrographic community is the need to map very shallow coastal regions where multibeam echo sounding systems become less efficient. New-generation topographic-bathymetric (topobathy) lidar systems have the potential to radically change the way that lidar data is used for hydrographic mapping. Specifically, they generate relatively dense data (compared to traditional airborne bathymetric lidars) resulting in improved data and product resolution, better compatibility with modern data processing methods, and the potential to fill in detail in the shallow regions where acoustic systems are least efficient. Routine ingestion of topobathy data into the hydrographic charting pipeline is problematic. In addition to large volumes of data being generated, which makes processing time-consuming and many tools ineffective, the topobathy data lacks a robust total propagated uncertainty model that accounts for the aircraft trajectory and laser beam ranging uncertainties as well as the behavior of the laser beam in response to waves and the water column.

In conjunction with NOAA's Remote Sensing Division (RSD) and colleagues at Oregon State University (OSU), the Center is developing tools to understand and predict the sensor uncertainty of typical topobathy lidar systems, and adaptations of current-generation data processing tools to the lidar data processing problem.

A Total Propagated Uncertainty (TPU) model for lidars flown by RSD, among others, (cBLUE—Comprehensive Bathymetric Lidar Uncertainty Estimator) was developed and delivered to NOAA/NGS in 2018. Additional lidar training, including cBLUE training, was conducted by Chris Parrish at NOAA RSD in 2019. As the models and concepts of TPU are now starting to be supported within the bathymetric lidar community, standardization and validation of models, and best practices, is seen to be very impor-

tant with respect to vendor and client adoption. OSU and the Center are, therefore, helping to support development and documentation of best practices through stakeholder meetings and interaction with the American Society for Photogrammetry and Remote Sensing (Figure ES-19).

The volume of data generated by modern topobathy lidar systems is immense. Any particular flight could entail collection of perhaps three billion observations (at the lowest capture rate available), which are recorded as several hundred gigabytes of digital records. Brian Calder and Kim Lowell have begun to adapt the CHRT processing approach to the topobathy lidar and have demonstrated that it was possible to extend the basic algorithm with a new "level

Figure ES-19. Documentation of the cBLUE tool in the GitHub repository. A great deal of effort has gone into carefully documenting both the tool itself and its operational use.

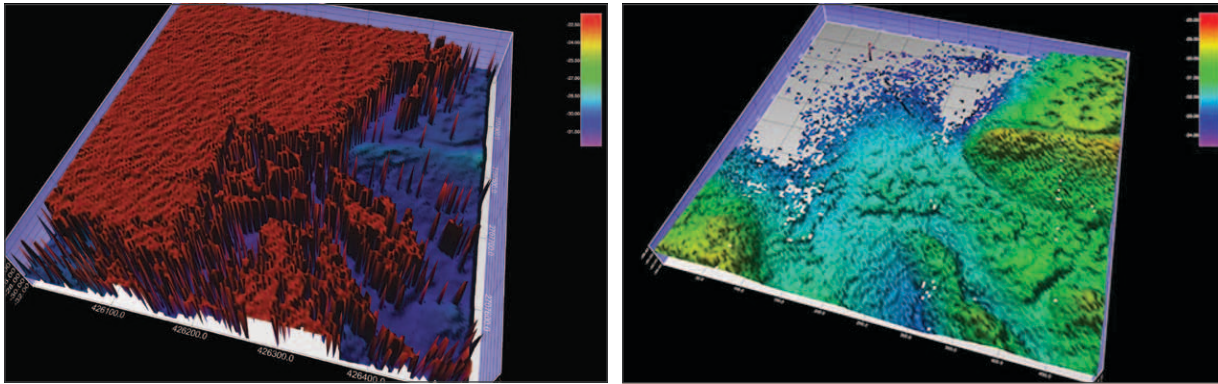

Figure ES-20. Example of depth reconstruction using acoustic-inspired selection rules (left), and the (revised) VQ-HMM approach (right), based on raw (unclassified) LAS files. The noise points in the “standard” selection method (left) are mis-selected reconstructions caused by the density of noise, or lack of actual data, at the estimation points; red points are reconstructions due to surface noise. The VQ-HMM method (right) pre-filters hypotheses and opts to not reconstruct if there are none which resemble the training set’s idea of a seafloor hypothesis.

of aggregation” approach to resolution determination and machine learning based methods (specifically a vector-quantized Hidden Markov Model) to provide clean first-pass estimates of depth from raw data, Figure ES-20. In addition to being objective, this approach significantly reduces the user interaction time, and provides an acoustic-compatible workflow for lidar. The machine learning approach being developed seeks to assign to each return an *a priori* probability of being bathymetry— $p(\text{Bathy})$ —that is incorporated into the disambiguation rules of CHRT. This “certainty index” will ultimately be used within CHRT to influence the decision about which hypothesis for a grid point is considered most likely.

### Processing Backscatter Data

#### Seafloor Backscatter

Along with bathymetry data, our sonar systems also collect backscatter (amplitude) data. Previous progress reports have discussed many of our efforts to understand and quantify the sources of uncertainty in backscatter. We continue to develop techniques to appropriately correct backscatter for instrumental and environmental factors, including the development of approaches to correct for sector beam pattern artifacts, and to correct backscatter mosaics from dropouts due to bubble wash beneath the transducers. Once these corrections are applied, the backscatter data are much more suitable for quantitative analyses that may lead to the long-sought goal of remote characterization of the seafloor.

With an ever-growing array of multibeam sonars operating at different frequencies (and individual systems, displaying greater bandwidth), John Hughes Clarke has been exploring ways to exploit the frequency dependence of seafloor scattering. He has addressed this by looking at inter-frequency offsets and/or changes in the shape of the angular response curves for various sediment types. To that end, new tools and procedures are being developed to allow the user to extract the angular response for site-specific areas at a range of both frequencies and angles (Figure ES-21). This multi-spectral and multi-angular approach offers an exciting new dimension to seafloor characterization.

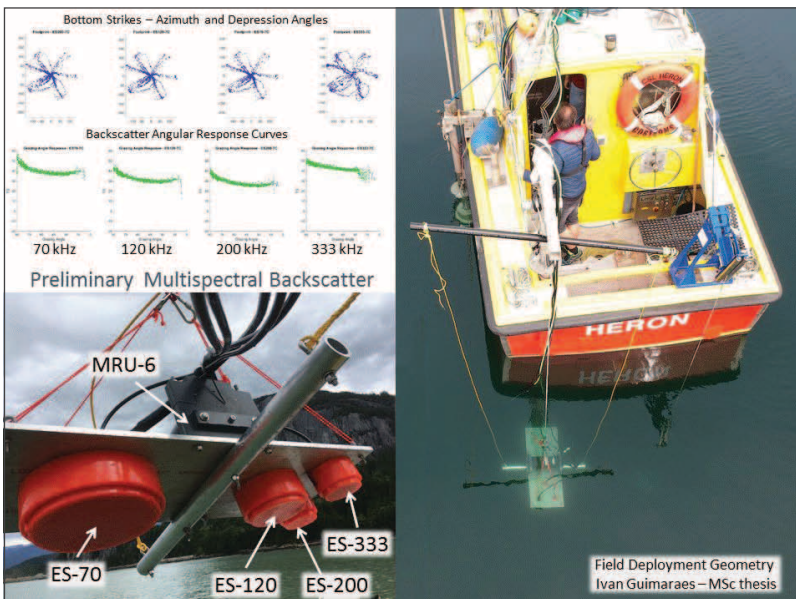

Figure ES-21. Apparatus to collect backscatter data at four frequencies over a range of angles.

Results from these experiments, as well as field work being done at Sequim Bay, WA in collaboration with the University of Washington's Applied Physics Lab, will provide input into the evolution of a new generation of physics-based inversion models. These models, developed by University of Washington, are being incorporated into a new open-source approach to backscatter processing called OpenBST. OpenBST

is a new effort begun at the lab in response to community concerns about inconsistencies in the results of commercial backscatter processing algorithms. This effort, done in collaboration with the vendors of the software packages, seeks to develop community-vetted open-source backscatter processing algorithms that can then be used by vendors to benchmark their approaches (Figure ES-22).

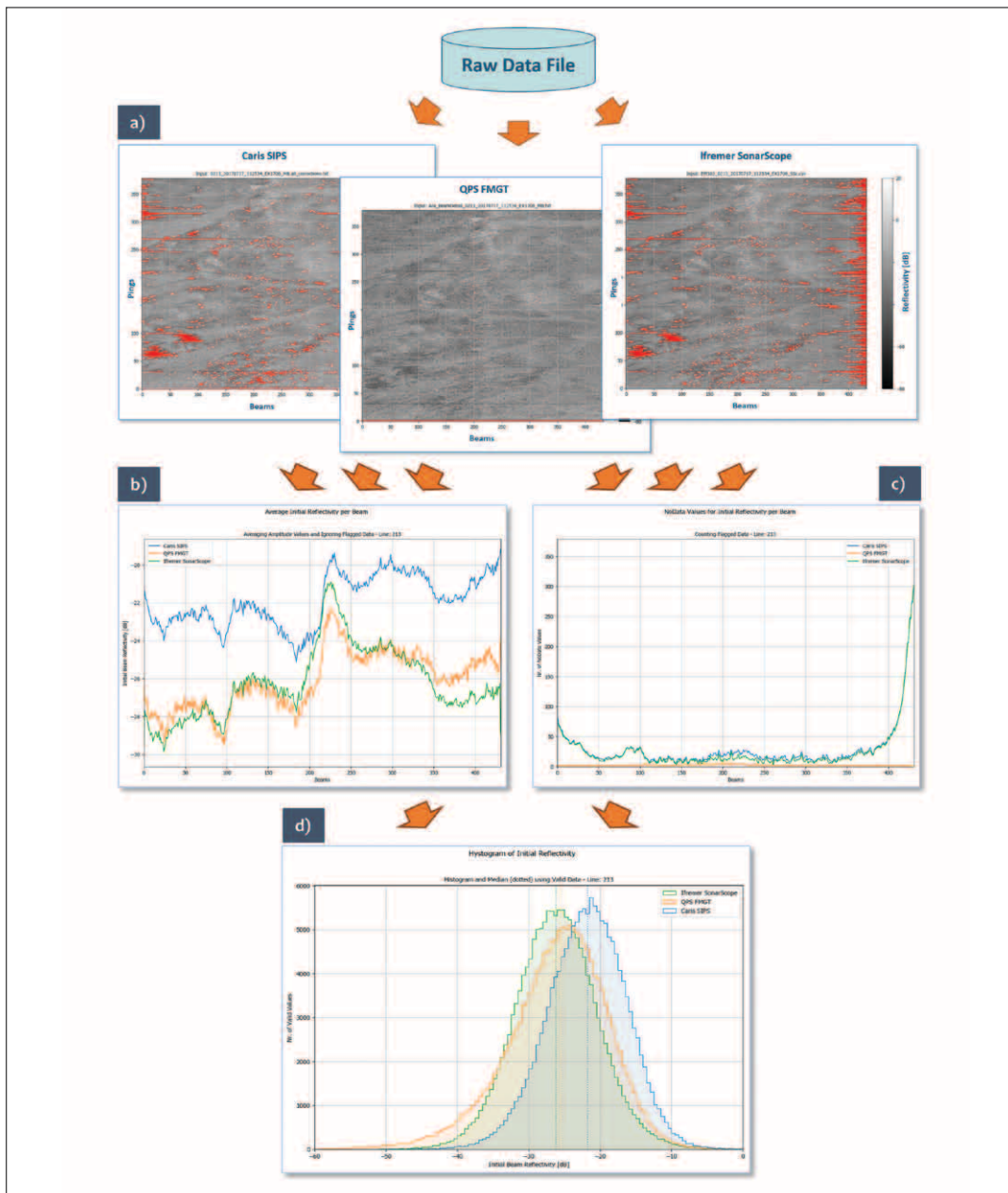

Figure ES-22. Pane a) shows the initial reflectivity values calculated by three software packages (and retrieved from the same raw data file) in a ping-beam geometry. Pane b) plots, for each package, the average value per beam across the whole survey line. Similarly, Pane c) displays the number of no data values per beam. Finally, Pane d) compares the resulting histograms for the three software packages highlighting how the resulting statistical characteristics starts to diverge since the very first processing step.



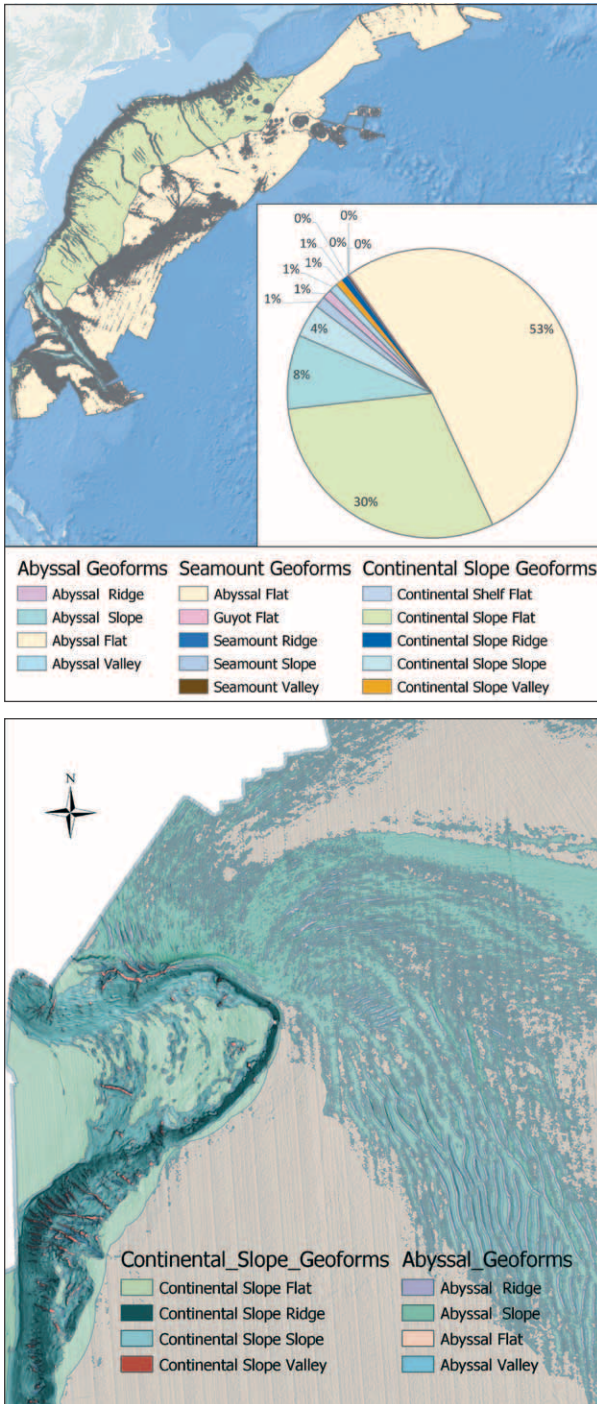

Figure ES-23. Top: CMECS geomorph classifications for the entire Atlantic Margin region. Bottom: CMECS geomorph classes for a portion of the study area highlighting Blake Escarpment, Blake Spur, and Blake Ridge. The figure provides mapped landforms in both the continental shelf and abyssal portions of the area. The massive bedform features in the right corner of the figure are striking, with crest-to-crest distances between 2000-3000 meters. The significant features of the terrain are well represented in the geomorph unit polygons derived from the landforms generated via the automatic delineation algorithm in BRESS.

### Seafloor Characterization and Habitat Mapping

Our efforts to produce more quantitative and consistent backscatter data stem from the great potential of backscatter to be used for the remote characterization of the seafloor and the determination of benthic habitat. To address this issue, Giuseppe Masetti and others have developed an approach to seafloor characterization that first evaluates the context of the area, attempting to take full advantage of both bathymetric and backscatter data to create a bathymetry- and reflectivity-based estimator for seafloor segmentation (BRESS). The initial phase of the algorithm performs a segmentation of the bathymetry surface through the identification of contiguous regions of similar morphology, for example valleys or edges. The backscatter for these regions is then analyzed to derive final seafloor segments by merging or splitting the regions based on their statistical similarity. The output of BRESS is a collection of homogeneous, non-overlapping seafloor segments, each of which has a set of physically-meaningful attributes that can be used for task-specific analysis (e.g., habitat mapping, backscatter model inversion, or change detection).

This past year, BRESS has been applied to a bathymetric synthesis generated from all available high-quality data from the U.S. Atlantic Margin canyons collected as part of the U.S. Extended Continental Shelf Project. This effort used the automatic segmentation capabilities of BRESS to identify landform features from the bathymetry of the region, then used ArcGIS Pro to translate these results into complete coverage geomorphology maps of the region utilizing the Coastal and Marine Ecological Classification Standard (CMECS) to produce broad scale geomorphology maps as a key component of marine habitat characterization in support of ecosystem-based management (Figure ES-23). These data are being ground-truthed through the quantitative evaluation of ROV video data collected by the NOAA vessel of exploration, Okeanos Explorer (Figure ES-24).

The high-resolution imagery that we use to ground-truth our acoustic data provides a precise view of seafloor environments and allows insight into important biological and physical metrics that gives indication regarding the health and well-being of seafloor habitats. With current technology, it is possible to collect and store large amounts of digital imagery data. The annotation of this data however, is an expensive and time consuming task which is almost



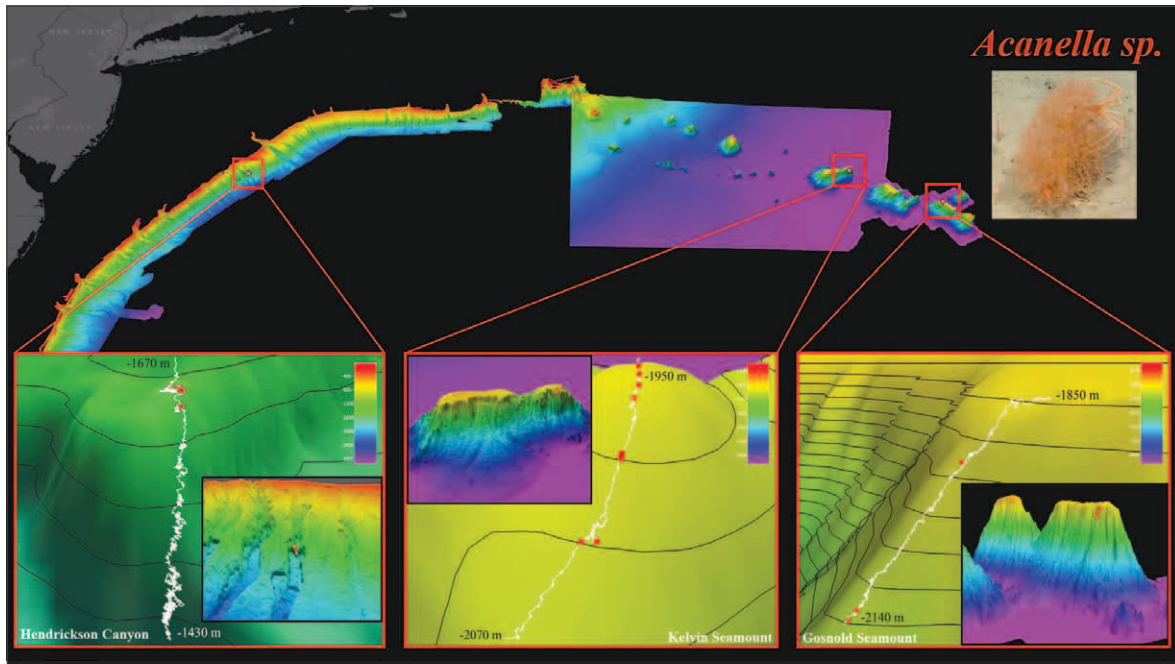

Figure ES-24. ROV tracks showing the distribution of bamboo corals collected in Hendrickson Canyon, Kelvin and Gosnold Seamounts.

always preformed manually by a trained expert. In an attempt to reduce the amount of time required to annotate data, we are exploring methods that use computer vision and deep learning algorithms to assist in the autonomous annotation of imagery data. We have tested and refined our methods on still images of underwater video footage of coral reef patches collected from the Florida Keys, and have generated highly representative samples of each taxonomic class category, limiting the overall annotations needed to be done manually before training an image classifier capable of providing auto-

nomous annotations on the remainder of the dataset. Once the deep semantic segmentation model was trained, it was applied to the still images used for 3D reconstruction of coral reef patches, providing a 3D assessment of the spatial distribution of different taxa within a patch reef (Figure ES-25).

Building on our expertise in scientific data visualization we have been exploring the use of virtual reality-based 3D reconstructions of seafloor imagery, including coral habitats, which includes advanced interaction techniques, and interactive analysis tools.

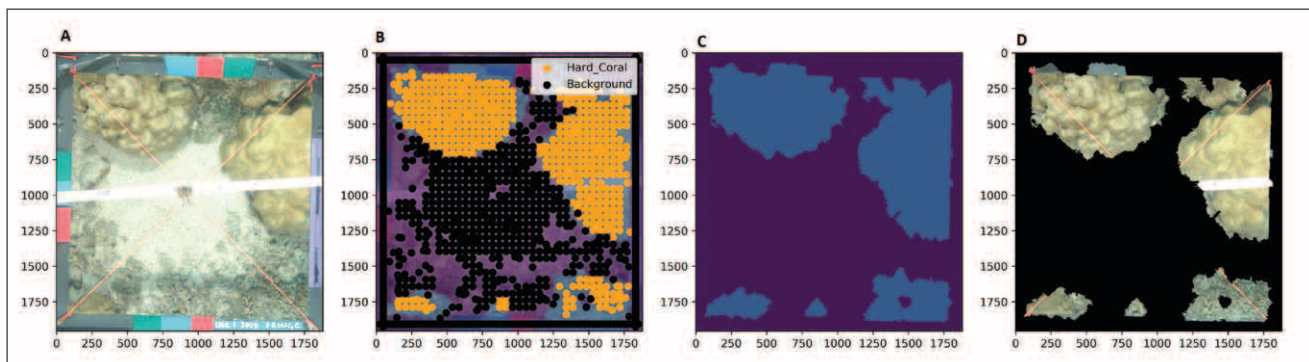

Figure ES-25. Process of generating masks for each class category and its use as training data for the deep semantic segmentation algorithm: (A) sample image from the MLC (2000x2000 pixels) dataset; (B) image with more labelled points by trained artificial intelligence that act as autonomous annotator; (C) groupings of pixels belonging to the same class category created by a SLIC algorithm; (D) masked class images.

The system developed provides an immersive 3D environment through a Vive VR headset, which contains a 3D reconstruction of seafloor features built using “structure from motion” techniques based on diver video and still imagery. The VR environment is free-area tracked, meaning that the user can simply physically walk around the feature (e.g., a coral head) to shift viewpoint, and contains two hand-held controllers that allow the user to shift zoom, manipulate the environment, and summon menus and interaction tools to, for example, measure interstitial dimensions within the feature (Figure ES-26). Additionally, due to careful selection of a cross-platform toolkit, the same visualization could be implemented for other environments, including web, and mobile systems, making it a potential outreach modality. We are currently working on combining this work with that on seafloor and target characterization so that the 3D environment can be used to provide ground-truth to train the classification algorithms, and the results of the classification can be displayed in the 3D environment for further analysis and insight.

## Processing Backscatter Data

### Water Column

The sonars we use to map the seafloor can also collect acoustic data from the water column. Building on work done in response to the Deep Water Horizon spill, the Center has pioneered techniques to capture, process, and visualize water column acoustic data, particularly with respect to the location and quantification of gas and oil seeps. As these tools evolve, we seek to push the limits of quantitative midwater mapping, developing tools to measure flux of gas and identify the nature (oil, water, gas, etc.) of mid-water targets. This past year has presented a number of opportunities to collect water column data and further our development of processing and visualization approaches. One of the foci for water column target detection was a research cruise in New Zealand on the R/V *Tangeroa*. The cruise involved the use of a large suite of acoustic echo sounding equipment for quantitatively assessing both the seafloor and the water column, including several broadband

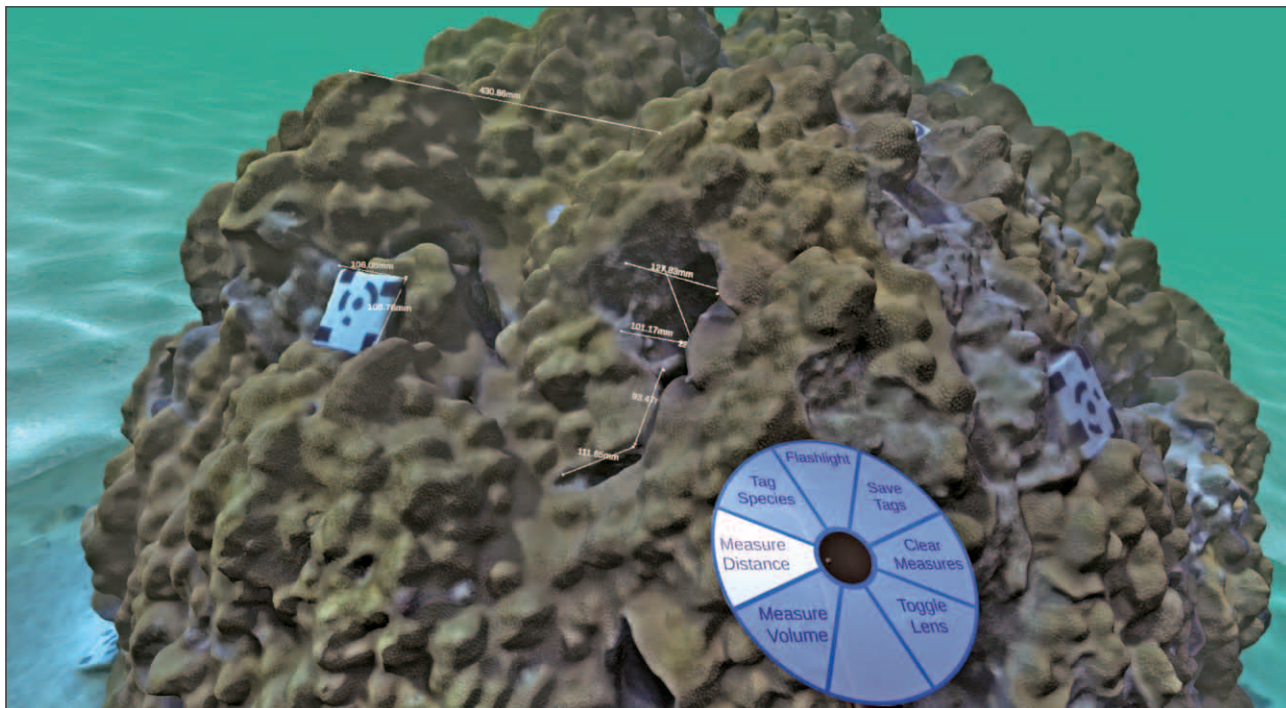

Figure ES-26. Screenshot from the updated CoralVis VR software, showing a high-fidelity coral model (generated by Jordan Pierce and Jennifer Dijkstra) and 3D measurements (white lines/text) made using tools accessed via the radial-menu (blue disc) attached to the handheld controller.



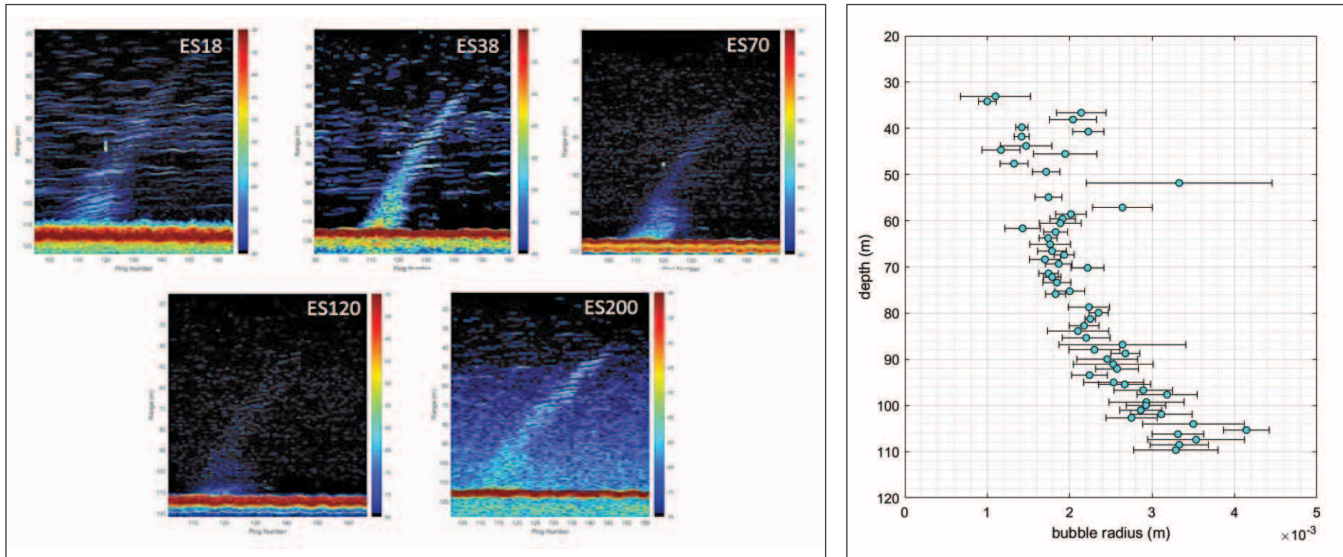

Figure ES-27. Left: Echograms showing the bubble stream as viewed at different frequencies. Right: Derived bubble radii from a single ES200 pass.

split-beam echo sounders operating at frequencies ranging from 15-25 kHz, a 30 kHz EM302, and a 200 kHz EM2040. Ground truth data were collected using a camera tow-sled and water sampling. The Center contributed a synthetic gas bubble generator, developed by former student Kevin Rychert, which was used to test detection limits and to perform cross-calibrations between different systems. Graduate student Elizabeth Weidner analyzed bubble generator data collected as part of a dedicated experiment aimed at calibrating multibeam water-column backscatter measurements with the pan & tilt system (PTS) split-beam echosounder system (Figure ES-27 Left). Individual bubbles were sampled at the point of maximum acoustic response and the bubble range, electrical phase angle, peak acoustic intensity, and vessel motion were extracted. Bubble radii for each detection were then computed through comparison to acoustic scattering models, providing bubble size as a function of water depth (Figure ES-27 Right).

The techniques we have been developing to quantitatively monitor oil and gas flow acoustically, has been applied to the question of leak rates at wrecked and leaking oil wells of the Taylor Energy site in the Gulf of Mexico. As part of his

thesis work under the supervision of Tom Weber, Scott Loranger was able to estimate the total flux of oil associated with the lower portion of the plume to be in the range of 150-350 barrels per day, assuming the entire lower portion of the plume is oil. These estimates were in reasonable agreement with later ground-truth measurements (Figure ES-28).

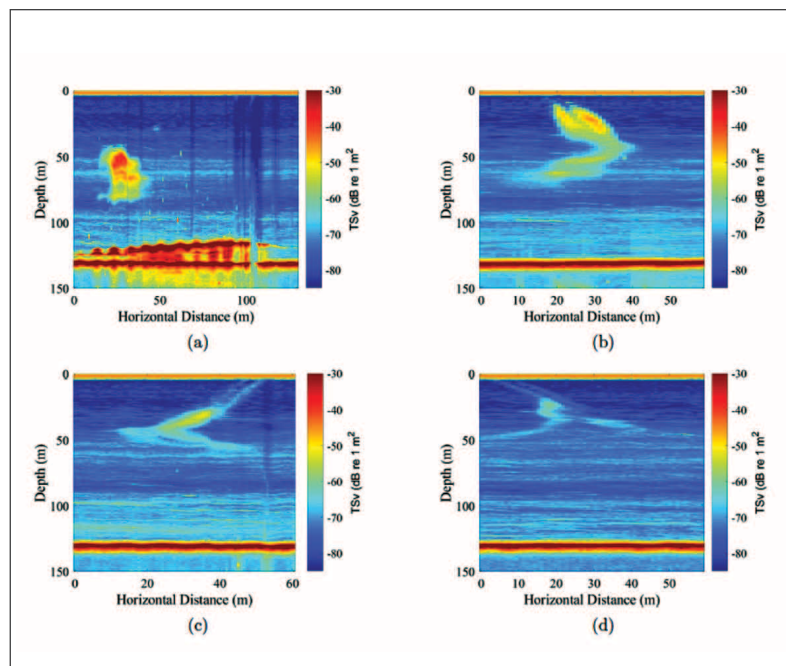

Figure ES-28. From Scott Loranger's thesis: Echograms for cross sectional passes downstream of the Taylor seep origin. Echogram (a) is the closest to the origin (58 m), followed by (b) (115 m), then (c) (187 m), and (d) (235 m).



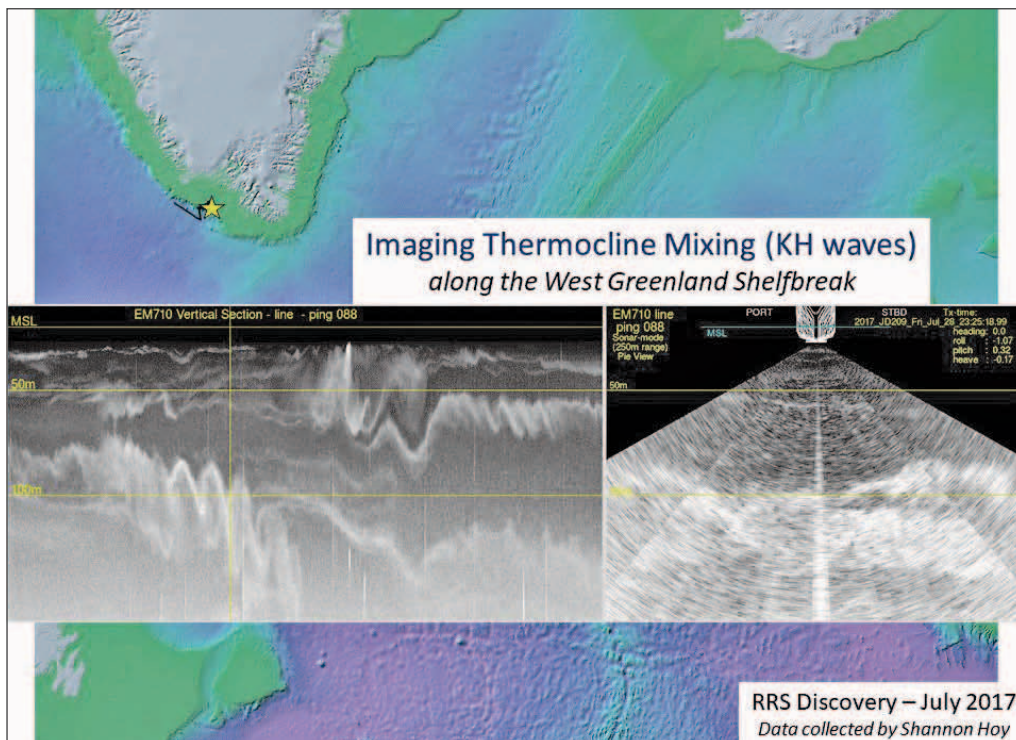

Figure ES-29. Sections of Kelvin-Helmholtz waves developed in the thermocline, acquired using an EM710 in sonar mode (250m range) while operating an EM122 in slope depth water off the West Greenland Continental Shelf (RRV Discovery).

One of most exciting aspects of our water-column work has been the demonstration that both multibeam and broadband single beam sonar can show oceanographic features with remarkable detail. This was previously demonstrated in the high Arctic where our sonars were able to discern very small impedance contrasts that represented small thermohaline steps and the thermocline. This past year, John Hughes Clarke and Shannon Hoy demonstrated the feasibility of mapping Kelvin-Helmholtz waves using an EM710 in sonar mode with a 250m range in the Labrador Sea (Figure ES-29). Additionally, Elizabeth Weidner has been able to track the oxygen minimum zone in the Baltic Sea with a broadband echosounder (Figure ES-30).

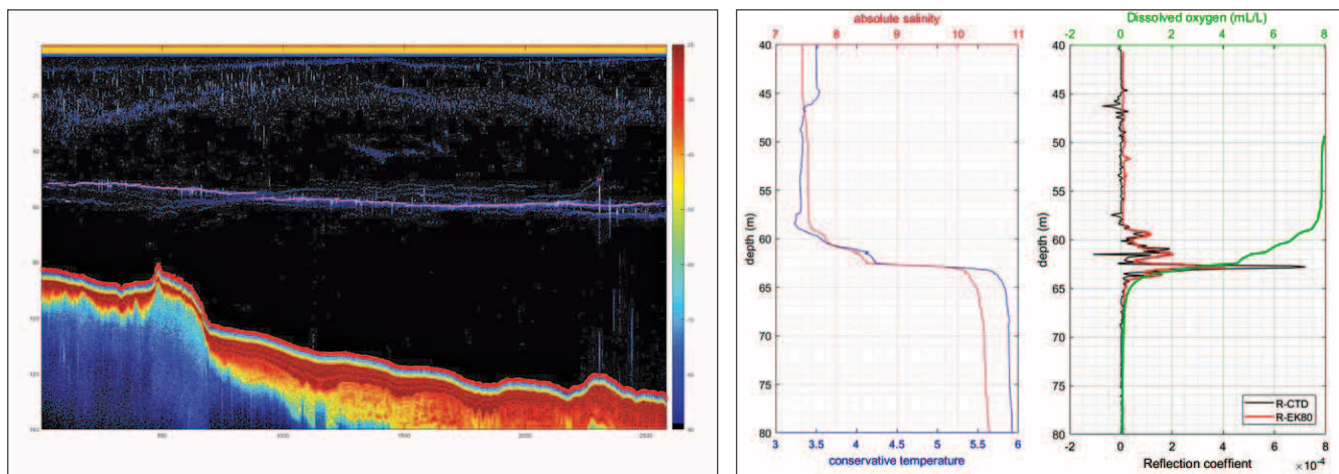

Figure ES-30. Left: Echogram of the tracked oxygen minimum location along transect in the Baltic. Right: Reflection coefficient calculated at CTD site through oxygen minimum zone. The black reflection coefficient profile corresponds to the CTD estimate and the red to the acoustic estimate; green line is dissolved oxygen.

## Programmatic Priority 2: Transform Charting and Navigation

### Chart Adequacy and Computer Aided Cartography

#### Managing Hydrographic Data and Automated Cartography

A long-term goal of many hydrographic agencies is to automatically construct cartographic products from a single-source database populated with a consistent representation of all available data at the highest possible resolution; in many cases, the goal is to populate with gridded data products. Such an approach has the potential to radically improve the throughput of data to the end user, with more robust, quantitative, methods, and to improve the ability to manipulate chart data much closer to the point of use. Our efforts under the second programmatic priority have been focused on various aspects of meeting this goal, including exploring more robust approaches for sounding selection verification (Figure ES-31), developing automated techniques to ensure vertical continuity on charts, approaches to the visualizing uncertainty on Electronic Nautical Charts (ENCs; Figure ES-32), for the automatic compilation of ENCs, and automated approaches to generalizing nautical charts.

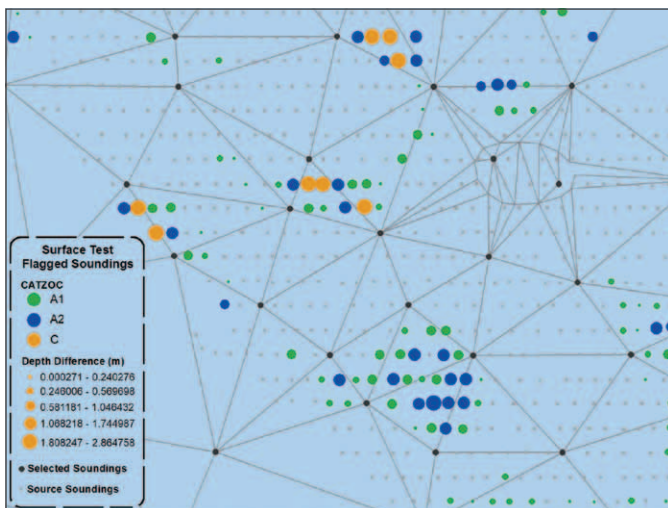

Figure ES-31. Soundings flagged by a newly developed toolset that includes triangle, edge, and surface tests now being tested by MCD.

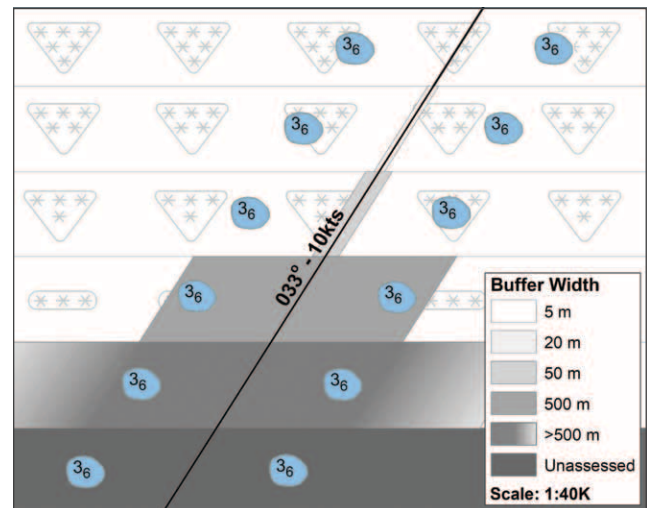

Figure ES-32. A proposed approach to visualizing dangers along proposed route. Zone width is set equal to the horizontal uncertainty in the area.

#### Immersive 3D Data Cleaning

No matter how comprehensive and effective automated processing tools become, there will likely always be some data that need to be examined and manipulated by hand by a human operator. As part of the ongoing effort to explore new interfaces for hydrographic data manipulation, therefore, Tom Butkiewicz and graduate student Andrew Stevens are creating an immersive 3D, wide-area tracked, sonar data cleaning tool. The system developed relies on an HTC Vive virtual reality (VR) system, which consists of a head-mounted display (HMD), two hand-held six-degree-of-freedom (6DOF) controllers, and a laser-based wide-area tracking system which accurately and rapidly calculates the positions of all of these components in a 5×5m tracked space.

To evaluate the viability of using an immersive system on a moving vessel, we conducted an informal evaluation in a seasickness-inducing simulator (Figure ES-33), and found that adding a virtual horizon and moving the surroundings in our virtual environment to match vessel motion, greatly reduced the potential for motion sickness, indicating that the use of immersive VR technologies aboard underway ships may be feasible. Experiments comparing cleaning performance between the Center's novel VR interface and a generic desktop monitor and mouse/keyboard based interface representative of traditional software packages showed a clear advantage when using the VR interface with regard to completion time, while errors were generally equivalent between the interfaces.



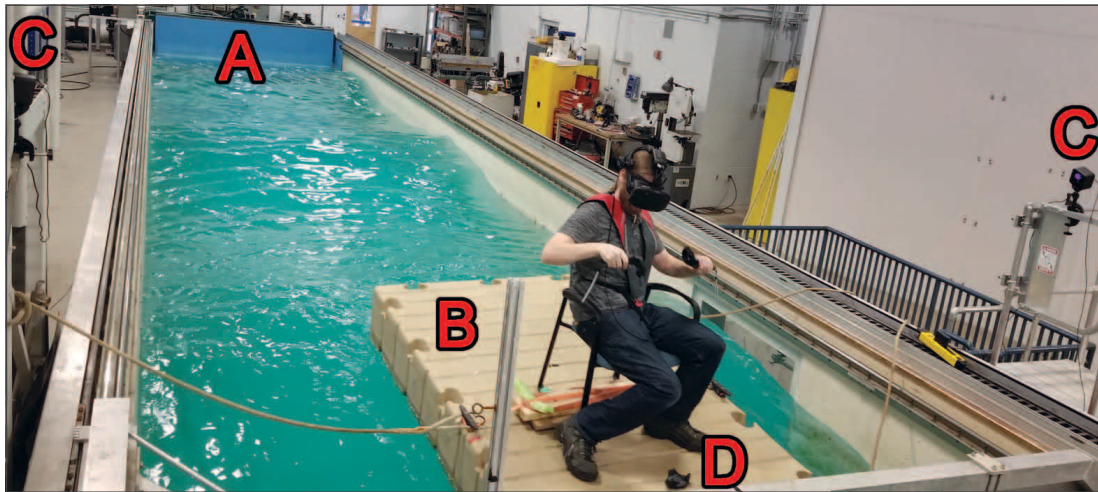

Figure ES-33. Nauseagenic testing setup. The paddle (A) at the end of the tank creates waves which induce motion on the floating platform (B). The tracking cubes (C) on the sides of the tank provide a fixed reference space, while a tracking device (D) provides the platform's pose, which is used to compensate the visuals in the virtual environment to match the felt motion, reducing motion sickness.

However, because users can be reluctant to use immersive interfaces and wear head mounted displays for long periods of time, we have also developed a desktop monitor based, non-immersive version of our editing software (Figure ES-34). While users do not get the same depth perception and head coupling benefits, the handheld six-degree-of-freedom controllers are still a better interface than a mouse for the inherently 3D task, which preserves much of the benefits our immersive system presents over traditional interfaces. We have also added support for lidar point cloud editing.



Figure ES-34. Interactive point cloud editor being used on a standard 2D desktop monitor, where the 6DOF handheld controllers can be used to "reach into the screen" and edit, manipulate, reposition, and scale data similar to the immersive mode.



## Comprehensive Charts and Decision Aids

### Digital Coast Pilot – Chart Update Mashup

The Sailing Directions (SD)/Coast Pilot (CP), a textual aid to marine navigators, has traditionally been a product distributed in print or as PDFs—forms unable to take full advantage of the detailed georeferenced data it includes. One of our goals as we explore the “chart of the future” is to be able to use supplementary data for the electronic nautical chart (ENC) to augment and add value to the mariner’s experience. The IHO is in the process of creating standards for ECDIS/ENC called S-100 (replacing the old S-57 standard). The IHO Nautical Information Provisions Working Group (NIPWG) is responsible for the Nautical Textual Information (NTI) contained within the Coast Pilot. Working to support the mandate of NIPWG, we are investigating how to parse the unstructured NTI into structured data models so that this data can be used in electronic chart displays. We are also investigating how well-structured/machine-readable information can best be displayed in an interactive display and are looking for other ways in which it can be used to support the mariner. Briana Sullivan has developed a web-based, interactive test-bed (iCPilot) for evaluating new approaches for presenting NTI (Figure ES-35).

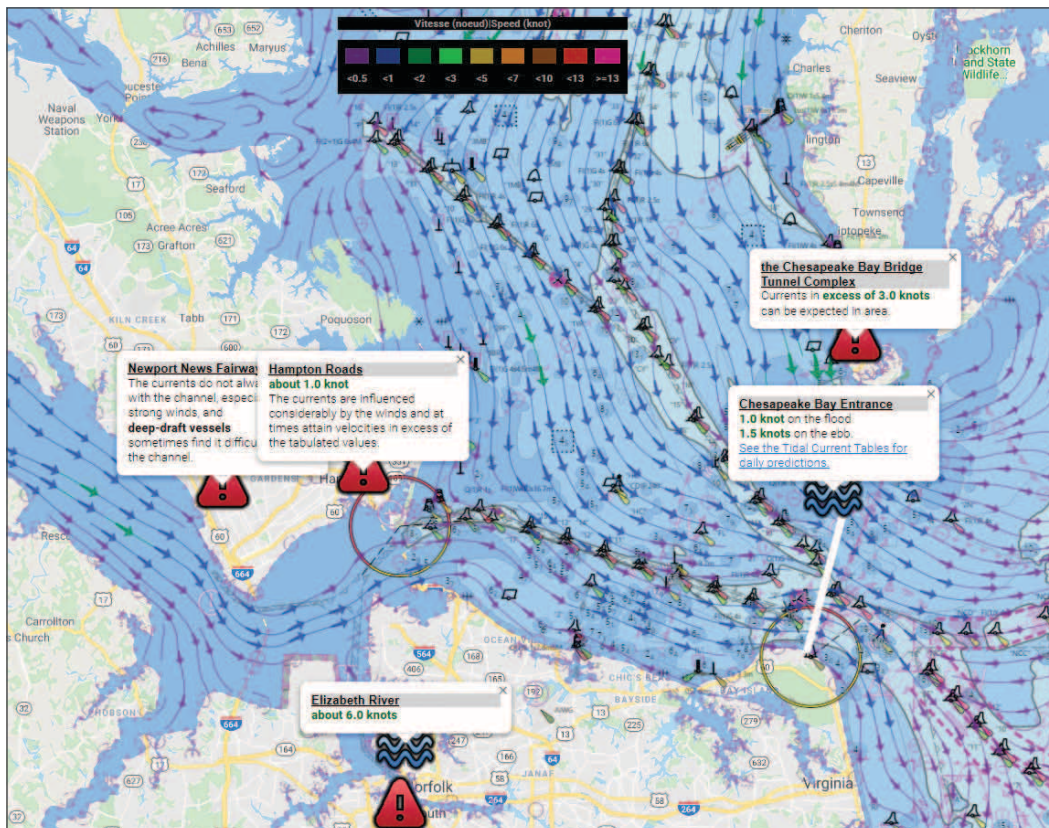

Figure ES-35. iCPilot prototype showing S-111 surface current data in conjunction with related Coast Pilot textual data.

### Augmented Reality for Marine Navigation

In concert with our activities to extend and enhance current charts and navigational support tools (like the Coast Pilot), we are exploring how new developments in interactive data visualization—including augmented and virtual reality—may play a role in the future of marine navigation. Augmented Reality (AR), which is the superimposition of digital content directly over a user’s real-world view, is an emerging technology that may have great potential for aiding safe marine navigation.

Tom Butkiewicz has continued to develop a dynamic and flexible bridge simulation for experimenting with a range of possible AR devices and information overlays across different times-of-day, visibility, and sea-state/weather. This simulation allow for safe evaluation in a more diverse set of conditions than are available on our research vessel. The project's goals include identifying what technical specifications are required for future AR devices to be useful for navigation, what information is most beneficial to display, and what types of visual representations are best for conveying that information. Butkiewicz has completed a physical interface for piloting the virtual boat. The controls include a full-size ship's wheel that provides realistic force feedback and a throttle. These are mounted to a portable platform with an integrated tracker which keeps the virtual bridge's controls

and real controls perfectly aligned so that one can always reach out and grab them within the simulator (Figure ES-36).

Using these controls, we have conducted a number of studies focused on understanding the effects of field-of-view on the usefulness of the AR overlays for marine navigation tasks, including the use of an eye-tracker that can accurately detect what participants are looking at 120 times per second. While participants navigated the course, we used the eye-tracker to record how often they looked up at the ECDIS, which is a useful metric for understanding the effects of field-of-view on situational awareness. The results of the study indicated great potential for AR to aid in safe marine navigation by keeping mariner's eyes on the water.



Figure ES-36. Upper: Simulated augmented reality overlay of nautical chart information. Lower: The virtual bridge and AR simulator. Lower Left: The physical controls used to pilot the boat. Above Right: The virtual ECDIS display above the bridge windows, showing a track-up OpenCPN chart with the same trackline and waypoint. Below Right: The view from the virtual bridge within the field-of-view study environment, showing ship traffic and AR trackline to next waypoint.



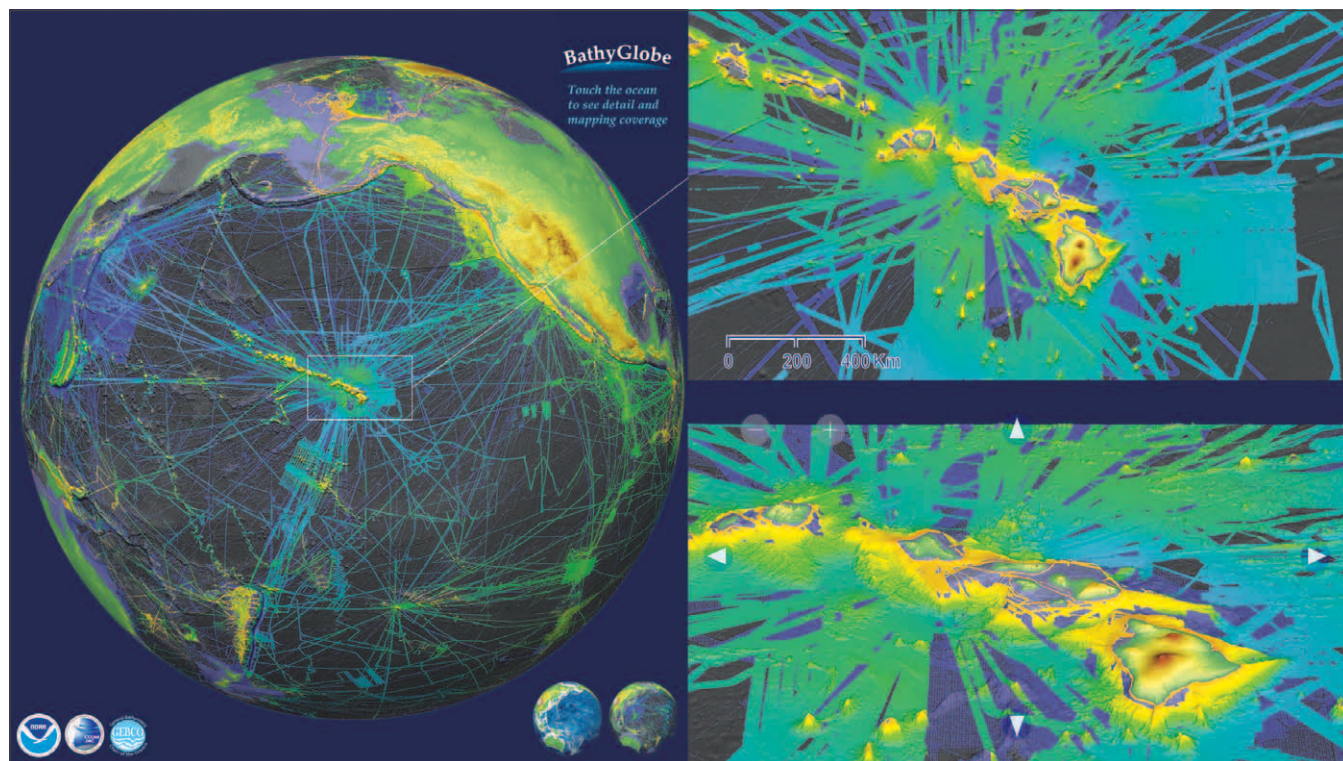

Figure ES-37. BathyGlobe, showing the newest GEBCO 2019 data with a colormap designed to emphasize areas with multibeam coverage.

### Digital Bathymetric Globe (BathyGlobe)

Within the context of our visualization activities, Colin Ware has initiated the “BathyGlobe” project, a new effort focused on developing an optimal display for global bathymetric data. One of its goals is to provide support for the Seabed 2030 initiative to heighten awareness of the extent to which the seabed has and has not been mapped. The BathyGlobe presents the actual scaled coverage of existing bathymetric data on an interactive globe display, clearly demonstrating how little of the world’s ocean has real bathymetric data. Numerous enhancements have been added to the BathyGlobe including, the ingestion of the newest GEBCO 2019 grid and enhanced color maps and 3D viewing (Figure ES-37). In concert with these efforts, Ware is also working on optimized gridding algorithms for multi-resolution global bathymetric data sets.



## Programmatic Priority 3: Explore and Map the Continental Shelf

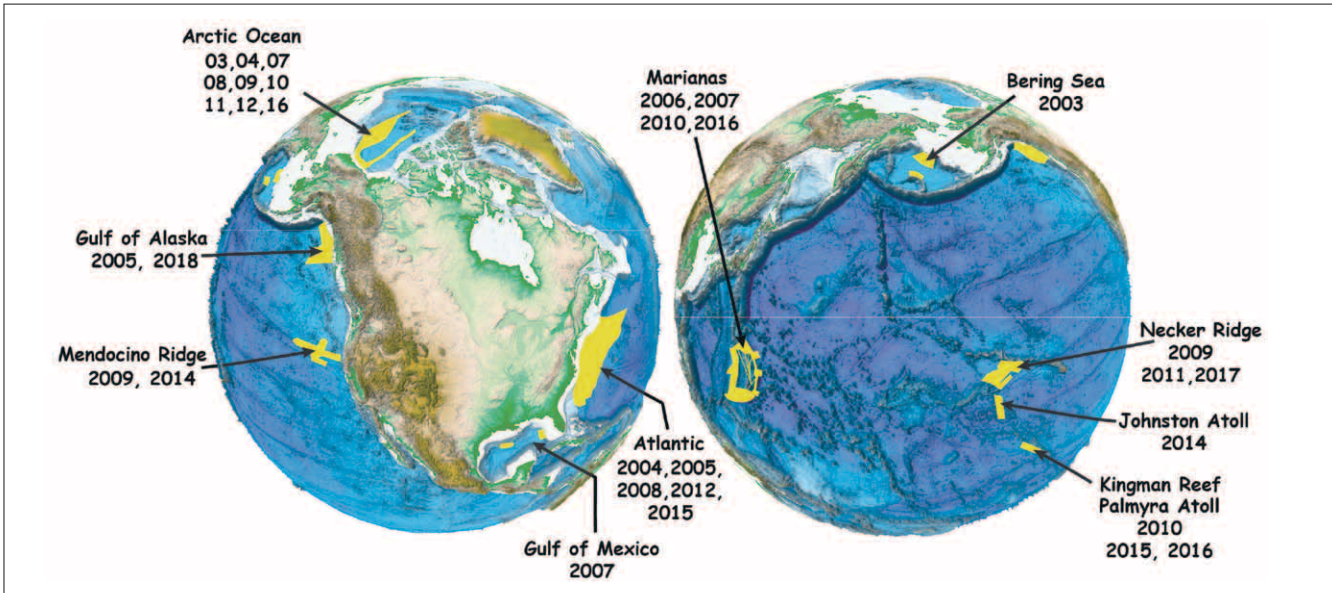

Figure ES-38. Summary of Law of the Sea multibeam sonar surveys mapped by the Center. Total areas mapped represents more than 3.1 million square kilometers since 2003.

Recognizing that the United Nations Convention on the Law of the Sea (UNCLOS), Article 76 could confer sovereign rights to resources of the seafloor and sub-surface over large areas beyond the U.S. 200 nautical mile (nmi) Exclusive Economic Zone (EEZ), Congress (through NOAA) funded the Center to evaluate the

nation’s existing bathymetric and geophysical data holdings in areas surrounding the nation’s EEZ in order to determine their usefulness for establishing an “Extended” Continental Shelf (ECS) as defined in Article 76 of UNCLOS. This report was submitted to Congress on 31 May 2002.



Figure ES-39. Home page of the Center’s GIS portal.

Following up on the recommendations made in the study, the Center was funded (through NOAA) to collect new multibeam sonar (MBES) data in support of a potential ECS claim under UNCLOS Article 76. Mapping efforts began in 2003. Since then, the Center has collected more than 3.1 million square kilometers of new high-resolution multibeam sonar data during 35 cruises— nine in the Arctic, five in the Atlantic, one in the Gulf of Mexico, one in the Bering Sea, three in the Gulf of Alaska, three in the Necker Ridge area off Hawaii, three off Kingman Reef and Palmyra Atoll in the central Pacific, five in the Marianas region of the western Pacific, and two on Mendocino

Fracture Zone in the eastern Pacific (Figure ES-38). Summaries of each of these cruises can be found in previous annual reports and detailed descriptions and access to the data and derivative products can be found at [www.ccom.unh.edu/law\\_of\\_the\\_sea.html](http://www.ccom.unh.edu/law_of_the_sea.html). The raw data and derived grids are also provided to the National Center for Environmental Information (NCEI) in Boulder, CO and other public repositories within months of data collection and provide a wealth of information for scientific studies for years to come.

Current year activities focused on writing up ECS results and revising and updating the Center's ECS website including a transfer to ArcGIS Pro and an enterprise online GIS solution <https://maps.ccom.unh.edu/portal/home/> (Figure ES-39). This has allowed a range of new visualization and interactive features including color palettes based on dynamic range, real-time calculation of single and multiple hill-shades, real-time calculation of contours and many enhanced query activities. (Figures ES-40 and ES- 41).

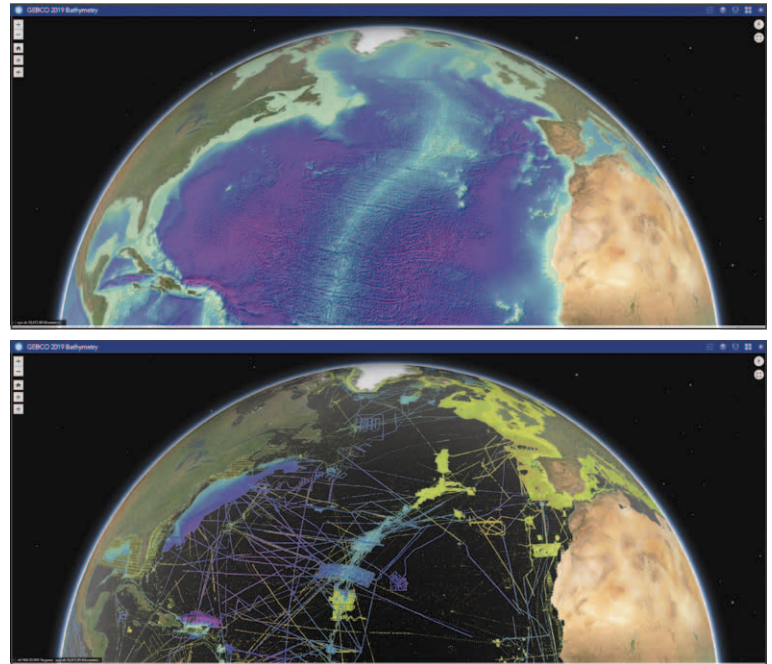

Figure ES-40. Top: The GEBCO 2019 bathymetry grid. Bottom: The same grid with areas containing interpolated values set to black and areas composed of pre-generated grids as yellow.

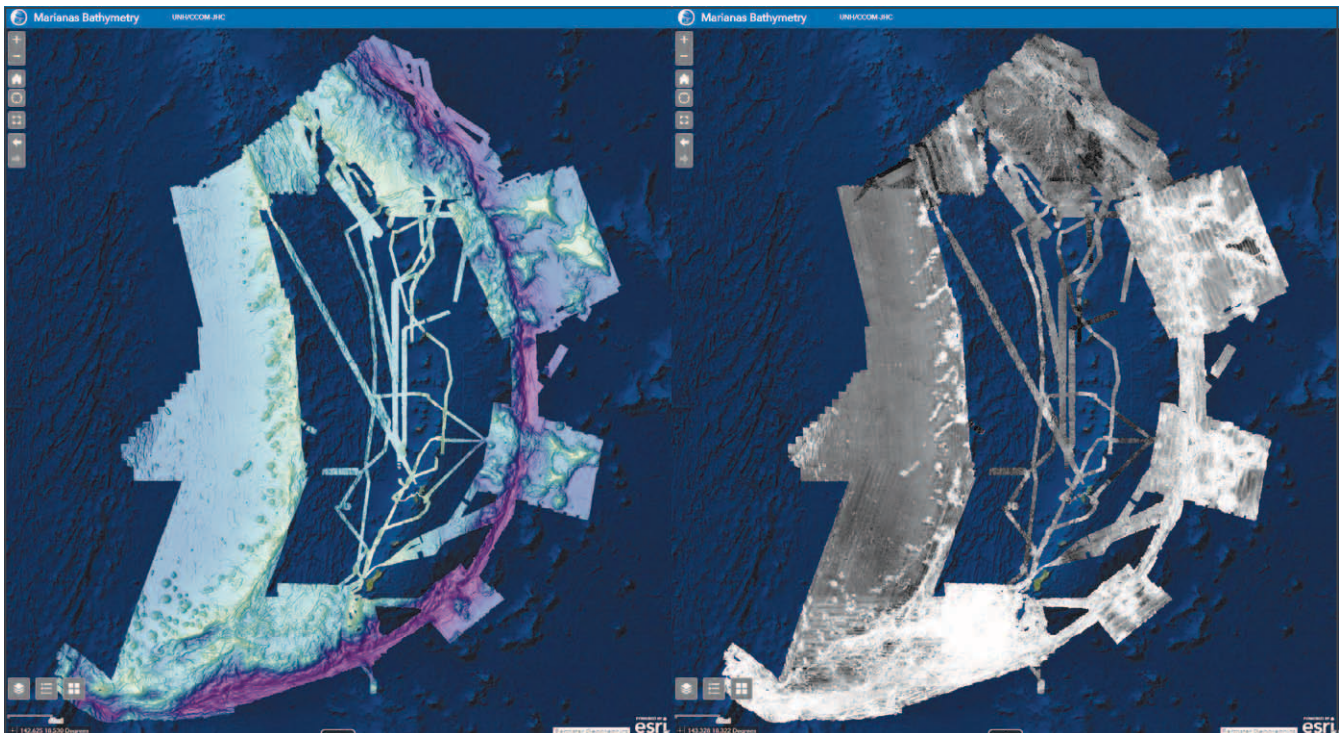

Figure ES-41. Primary bathymetry and backscatter syntheses for the Marianas region from ECS data and other sources.



## Programmatic Priority 4: Develop and Advance Hydrographic and Nautical Charting Expertise

### Acoustic Propagation and Marine Mammals

An important goal of the Center is to adequately model, and validate at sea, the radiated field from multibeam echo sounders (MBES) so that we may provide the best available information to those interested in investigating potential impacts of radiated sound on the environment. In support of this goal, Center researchers have organized and undertaken several cruises to Navy calibration ranges designed specifically to help characterize the ensonification patterns of deep water multibeam sonars. The first of these cruises was conducted in early 2018 at the Southern California Offshore Range (SCORE), located in the San Nicholas Basin off San Clemente Island, CA using a 12 kHz EM122 on the R/V *Sally Ride*, followed by a second experiment at the AUTECH range in the

Bahamas using a 30kHz, EM302 on the NOAA Ship *Okeanos Explorer*, and a third back at the SCORE range in early 2019. In the latter two experiments, we deployed custom-designed moorings (Figure ES-42) in addition to the Navy hydrophones.

The results of these experiments have confirmed our initial results demonstrating some unexpected behaviors in the radiation patterns of the multibeams and have now allowed us to measure absolute source levels (Figure ES-43).

### Impacts of Sonars on Marine Mammals

The experiments at the Navy hydrophone ranges also provided an opportunity to track the behavior of resident marine mammal populations whose vocalizations during foraging can be monitored on the Navy hydrophones during the operation of the multibeam sonars. We have now looked at the feeding behavior of Cuvier's beaked whales at the SCORE range for two periods of multibeam operation (2017 and 2019). The study design and analysis parallel studies done by researchers that examined the effect of mid-range naval sonars on Blainville's beaked whales foraging at the Atlantic Undersea Test and Evaluation Center (AUTECH).

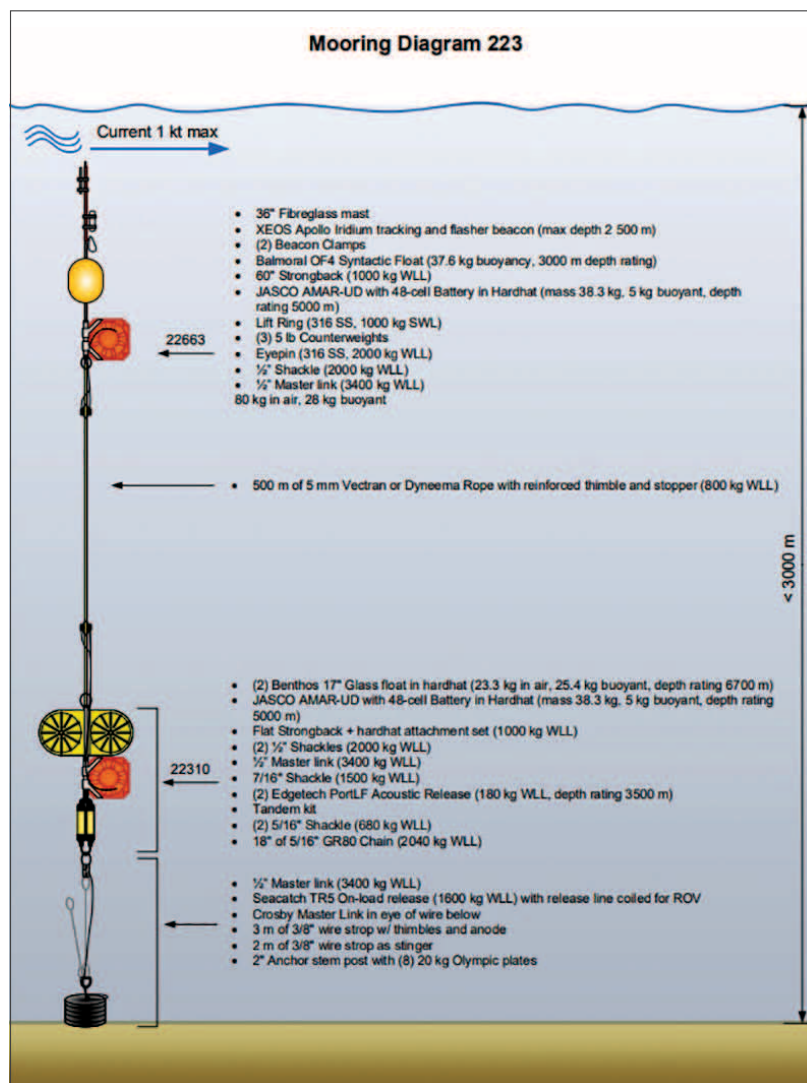

Figure ES-42. Diagram of mooring supplied by JASCO and deployed at both AUTECH in December 2018 and at SCORE in January 2019.



Echolocation clicks are produced by Cuvier's beaked whales as they hunt for prey. The period of vocal activity during a foraging dive is referred to as the group vocal period (GVP). Group vocal periods were automatically detected using software that identified clicks, combining them into click trains based on species-specific characteristics. Closely associated click trains are grouped into GVPs on a per-hydrophone basis. GVP characteristics are then used as a proxy to assess the temporal distribution of foraging activity across six exposure periods with respect to multibeam activity at the range. These characteristics included the number of group vocal periods, the number of clicks in a GVP, and GVP duration. The exposure periods included: before the vessel was on the range (Before); while the vessel was on the range with the mapping sonar off (Control Survey); while the vessel was on the range and the mapping sonar was on (EM 122 Survey); while multiple acoustic sources were on (Other Active Acoustics); while the vessel was mapping off-range (Immediately After); and while the vessel was off the range and the sonar was off (After). A one-way analysis of variance test was conducted to compare each GVP characteristic across the exposure periods.

The results of both studies indicate that there is no clear change in foraging behavior of beaked whales at the Navy range in response to the EM 122 survey. For three of the four metrics, there was no change in foraging behavior across the exposure periods analyzed (Figure ES-44). The only significant difference observed in any of the GVP characteristics during the 2019 survey was in GVP duration. The GVP duration steadily shortened from the Before period through the Traditional Survey and then increased again After. Overall, there was no widespread change in foraging behavior during the MBES survey that would suggest that the MBES activity impacts foraging at this coarse scale.

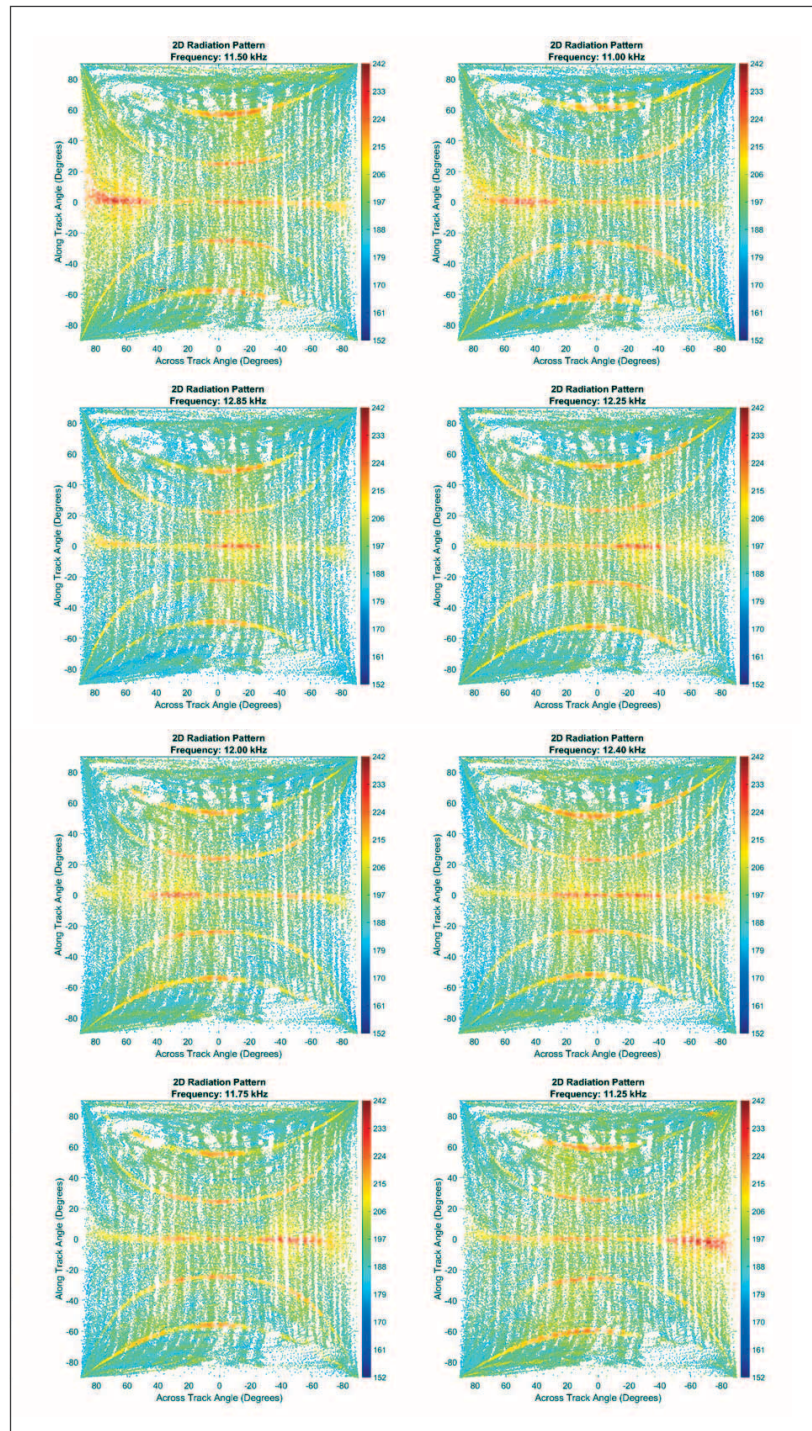

Figure ES-43. Baseline Radiation Pattern test results. Each plot is a top-down, 2D representation of the 3D transmit radiation pattern of a given sector. Data was plotted in the across versus along track and the color corresponds to the equivalent far field source level at 1m as measured by the hydrophone's main beam response and ending after the second lobe generated on the aft end of the vessel. Data is presented in equivalent source level at 1m using an approximate transmission loss correction for the slant range. Black arrows point to the main beam and the additional lobes.

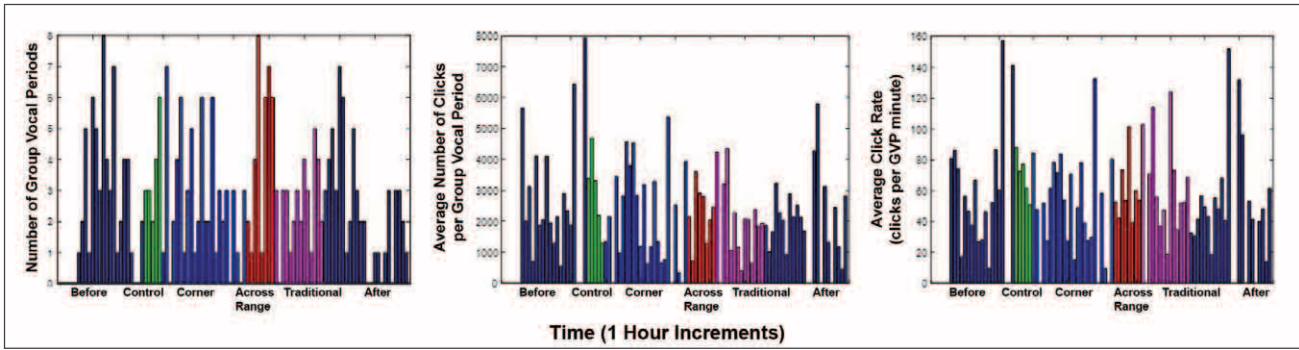

Figure ES-44. Bar graphs of the three GVP characteristics where no differences were found across exposure periods in the 2019 survey. Each graph shows the data binned into hour increments for each of the six exposure periods.

In addition, the animals did not stop foraging and did not leave the range during the MBES survey. This is a significantly different response from that of beaked whales during Navy Mid-Frequency Active Sonar (MFAS) activity on the range, where the same species decreased foraging during MFAS activity (DiMarzio et al. 2019). The results of this study are currently under review for an upcoming *Journal of the Acoustical Society of America's Special Issue on "The Effects of Noise on Aquatic Life."*

An added benefit to the work at the ranges has been the ability to assess the contribution of multibeam sonar to the local acoustic environment (soundscape). Jen Miksis-Olds and graduate student Hilary Kates-Varghese have used differences in frequency correlation plots to successfully separate the contribution of the multibeam signal from background vessel-related noise, a critical component in assessing animal response to MBES surveys (Figure ES-45).

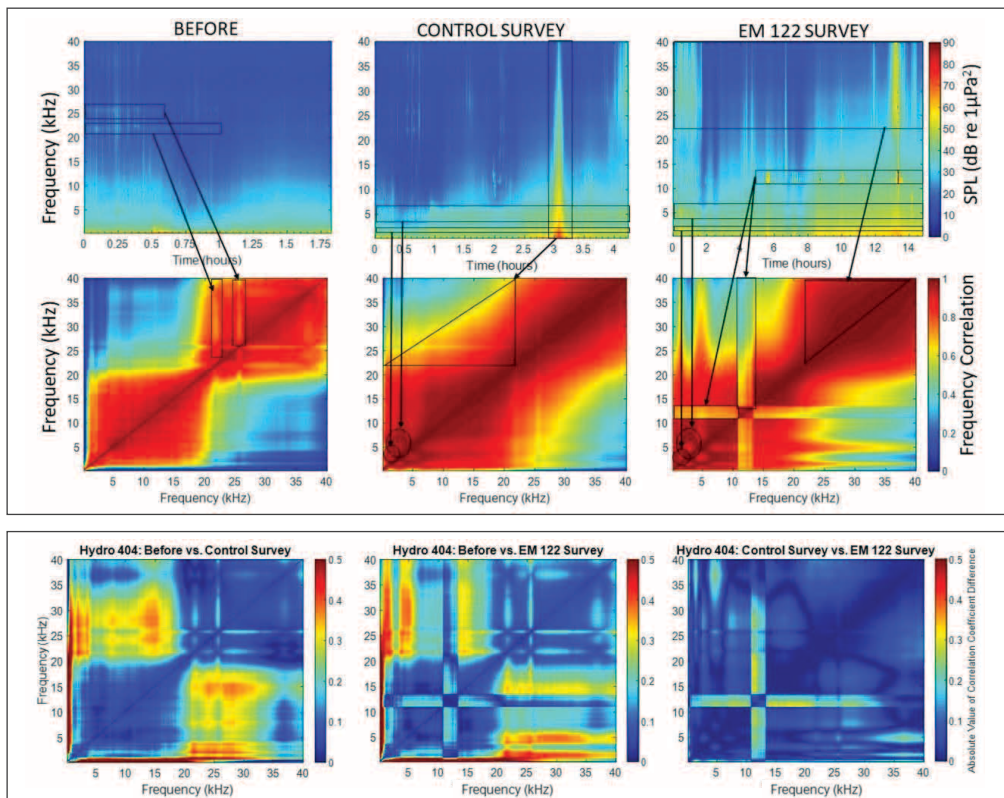

Figure ES-45. Upper Two Frames: Frequency correlation plots for the three time periods on hydrophone 404 (bottom row) in comparison to respective spectrograms (top row). Black boxes and arrows indicate how the content of the two plots relate. Lower Frame: Frequency correlation difference plots, comparing each pair of time periods on hydrophone 404 and showing separation of multibeam signal (right box) from ship-noise (middle box).



## Education and Outreach

In addition to our research efforts, education and outreach are also fundamental components of our program. Our educational objectives are to produce a highly trained cadre of students—critical thinkers able to fill positions in government, industry, and academia, and become leaders in the development of new approaches to ocean mapping. Thirty-seven students were enrolled in the Ocean Mapping program in 2019, including six GEBCO students, one NOAA Corps officer, and three NOAA physical scientists (as part-time Ph.D. students). This year, we graduated two master's and three Ph.D. students, while six GEBCO students received Certificates in Ocean Mapping.

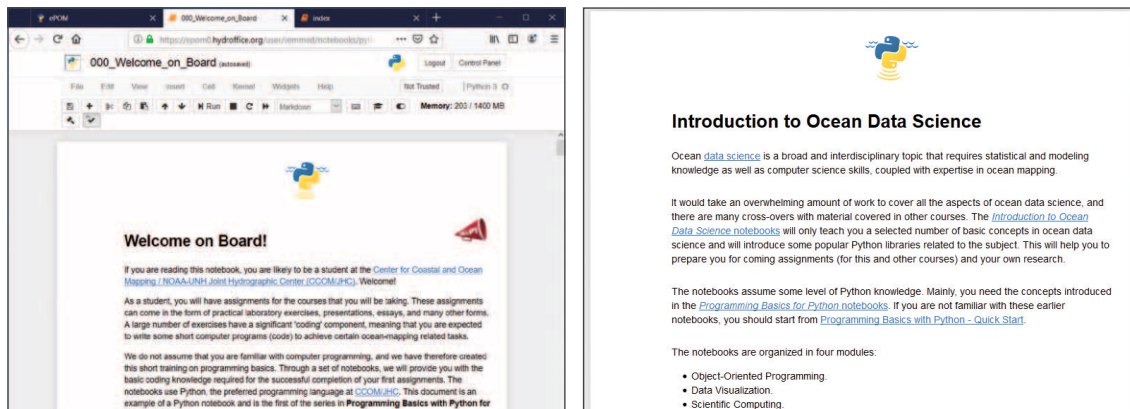

Figure ES-46. Left: The ePOM welcome notebook. Right: Introduction to Ocean Data Science is organized in four modules.

This year, in response to discussions with NOAA OCS, we converted to Python as the preferred programming language for ocean mapping courses and introduced a new E-learning course that will ensure a minimum common level of programming skills among the incoming students (Figure ES-46). In addition, we developed a second Python-based toolkit—Introduction to Ocean Data Science—which provides a series of Python-based lab exercises that are directly tied to our introductory Integrated Seabed Mapping Systems and Geodesy and Positioning for Ocean Mapping courses (Figure ES-46).

Through international competition, the Center has hosted the Nippon Foundation/GEBCO Training Program since 2004. Ninety scholars from 40 nations have completed the Graduate Certificate in Ocean Mapping from the University of New Hampshire as part of this program, and funding has been received for Years 15 and 16. In 2019, a group of alumni from our program beat out twenty other teams to win the \$4M Shell Ocean Discovery XPRIZE. The core GEBCO-NF Alumni Team was made up of fifteen alumni from of the UNH Nippon Foundation/GEBCO Training Program and was advised and mentored by selected GEBCO and industry experts. The prize was awarded at a gala ceremony hosted by the Prince Albert I Foundation on 31 May in Monaco (Figure ES-47).



Figure ES-47. Mr. Unno (Executive Director) and Mao Hasebe (Project Coordinator for the Ocean and Maritime Program and Strategy Team) of the Nippon Foundation with the GEBCO-Nippon Foundation Alumni Team members including Bjørn Jalving and Stian Michael Kristoffersen (Kongsberg Maritime) after the award ceremony in Monaco.





Figure ES-48. Left to right: Mr. Unno, Masanao Sumiyoshi, Sattiabaruth Seeboruth, Prime Minister Shinzo Abe, Mr. Sasakawa, Rochelle Wigley, Karolina Zwolak and Hisataka Hiragochi (Director General of National Ocean Policy Secretariat).

A subset of the team met with Japanese Prime Minister Shinzo Abe on 18 September 2019 to talk about the technology that they developed, and how their model of international scientific cooperation can help to map the gaps that still remain in our understanding of the ocean floor. Also present were Yohei Sasakawa, the Chairman of The Nippon Foundation, which backed the team's entry, and Mitsuyuki Unno,

executive director of the Ocean Affairs division at The Nippon Foundation (Figure ES-48).

We recognize the interest that the public takes in our research and our responsibility to explain the importance of what we do to those who ultimately bear the cost of our work. One of the primary methods of this communication is our website, <http://ccom.unh.edu> (Figure ES-49). In 2019, there were 122,537 views from 32,380 unique visitors to the site from 191 different countries.

We also recognize the importance of engaging young people in our activities to ensure that we will have a steady stream of highly skilled workers in the field. To this end, we have upgraded other aspects of our web presence including a Flickr photostream, Vimeo site, Twitter feed and a Facebook presence. Our Flickr photostream currently has 2,621 photos and our 135 videos were viewed 4,627 times in 2019. Our seminar series (30 seminars featured in 2019) is widely advertised and webcast, allowing NOAA employees and our Industrial Partners around the world to listen and participate. Our seminars are also recorded and uploaded to Vimeo.

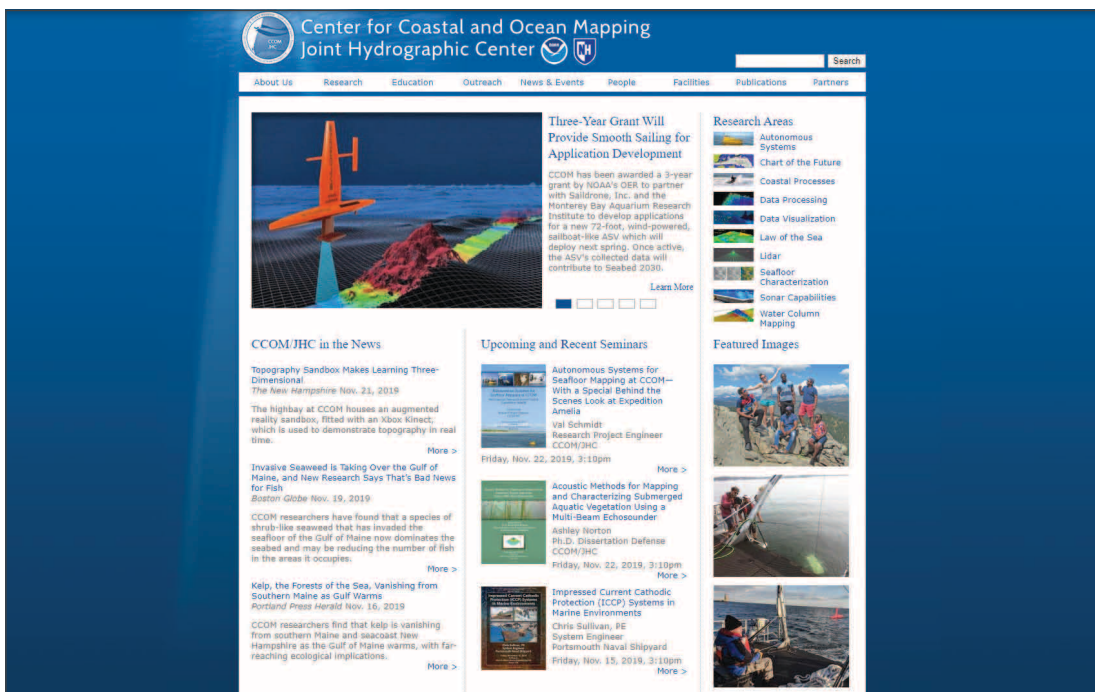

Figure ES-49. The homepage of the Center's website.

Along with our digital and social media presence, we maintain an active “hands-on” outreach program of tours and activities for school children and the general public. Under the supervision of our full-time outreach coordinator, Tara Hicks-Johnson, several large and specialized events were organized by the Center’s outreach team, including numerous SeaPerch ROV events and the annual UNH “Ocean Discovery Days.”

In the SeaPerch ROV events, coordinated with the Portsmouth Naval Shipyard (PNS), students build ROVs and then bring them to the Center to test them in our deep tank as well as tour the Center and the engineering facilities on campus. In its seventh year, fifty teams from New Hampshire, Maine, and Massachusetts schools, after-school programs, and community groups competed in this challenge, using ROVs that they built themselves (Figure ES-50). A SeaPerch is an underwater ROV made from simple materials such as PVC pipe, electric motors, and simple switches. While there is a basic SeaPerch ROV design, the children have the freedom to innovate and create new designs that might be better suited for their specific challenge.

This year’s competition included challenges such as an obstacle course where pilots had to navigate their ROV through five submerged hoops, and a Challenge Course modeled after the Thailand cave rescue, where the ROV had to maneuver through hoops to deliver supplies and collect ROV parts. This year’s winning teams represented the Seacoast at the SeaPerch Finals in College Park, Maryland, which was a wonderful opportunity for our local students to experience competition on a higher level. One of our high school teams came first place for the High School division, and a second high school team came in third for the Mission Course.

The Center hosted the National Marine Educators Association Annual Conference in July, bringing together more than 350 formal and informal marine educators from K-12 schools, public aquariums, non-profit NGOs, and government agencies came together for four days of learning, sharing, and networking.

Ocean Discovery Day is an annual two-day event held at UNH’s Chase Ocean Engineering Laboratory, where the Center is located. On Friday, 18 October we hosted over 1,500 students from school groups and homeschool associations from all over New Hampshire, Maine, and Massachusetts who came to visit our facilities and learn about the exciting research happening here at the Center. Activities

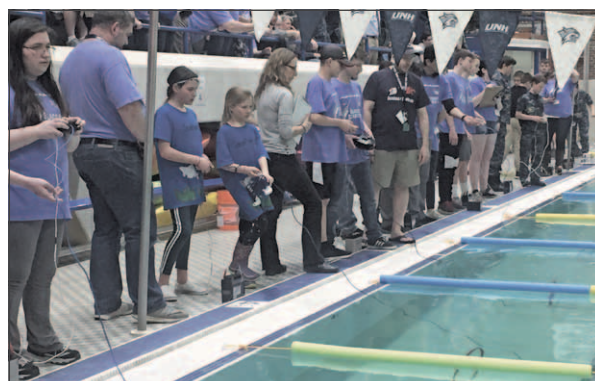
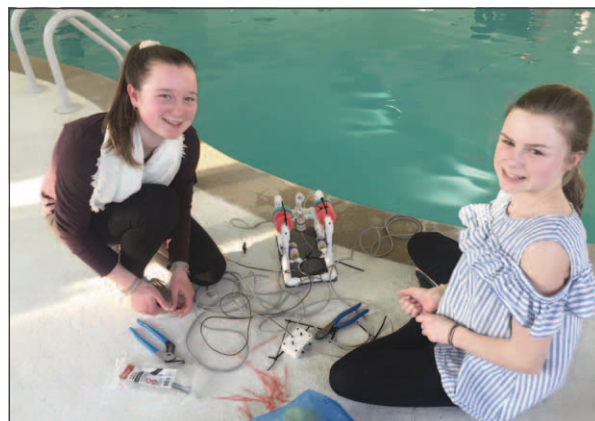

Figure ES-50. Student teams competing at the 2019 SeaPerch Challenge at UNH’s Swasey Pool.

and demonstrations for all ages highlighted research on telepresence, ocean mapping, Autonomous Surface Vehicles (ASVs), ROVs, ocean engineering, coastal ecology, sounds of the ocean, and ocean visualization. The event was then opened to the public on Saturday, 19 October, when 800 more children and adults came to learn about the exciting research at the Center (Figure ES-51).

Center activities have also been featured in many international, national, and local media outlets this year including: the BBC, *Wired*, *Forbes*, *Science*, *Popular Mechancis*, *Bloomberg Businessweek*, *Hydro International*, *NewsWise*, *The Engineer*, *Business Telegraph*, *Digital Trends*, *Yale Environment 360*, *Philanthropy News Digest*, *Marine Technology News*, *National Marine Sanctuaries News*, *Arctic Today*, *Daily Beast*, *Tech Crunch*, *Ars Technica*, *Hakai Magazine*, *Union Leader*, *Foster’s Daily Democrat*, *Concord Monitor*, *Seacoast Online*, *NH Business Review*, *Hellenic Shipping News*, *City Press*, *Science Daily*, *Boston Globe*, *Portland Press Herald*, *Maritime Executive*, *Workboat*, *Svierges Radio*, *Kristinstad Bladet*, *Alpena News*, *News 18*, *NHPR*, *WCAX*, and *Boston News 25*.



The highlights presented here represent only a fraction of the activities of the Joint Hydrographic Center in 2019. More detailed discussions of these and other activities, as well as a complete list of Center publications can be found in the full progress reports available at <http://com.unh.edu/reports>.



Figure ES-51. More than 1,500 students visited the Center during Ocean Discovery Day followed by another 800 visitors at the open house on the following day.



On 4 June 1999, the Administrator of NOAA and the President of the University of New Hampshire signed a memorandum of understanding that established a Joint Hydrographic Center (JHC) at the University of New Hampshire. On 1 July 1999, a cooperative agreement was awarded to the University of New Hampshire that provided the initial funding for the establishment of the Joint Hydrographic Center. This Center, the first of its kind to be established in the United States, was formed as a national resource for the advancement of research and education in the hydrographic and ocean-mapping sciences. In the broadest sense, the activities of the Center are focused on two major themes: a research theme aimed at the development and evaluation of a wide range of state-of-the-art hydrographic and ocean-mapping technologies and applications, and an educational theme aimed at the establishment of a learning center that promotes and fosters the education of a new generation of hydrographers and ocean-mapping scientists to meet the growing needs of both government agencies and the private sector. In concert with the Joint Hydrographic Center, the Center for Coastal and Ocean Mapping was also formed in order to provide a mechanism whereby a broader base of support (from the private sector and other government agencies) could be established for ocean-mapping activities.

The Joint Hydrographic Center was funded by annual cooperative agreements from July 1999 until 31 December 2005. In 2005, a five-year cooperative agreement was awarded with an ending date of 31 December 2010. In January 2010, a Federal Funding Opportunity was announced for the continuation of a Joint Hydrographic Center beyond 2010. After a national competition, the University of New Hampshire was selected as the recipient of a five-year award, funding the Center for the period of 1 July 2010 until December 2015. In March 2016, a Federal Funding Opportunity was announced for the continuation of a Joint Hydrographic Center beyond 2015. Again, after a national competition, the University of New Hampshire was selected as the recipient of a five-year award, funding the Center for the period of 1 January 2016 until 31 December 2020. This report represents the progress on the fourth year of effort on this latest grant (NA15NOS4000200).

This report is the twenty-fifth in a series of what were, until December 2002, semi-annual progress reports. Since December 2002, the written reports have been produced annually. Copies of previous reports (from the last grant—NA10NOS4000073—and all previous grants to the Joint Hydrographic Center) and more in-depth information about the Center can be found on the Center's website, <http://www.ccom.unh.edu>. More detailed descriptions of many of the research efforts described herein can be found in the individual progress reports of Center researchers, which are available on request.

## Infrastructure

### Personnel

Over the past 19 years, the Center has grown from an original complement of 18 people to more than 90 faculty, staff, and students. Our faculty and staff have been remarkably stable over the years, but as with any large organization, inevitably, there are changes. In 2019 we saw several of these changes. After working with us as a Post-doc and then a Research Scientist, **Firat Eren** returned to his native Turkey to pursue a job in the industrial sector (and get married) and after 13 years of tremendous service to the Center, **Linda Prescott** retired from her administrative position. Replacing Linda, **Wendy Monroe** was promoted to Senior Program Support Assistant and new hire **Kris Tonkin** has come on board as a Program Support Assistant. Finally, **Kristen Mello**, **Michael Sleep**, and **Michael Smith** have joined our staff—Kristen as a Project Research Specialist, Michael Sleep in the position of IT Systems Administrator, and Michael Smith as a Research Engineer.

## Faculty

**Thomas Butkiewicz** received a Bachelor of Science degree in computer science in 2005 from Ithaca College where he focused on computer graphics and virtual reality research. During his graduate studies at The University of North Carolina at Charlotte, he designed and developed new interactive geospatial visualization techniques, receiving a master's degree in computer science in 2007 and a Ph.D. in computer science in 2010. After a year as a research scientist at the Charlotte Visualization Center, he joined the Center as a post-doctoral research fellow in 2011. In 2012, he joined the faculty as a research assistant professor. Tom specializes in creating highly inter-active visualizations that allow users to perform complex visual analysis on geospatial datasets through unique, intuitive exploratory techniques. His research interests also include multi-touch and natural interfaces, virtual reality, stereoscopic displays, and image processing/computer vision. His current research projects include visual analysis of 4D dynamic ocean simulations, using Microsoft's Kinect device to enhance multi-touch screens and provide new interaction methods, multi-touch gesture research, and developing new interface approaches for sonar data cleaning.

**Brian Calder** graduated with an M.Eng. (Merit) and a Ph.D. in electrical and electronic engineering in 1994 and 1997, respectively, from Heriot-Watt University in Scotland. His doctoral research was in Bayesian statistical methods applied to processing of sidescan sonar and other data sources, and his post-doctoral research included the investigation of high-resolution seismic reconstruction, infrared data simulation, high-resolution acoustic propagation modeling and real-time assessment of pebble size distributions for mining potential assessment. Brian joined the Center as a founding member in 2000, where his research has focused mainly on understanding, utilizing and portraying the uncertainty inherent in bathymetric data, and in efficient semi-automatic processing of high-density multibeam echosounder data. He is a research professor and associate director of the Center, the chair of the Open Navigation Surface Working Group, and a past associate editor of *IEEE Journal of Oceanic Engineering*.

**Jenn Dijkstra** received her Ph.D. in zoology in 2007 at the University of New Hampshire, has a B.A. from the University of New Brunswick (Canada), and an M.S. in marine biology from the University of Bremen (Germany). She has conducted research in a variety of geographical areas and habitats, from polar to tropical and from intertidal to deep-water. Her research incorporates observation and experimental approaches to address questions centered around the ecological causes and consequences of human-mediated effects on benthic and coastal communities. Her research at the Center focuses on the use of remote sensing (video and multibeam) to detect and characterize benthic communities.

**Semme Dijkstra** is a hydrographer from the Netherlands with hydrographic experience in both the Dutch Navy and industry. He completed his Ph.D. at the University of New Brunswick, Canada, where his thesis work involved artifact removal from multibeam-sonar data and development of an echosounder processing and sediment classification system. From 1996 to 1999, Semme worked at the Alfred Wegner Institute in Germany where he was in charge of their multibeam echosounder data acquisition and processing. Semme's current research focuses on applications of single-beam sonars for seafloor characterization, small object detection and fisheries habitat mapping. In 2008, Semme was appointed a full-time instructor and took a much larger role in evaluating the overall Center curriculum, the development of courses and teaching. In 2016, the University re-classified Semme's position to Research Scientist, but he maintains his active role in teaching and curriculum development.

**Jim Gardner** is a marine geologist focused on seafloor mapping, marine sedimentology, and paleoceanography. He received his Ph.D. in marine geology from the Lamont Doherty Earth Observatory of Columbia University in 1973. He worked for 30 years with the Branch of Pacific Marine Geology at the U.S. Geological Survey in Menlo Park, CA where he studied a wide variety of marine sedimentological and paleoceanographic problems in the Bering Sea, North and South Pacific Ocean, northeast Atlantic Ocean, Gulf of Mexico, Caribbean and Mediterranean Seas, and the Coral Sea. He conceived, organized, and directed the eight-year EEZ-SCAN mapping of the U.S. Exclusive Economic Zone using GLORIA long-range sidescan sonar in the 1980s; participated in four Deep Sea Drilling Project cruises, one as co-chief scientist; participated in more than 50 research cruises, and was Chief

of Pacific Seafloor Mapping from 1995 to 2003, a project that used high-resolution multibeam echosounders to map portions of the U.S. continental shelves and margins. He also mapped Lake Tahoe in California and Crater Lake in Oregon. Jim was the first USGS Mendenhall Lecturer, received the Department of Interior Meritorious Service Award and received two USGS Shoemaker Awards. He has published more than 200 scientific papers and given an untold number of talks and presentations all over the world. Jim retired from the U.S. Geological Survey in 2003 to join the Center.

Jim was an adjunct professor at the Center from its inception until he moved to UNH in 2003 when he became a research professor affiliated with the Earth Science Dept. At the Center, Jim is in charge of all non-Arctic U.S. Law of the Sea bathymetry mapping cruises and is involved in research methods to extract meaningful geological information from multibeam acoustic backscatter through ground truth and advanced image analysis methods. Jim was awarded the 2012 Francis P. Shepard Medal for Sustained Excellence in Marine Geology by the SEPM Society of Sedimentary Geology. Jim has taught Geological Oceanography (ESCI 759/859) and the Geological Oceanography module of Fundamentals of Ocean Mapping (ESCI 874/OE 874.01). In 2013, Jim reduced his effort to half-time.

**John Hughes Clarke** is a professor jointly appointed in the departments of Earth Sciences and Mechanical Engineering. For 15 years before joining the Center, John held the Chair in Ocean Mapping at the University of New Brunswick in Canada where he was a Professor in the Department of Geodesy and Geomatics Engineering. During that period, he also ran the scientific seabed mapping program on board the CCGS *Amundsen* undertaking seabed surveys of the Canadian Arctic Archipelago. As a complement to his research and teaching, he has acted as a consultant, formally assessing the capability of the hydrographic survey vessels of the New Zealand, Australian, British and Dutch Navies as well as the U.S. Naval Oceanographic Office TAGS fleet. For the past 21 years, John, together with Larry Mayer, Tom Weber, and Dave Wells, has delivered the Multibeam Training Course that is presented globally three times per year. This is the world's leading training course in seabed survey and is widely attended by international government and commercial offshore survey personnel as well as academics. John was formally trained in geology and oceanography in the UK and Canada (Oxford, Southampton, and Dalhousie). He has spent the last 27 years, however, focusing on ocean mapping methods. His underlying interest lies in resolving seabed sediment transport mechanisms.

**Jim Irish** received his Ph.D. from Scripps Institution of Oceanography in 1971 and worked many years at the Woods Hole Oceanographic Institution where he is still an Oceanographer Emeritus. He is currently a research professor of ocean engineering at UNH and has also joined the Center team. Jim's research focuses on ocean instruments, their calibration, response and the methodology of their use; buoys, moorings and modeling of moored observing systems; physical oceanography of the coastal ocean, including waves, tides, currents and water-mass property observations and analysis; and acoustic instrumentation for bottom sediment and bedload transport, for remote observations of sediment and for fish surveys.

**Tom Lippmann** is an associate professor with affiliation in the Department of Earth Sciences, Marine Program, and Ocean Engineering Graduate Program, and is currently the director of the Oceanography Graduate Program. He received a B.A. in mathematics and biology from Linfield College (1985), and an M.S. (1989) and Ph.D. (1992) in oceanography at Oregon State University. His dissertation research conducted within the Geological Oceanography Department was on shallow water physical oceanography and large-scale coastal behavior. He went on to do a post-doc at the Naval Postgraduate School (1992-1995) in physical oceanography. He worked as a research oceanographer at Scripps Institution of Oceanography (1995-2003) in the Center for Coastal Studies. He was then a research scientist at Ohio State University (1999-2008) jointly in the Byrd Polar Research Center and the Department of Civil and Environmental Engineering & Geodetic Science. Tom's research is focused on shallow water oceanography, hydrography, and bathymetric evolution in coastal waters spanning the inner continental shelf, surf zone, and inlet environments. Research questions are collaboratively addressed with a combination of experimental, theoretical, and numerical approaches. He has participated in 20 nearshore field experiments and spent more than two years in the field.



**Anthony P. Lyons** received a B.S. degree (*summa cum laude*) in physics from the Henderson State University, Arkadelphia, AR, in 1988 and M.S. and Ph.D. degrees in oceanography from Texas A&M University, College Station, TX, in 1991 and 1995, respectively. He was a scientist at the SAACLANT Undersea Research Centre, La Spezia, Italy, from 1995 to 2000, where he was involved in a variety of projects in the area of environmental acoustics. Tony was awarded, with the recommendation of the Acoustical Society of America, the Institute of Acoustics' (U.K.) A.B. Wood Medal in 2003. He is a Fellow of the Acoustical Society of America and a member of the IEEE Oceanic Engineering Society. He is also currently an Associate Editor for the *Journal of the Acoustical Society of America* and is on the Editorial Board for the international journal *Methods in Oceanography*. Tony conducts research in the field of underwater acoustics and acoustical oceanography. His current areas of interest include high-frequency acoustic propagation and scattering in the ocean environment, acoustic characterization of the seafloor, and quantitative studies using synthetic aperture sonar.

**Giuseppe Masetti** received an M.Eng. in ocean engineering (ocean mapping option) from the University of New Hampshire in 2012, and a master's degree in marine geomatics (with honors) and a Ph.D. degree in system monitoring and environmental risk management from the University of Genoa, Italy, in 2008 and 2013, respectively. In addition, he graduated (with honors) in Political Sciences from the University of Pisa, Italy, in 2003 and in Diplomatic and International Sciences from the University of Trieste, Italy, in 2004. Giuseppe achieved the FIG/IHO Category A certification in 2010, and is a member of IEEE and The Hydrographic Society of America. He served with the Italian Navy from 1999 and has been Operations Officer aboard the hydrographic vessels ITN *Aretusa* and ITN *Magnaghi*. From August 2013, he was a Tyco Post-Doctoral Fellow with the Center, where he focused on signal processing for marine target detection. He joined the faculty as a Research Assistant Professor in January 2016.

**Larry Mayer** is the founding Director of the Center for Coastal and Ocean Mapping and Co-Director of the Joint Hydrographic Center. Larry's faculty position is split between the Ocean Engineering and Earth Science Departments. His Ph.D. is from the Scripps Institution of Oceanography (1979), and he has a background in marine geology and geophysics with an emphasis on seafloor mapping, innovative use of visualization techniques, and the remote identification of seafloor properties from acoustic data. Before coming to New Hampshire, he was the NSERC Chair of Ocean Mapping at the University of New Brunswick where he led a team that developed a worldwide reputation for innovative approaches to ocean mapping problems.

**Jennifer Miksis-Olds** is the Associate Director of Research and Research Professor in the School of Marine Science and Ocean Engineering and the Director of the Center for Acoustics Research and Education at the University of New Hampshire, also holding a research position in the Center for Coastal and Ocean Mapping. Jenn is the University Member Representative on the Board of Trustees of the Consortium for Ocean Leadership. She is a member of the Scientific Committee of the International Quiet Ocean Experiment Program and serves as a Scientific Advisor to the Sound and Marine Life Joint Industry Program (International Oil & Gas Producers) which is devoted to the study of effects of sound on marine organisms. Jenn was the recipient of an Office of Naval Research Young Investigator Program award in 2011 and the Presidential Early Career Award in Science and Engineering in 2013. She is also a newly elected Fellow in the Acoustical Society of America. Jenn received her A.B. *cum laude* in biology from Harvard University, her M.S. in biology from the University of Massachusetts Dartmouth; she was a guest student at Woods Hole Oceanographic Institution, and then received her Ph.D. in Biological Oceanography from the University of Rhode Island.

**Yuri Rzhanov**, a Research Professor, has a Ph.D. in physics and mathematics from the Russian Academy of Sciences. He completed his thesis on nonlinear phenomena in solid-state semiconductors in 1983. Since joining the Center in 2000, he has worked on a number of signal processing problems, including construction of large-scale mosaics from underwater imagery, automatic segmentation of acoustic backscatter mosaics, and accurate measurements of underwater objects from stereo imagery. His research interests include the development of algorithms and their implementation in software for 3D reconstruction of underwater scenes, and automatic detection and abundance estimation of various marine species from imagery acquired from ROVs, AUVs, and aerial platforms.

**Larry Ward** has an M.S. (1974) and a Ph. D. (1978) from the University of South Carolina in Geology. He has more than 30 years' experience conducting research in shallow water marine systems. His primary interests include estuarine, coastal, and inner shelf morphology and sedimentology with his most recent research focusing on sea-floor characterization and the sedimentology, stratigraphy, and Holocene evolution of nearshore marine systems. Larry is currently teaching a course in Nearshore Processes and a Geological Oceanography module.

**Colin Ware** received a Ph.D. in psychology from the University of Toronto in 1980 and an M.Math in computer science from the University of Waterloo in 1982. He is professor (emeritus) of computer science and the Director of the Data Visualization Research Lab at the Center for Coastal and Ocean Mapping. He is the author of *Visual Thinking for Design* (2008) which discusses the science of visualization and has published more than 140 research articles on subject of data visualization. His other book, *Information Visualization: Perception for Design* (4<sup>th</sup> Edition 2020) has become the standard reference in the field. Fledermaus, a visualization package initially developed by him and his students, is now the leading 3D visualization package used in ocean mapping applications. He currently works on methods and tools for visualizing ocean and littoral data, including the representation of wind, wave and current information on electronic chart displays, the visualization of the state of global seafloor mapping to support the Seabed 2030 project, and methods for improving the processing of multibeam sonar data.

**Tom Weber** received his Ph.D. in acoustics at The Pennsylvania State University in 2006 and has B.S. (1997) and M.S. (2000) degrees in ocean engineering from the University of Rhode Island. After joining the Center in 2006, he joined the UNH Mechanical Engineering Department as an assistant professor in 2012. Tom conducts research in the field of underwater acoustics and acoustical oceanography. His specific areas of interest include acoustic propagation and scattering in fluids containing gas bubbles, the application of acoustic technologies to fisheries science, high-frequency acoustic characterization of the seafloor, and sonar engineering.

## Research Scientists and Staff

**Roland Arsenault** joined the Center in 2000 after receiving his Bachelor's degree in Computer Science and working as a research assistant with the Human Computer Interaction Lab at the Department of Computer Science at the University of New Brunswick. A longtime member of the Center's Data Visualization Research Lab, Roland combines his expertise with interactive 3D graphics with his experience working with various mapping-related technologies to help provide a unique perspective on some of the challenges undertaken at the Center. With the Center's addition of Autonomous Surface Vehicles (ASVs), Arsenault has become the ASV lab's chief software engineer developing a cross-platform ocean mapping focused framework for the Center's ASV fleet.

**KG Fairbairn** holds a B.A. in geography from UC Santa Barbara and an M.S. in remote sensing intelligence from the Naval Postgraduate School. He has worked extensively at sea as a researcher, marine technician, captain, and research diver. He most recently worked as the oceanographic specialist aboard the University of Delaware's R/V *Hugh R. Sharp*. At UNH, KG works as an engineer on the autonomous surface vehicle project and will assist with the multibeam advisory committee duties.

**Will Fessenden** is the Center's Systems Manager. He has provided workstation, server, and backup support for the Center since 2005, and has over 15 years of experience in information technology. He previously worked for the University of New Hampshire's Information Technology Department in both retail and support capacities. In addition to holding industry certifications for Microsoft, Apple, Dell and other platforms, Fessenden has a B.A. in Political Science from the University of New Hampshire.

**Tara Hicks Johnson** has a B.S. in geophysics from the University of Western Ontario, and an M.S. in geology and geophysics from the University of Hawaii at Manoa where she studied meteorites. In June 2011, Tara moved to New Hampshire from Honolulu, Hawaii, where she was the Outreach Specialist for the School of Ocean and Earth Science and Technology at the University of Hawaii at Manoa. While there, she organized educational and community events for the school, including the biennial Open House event, and ran the Hawaii Ocean Sciences



Bowl, the Aloha Bowl. She also handled media relations for the School and coordinated television production projects. Tara also worked with the Bishop Museum in Honolulu developing science exhibits, and at the Canadian Broadcasting Corporation in Toronto (where she was born and raised).

**Tianhang Hou** was a research associate with the University of New Brunswick Ocean Mapping for six years before coming to UNH. He has significant experience with the UNB/OMG multibeam processing tools and has taken part in several offshore surveys. He is currently working with Briana Sullivan on the Chart of the Future project.

**Jon Hunt**, a UNH alumnus who studied economics and oceanography while a student at the university, is now a research technician at the Center. Under the supervision of Tom Lippmann, Jon has built a survey vessel which is capable of undertaking both multibeam sonar surveys and the measurements of currents. Hunt is a certified research scuba diver and has been a part of many field work projects for the Center.

**Kevin Jerram** completed his M.S. in ocean engineering (ocean mapping option) in 2014 through the UNH Center for Coastal and Ocean Mapping, where his research focused on detection and characterization of marine gas seeps using a split-beam scientific echosounder. He has participated in seafloor and midwater mapping expeditions throughout the Atlantic, Pacific, and Arctic Oceans in support of Center projects, and works with the NSF-funded Multibeam Advisory Committee to enhance mapping data quality across the U.S. academic fleet. Before joining the Center, he received a B.S. in mechanical engineering from UNH and worked in engineering positions for Shoals Marine Laboratory and Ocean Classroom Foundation.

**Paul Johnson** has an M.S. in geology and geophysics from the University of Hawaii at Manoa where he studied the tectonics and kinematics of the fastest spreading section of the East Pacific Rise. Since finishing his master's, he has spent time in the remote sensing industry processing, managing, and visualizing hyperspectral data associated with coral reefs, forestry, and research applications. More recently, he was the interim director of the Hawaii Mapping Research Group at the University of Hawaii where he specialized in the acquisition, processing, and visualization of data from both multibeam mapping systems and towed near bottom mapping systems. Paul came to UNH in June of 2011 as the Center's data manager. When not working on data-related issues for the Center, he is aiding in the support of multibeam acquisition for the U.S. Academic Research Fleet through the National Science Foundation's Multibeam Advisory Committee.

**Christos Kastrisios** graduated from the Hellenic Naval Academy (HNA) in 2001 as an Ensign of the Hellenic Navy Fleet with a B.Sc. in naval science. After his graduation, he served aboard frigate HS *Aegean* and submarines HS *Protefs* and HS *Poseidon*, mostly as the Navigator and Sonar Officer, and participated in several deployments at sea. In 2008 he was appointed to the Hellenic Navy Hydrographic Service (HNHS) where he served in various positions including that of deputy chief of the Hydrography Division and the Head of the Geospatial Policy Office. He also represented his country at international committees and working groups. In 2013, he received a master's degree in GIS from the University of Maryland at College Park; in 2015 he graduated from the Hellenic Naval War College; and in 2017 he was awarded a Ph.D. in cartography from the National Technical University of Athens (NTUA) for his work on the scientific aspects of the Law of the Sea Convention. From 2014 to 2017, he worked as a part-time lecturer in GIS and cartography at the HNA and NTUA. In September 2017, he started employment at the Center as a post-doctoral researcher focusing on data generalization, chart adequacy, and computer-assisted nautical cartography. He joined the Center's full-time staff as a research scientist in 2018.

**Tomer Ketter** is the former hydrographer of the National Oceanographic Institute of Israel. He spent the last three years as Chief Surveyor aboard the R/V *Bat-Galim* and led the mapping of the Israel EEZ. Prior to joining the Center, Ketter was part of the GNFA team on the Ocean Discovery XPrize contest. He holds a B.Sc. in Marine and Environmental Sciences and an M.Sc. in Marine Geosciences, as well as IHO/FIG/ICA Category A Hydrography certification from the GEBCO-Nippon Foundation ocean mapping program at JHC/CCOM. He now contributes to the Seabed 2030 network and to the Multibeam Advisory Committee at CCOM/UNH.

**Carlo Lanzoni** received a master's degree in ocean engineering from the University of New Hampshire. His master's research was the design of a methodology for field calibration of multibeam echo sounders using a

split-beam sonar system and a standard target. He also has an M.S. and a B.S. in electrical engineering from the University of New Hampshire. Lanzoni has worked with different calibration methodologies applied to a variety of sonar systems. He is responsible for the operation, maintenance, and development of test equipment used in acoustic calibrations of echo sounders at the acoustic tank in the Chase Ocean Engineering Lab. His research focuses on the field calibration methodology for multibeam echo sounders.

**Kim Lowell** is a research scientist at the Center, as well as an adjunct professor in analytics and data science, and an affiliate research professor in the Earth Systems Research Center. His primary focus at the Center is the application of machine learning, deep learning, and other data analytics techniques to improve the accuracy of bathymetric charts. He has considerable experience in the analysis of geospatial information to address land management issues using GIS, spatial statistics, and optical, radar, and lidar imagery while also accounting for uncertainties inherent in those data. Prior to joining the Center, he was a program manager for a nationwide (Australian) collaborative geospatial research consortium whose members included private companies, government agencies, and universities. He also has been the director of a group of hydrologically-based landscape modelers for a state Department of Primary Industries (Victoria, Australia). Prior to that, he was a tenured full professor in the Faculty of Forestry and Geomatic Engineering at Université Laval (Québec, Canada). Lowell has an M.Sc. (University of Vermont, USA) and a Ph.D. (Canterbury University, New Zealand) in forest biometrics, and an M.Sc. in data science and analytics (University of New Hampshire).

**Zachary McAvoy** received a B.S. in geology from the University of New Hampshire in 2011. His background is in geochemistry, geology, and GIS. Since graduating, he has worked on various environmental and geoscience-related projects for the Earths Systems Research Center and Ocean Process Analysis Laboratory at UNH; as well as the New Hampshire DOT and Geological Survey. Zach is currently a research technician working for Dr. Larry Ward. As part of a BOEM beach nourishment study, he is using geologic and geospatial datasets for synthesis in GIS and mapping the geomorphology of the New Hampshire inner continental shelf.

**Andy McLeod** received his B.S. in ocean studies from Maine Maritime Academy in 1998. His duties at the Center include supporting autonomous vehicle projects from conception and pre-production through to completion, providing technical support, managing project budgets, overseeing maintenance and operations, completion of documentation, producing test plans and reports, preparing contract documentation for procurement services and materials, and carrying out effective liaison with research partners.

**Kristen Mello** is a UNH alumna with a B.Sc. in zoology. She obtained a Rutman Fellowship from the Shoals Marine Laboratory to study invasive macroalgae species at the Isles of the Shoals. Soon after completing her fellowship, she began working as a research technician at the Center focusing on mapping temporal and spatial distribution of macroalgae and fine-scale distribution of deep sea coral habitats in the Northwest Atlantic Ocean. As a project research specialist, she continues to work on various topics such as invasive macroalgae, and fine-scale habitat mapping in local subtidal, tropical subtidal, and deep sea environments. Kristen specializes in all SCUBA diving-related tasks including planning, executing, and analyzing data collected during dives

**Colleen Mitchell** earned a B.A. in English from Nyack College in Nyack, NY and a master's in education from the State University of New York at Plattsburgh. She began working for the Environmental Research Group (ERG) at UNH in 1999. In 2009, Mitchell joined the Center as a graphic designer where she is responsible for the Center's graphic identity and creates ways to visually communicate the Center's message in print and digital media. In addition, Colleen manages the Center's website and develops content for the Center's social media platforms.

**Matthew Rowell** joined Center staff in 2017 as the captain of the R/V *Gulf Surveyor*. Capt. Rowell first came to the University of New Hampshire in 2011 to pursue a graduate degree in mechanical engineering with a focus on hydrokinetic energy. Upon completion of his master's degree, he filled a research project engineering position at UNH in the Ocean Engineering Department and, in that capacity, was instrumental in the design and construction of the R/V *Gulf Surveyor*. Prior to UNH, Capt. Rowell studied mechanical engineering at Clarkson University and spent eight years as an officer in the U.S. Navy studying surface warfare and nuclear power.

**Val Schmidt** received his bachelor's degree in physics from the University of the South, Sewanee, TN in 1994. During his junior undergraduate year, he joined the Navy and served as an officer in the submarine fleet aboard the USS *Hawkbill* from 1994 to 1999. In 1998 and 1999, the USS *Hawkbill* participated in two National Science Foundation sponsored "SCICEX" missions to conduct seafloor mapping from the submarine under the Arctic ice sheet. Schmidt served as Sonar and Science Liaison Officer during these missions. He left the Navy in 1999 and worked for Qwest Communications as a telecommunications and Voice over IP engineer from 2000 to 2002. Schmidt began work in 2002 as a research engineer for the Lamont Doherty Earth Observatory of Columbia University where he provided science-engineering support both on campus and to several research vessels in the U.S. academic research fleet. He acted as a technical lead aboard the U.S. Coast Guard Icebreaker *Healy* for several summer cruises in this role. Schmidt completed his master's degree in ocean engineering in 2008 at the Center. His thesis involved development of an underwater acoustic positioning system for whales that had been tagged with an acoustic recording sensor package. He continues to work as an engineer for the Center where his research focuses on hydrographic applications of ASVs, AUVs, and Phase Measuring Bathymetric sonars.

**Erin Selner** has worked in research support roles for UNH since 2000. Her background includes research administration and accounting, as well as conference administration and project support. She received a B.A. from the College of William and Mary in Virginia.

**Michael Sleep** is a systems administrator with nine years of IT experience. His focus is on providing automation and wrangling linux-based systems, network monitoring, and providing support to the Center's faculty, staff, and students. He is working towards becoming a certified Red Hat Linux systems administrator.

**Michael Smith** joined the Center in 2016 as a master's student in ocean engineering/ocean mapping where his master's thesis focused on quantifying the radiation patterns of deep water multibeam echosounders for calibration and impact assessment. Prior to joining the Center, Michael had graduated the University of Rhode Island's International Engineering Program (IEP) with a B.S. in ocean engineering and a B.A. in Spanish. His time in IEP placed him in internships aboard the E/V *Nautilus* and the University of Las Palmas AUV team. At the Center, Michael is involved with a number of projects related to deep and shallow water multibeam echosounders. His work includes the development of open-source software solutions for hydrographic surveying and MBES backscatter processing. He continues to expand his thesis work on deep-water multibeam sound source verification and assessment. Michael has also worked on shallow water multibeam echosounder calibration methodologies, both in the acoustic tank and in field. Michael greatly enjoys time out at sea, having participated in a number of research and mapping cruises.

**Briana Sullivan** received a B.S. in computer science from UMASS, Lowell and an M.S. in computer science from UNH, under the supervision of Dr. Colin Ware. Her master's thesis involved linking audio and visual information in a virtual underwater kiosk display that resulted in an interactive museum exhibit at the Seacoast Science Center. Sullivan was hired in July 2005 as a research scientist for the Center. She works on the Chart of the Future project which involves things such as the Local Notice to Mariners, ship sensors, the CoastPilot, and other marine-related topics. Her focus is on web technologies and mobile environments.

**Dan Tauriello** graduated from UNH in 2014 with a B.S in marine biology and a minor in ocean engineering. At the Center, he wears many hats including graduate student, IT technician, and first mate aboard the Center's research vessels. As a master's student in Earth Science/Ocean Mapping, he is focused on hardware testing and development related to system design for a trusted method of collecting crowdsourced bathymetric data. In the past, he has served as an Explorer in Training aboard NOAA Ship *Okeanos Explorer*, and ran a variety of experimental aquaculture projects in the Portsmouth Harbor area.

**Emily Terry** joined the Center as Relief Captain in 2009, and was promoted to research vessel captain in 2014. She came to the Center from the NOAA Ship *Fairweather* where she worked for three years as a member of the deck department, separating from the ship as a Seaman Surveyor. Prior to working for NOAA, she spent five years working aboard traditional sailing vessels. Capt. Terry holds a USCG 100 ton near coastal license.



**Rochelle Wigley** has a mixed hard rock/soft rock background with an M.Sc. in igneous geochemistry (focusing on dolerite dyke swarms) and a Ph.D. in sedimentology/sediment chemistry, where she integrated geochemistry and geochronology into marine sequence stratigraphic studies of a condensed sediment record in order to improve the understanding of continental shelf evolution along the western margin of southern Africa. Phosphorites and glauconite have remained as a research interest where these marine authigenic minerals are increasingly the focus of offshore mineral exploration programs. She was awarded a Graduate Certificate in Ocean Mapping from UNH in 2008. Rochelle concentrated largely on understanding the needs and requirements of all end-users within the South African marine sectors on her return home, as she developed a plan for a national offshore mapping program from 2009 through 2012. As project director of the GEBCO Nippon Foundation Indian Ocean Project, she is involved in the development of an updated bathymetric grid for the Indian Ocean and management of a project working to train other Nippon Foundation GEBCO scholars. In 2014, Rochelle took on the responsibility of the director of the Nippon Foundation GEBCO training program at the Center.

In addition to the academic, research and technical staff, our administrative support staff, **Wendy Monroe, Renee Blinn,** and **Kris Tonkin** ensure the smooth running of the organization.

## NOAA Employees

*NOAA has demonstrated its commitment to the Center by assigning fourteen NOAA employees (or contractors) to the Center.*

**Capt. Andrew Armstrong**, founding co-director of the JHC, retired as an officer in the National Oceanic and Atmospheric Administration Commissioned Officer Corps in 2001 and is now assigned to the Center as a civilian NOAA employee. Capt. Armstrong has specialized in hydrographic surveying and served on several NOAA hydrographic ships, including the NOAA Ship *Whiting* where he was Commanding Officer and Chief Hydrographer. Before his appointment as Co-Director of the NOAA/UNH Joint Hydrographic Center, Capt. Armstrong was the Chief of NOAA's Hydrographic Surveys Division, directing all of the agency's hydrographic survey activities. Capt. Armstrong has a B.S. in geology from Tulane University and an M.S. in technical management from the Johns Hopkins University. Capt. Armstrong oversees the hydrographic training program at UNH and organized our successful Category A certification submission to the International Hydrographic Organization in 2018.

**Sam Candio** is a physical scientist with the NOAA Office of Ocean Exploration and Research (OER). He splits his time between conducting field operations aboard the NOAA Ship *Okeanos Explorer* as an expedition coordinator/mapping lead, and conducting shoreside responsibilities at the Center including mission planning, data QC, and data archival. Sam received his Bachelor of Science degree in marine biology from the University of North Carolina, Wilmington, with minors in environmental science and oceanography. Following graduation, he worked as an instructor for UNCW's MarineQuest, leading a suite of marine science experiential learning programs ranging from the generation of biodiesel from algae to the operation of side scan sonars and ROVs. Prior to signing on with OER, Sam spent four years aboard the NOAA Ship *Fairweather*, serving as the chief hydrographic survey technician leading coastal bathymetric surveys ranging from the Alaskan Arctic to the Channel Islands in California.

**Jason Greenlaw** is a software developer for ERT, Inc., working as a contractor for NOAA/National Ocean Service's Coast Survey Development Laboratory in the Marine Modeling and Analysis Programs (MMAP) branch. He works primarily on the development of NOAA's nowCOAST project (<http://nowcoast.noaa.gov>), but also works closely with MMAP modelers to assist in the development of oceanographic forecast systems and the visualization of model output. Jason is a native of Madbury, NH and graduated in May 2006 from the University of New Hampshire with a B.S. in computer science.

**Shannon Hoy** is a physical scientist with the NOAA Office of Ocean Exploration and Research (OER). She assists in both field operations aboard the NOAA Ship *Okeanos Explorer* as a mapping coordinator and with shoreside responsibilities, such as mission planning and data archiving. Shannon has a multidisciplinary background, having

received a Bachelor of Science degree in marine biology from the College of Charleston, and having worked with the Submarine Geohazards Group at the U.S. Geological Survey. She will soon complete her master's degree in ocean mapping at the University of New Hampshire's Center for Coastal and Ocean Mapping (CCOM). Shannon began mapping the seafloor in 2009 and has since participated with numerous expeditions. Prior to her position with OER, the majority of her time at sea was spent as a mapping lead for University of Bristol's (UK) palaeoceanographic group, where she implemented multiple habitat mapping technologies and methodologies to search for deep-sea corals.

**Carl Kammerer** is an oceanographer with the National Ocean Service's Center for Operational Oceanographic Products and Services (CO-OPS), now seconded to the Center. He is a specialist in estuarine and near-shore currents and has been project manager for current surveys throughout the United States and its territories. His present project is a two-year survey of currents in the San Francisco Bay region. He acts as a liaison between CO-OPS and the JHC and provides expertise and assistance in the analysis and collection of tides. He has a B.Sc in oceanography from the University of Washington and an MBA from the University of Maryland University College.

**John G.W. Kelley** is a research meteorologist and coastal modeler with NOAA/National Ocean Service's Marine Modeling and Analysis Programs within the Coast Survey Development Lab. Kelley has a Ph.D. in atmospheric sciences from Ohio State University. He is involved in the development and implementation of NOS's operational numerical ocean forecast models for estuaries, the coastal ocean and the Great Lakes. He is also the PI for a NOAA web-mapping portal to real-time coastal observations and forecasts. John works with Center personnel on developing the capability to incorporate NOAA's real-time gridded digital atmospheric and oceanographic forecast into the next generation of NOS nautical charts.

**Juliet Kinney** graduated with a B.S. in earth systems science from the UMass-Amherst Geosciences Department and received her Ph.D. in marine and atmospheric sciences from Stony Brook University where her dissertation was "The Evolution of the Peconic Estuary 'Oyster Terrain,' Long Island, NY." Her study included high-resolution mapping using a combination of geophysical techniques: multibeam sonar, chirp seismic profiles, and sidescan sonar. She is interested in paleoclimate/paleoceanography and her expertise is as a geological oceanographer in high-resolution sea floor mapping. Before joining the Center, Dr. Kinney was a temporary, full-time faculty member in the Department of Geological Sciences at Bridgewater State University, Bridgewater, MA for one year. Prior to graduate school, she worked at the USGS as an ECO intern for two years in Menlo Park, CA with the Coastal and Marine Geology Program, working primarily with physical oceanographic and sediment transport data.

**Elizabeth "Meme" Lobecker** is a Physical Scientist for the *Okeanos Explorer* program within the NOAA Office of Ocean Exploration and Research (OER). She organizes and leads mapping exploration cruises aboard the NOAA Ship *Okeanos Explorer*. She has spent the last ten years mapping the global ocean floor for an array of purposes, ranging from shallow water hydrography for NOAA charting and habitat management purposes in U.S. waters from Alaska to the Gulf of Maine, cable and pipeline inspection and pre-lay surveys in the Eastern Atlantic Ocean, the North Sea and Mediterranean Sea, and most recently as a Physical Scientist for OER sailing on *Okeanos Explorer* as it explores the U.S. and international waters. So far this has included mapping in Indonesia, Guam, Hawaii, California, the Galapagos Spreading Center, the Mid-Cayman Rise, the Gulf of Mexico, and the U.S. Atlantic continental margin. Lobecker obtained a Master of Marine Affairs degree from the University of Rhode Island in 2008, and a Bachelor of Arts in environmental studies from The George Washington University in 2000. Her interests in her current position include maximizing offshore operational efficiency in order to provide large amounts of high-quality data to the public to enable further exploration, focused research, and wise management of U.S. and global ocean resources.

**Erin Nagel** focused her undergraduate studies at the University of Colorado at Boulder on geographic information systems and atmospheric and oceanic sciences and worked as a physical scientist for the U.S. Army Corps of Engineers and with NOAA's Atlantic Hydrographic Branch for the Office of Coast Survey before joining the Center in 2014. She has supported USACE and FEMA in emergency operations during Super Storm Sandy and Irene with emergency response mapping and pre- and post-storm analysis of bathymetry and lidar. Erin joined the now-COAST effort in 2017, working as a Scientific Programmer focusing on surface current data.

**Glen Rice** started with the Center as a Lieutenant (Junior Grade) in the NOAA Corps stationed with at the Joint Hydrographic Center as Team Lead of the Integrated Ocean and Coastal Mapping Center. He had previously served aboard the NOAA Hydrographic Ships *Rude* and *Fairweather* along the coasts of Virginia and Alaska after receiving an M.Sc. in ocean engineering at the University of New Hampshire. In 2013, Glen left the NOAA Corps and became a civilian contractor to NOAA. In 2014, he became a permanent physical scientist with NOAA. He maintains his position as Team Lead of the IOCM Center at UNH.

**Derek Sowers** works as a physical scientist with the NOAA Office of Ocean Exploration and Research (OER) supporting ocean mapping efforts of the NOAA Ship *Okeanos Explorer*. This work involves overseeing other sonar scientists shore-side at the Center. Derek is also a part-time oceanography Ph.D. student at with interests in seafloor characterization, ocean habitat mapping, and marine conservation. He has a B.S. in environmental science from the University of New Hampshire (1995) and holds an M.S. in marine resource management from Oregon State University (2000) where he completed a NOAA-funded assessment of the “Benefits of Geographic Information Systems for State and Regional Ocean Management.” Derek has thirteen years of previous coastal research and management experience working for NOAA’s National Estuarine Research Reserve network and EPA’s National Estuary Program in both Oregon and New Hampshire and has participated in ocean research expeditions in the Arctic Ocean, Gulf of Maine, and Pacific Northwest continental shelf.

**Michael White** has a B.A. in geological sciences from SUNY Geneseo and an M.S. from the School of Marine and Atmospheric Sciences at Stony Brook University where his graduate work focused on the processing of multibeam sonar and the relationship between backscatter and the physical characteristics of the seafloor for the purposes of habitat mapping. He also has an Advanced Graduate Certificate in Geospatial Science from the Department of Sustainability at Stony Brook University. At the Center, White works with the Ocean Exploration and Research (OER) as a Physical Scientist in the NOAA Ship *Okeanos Explorer* program.

**Katrina Wiley** is part of NOAA’s Office of Coast Survey, Hydrographic Surveys Division, Operations Branch. Prior to Operations Branch, Katrina served as Chief of Survey Section at U.S. Army Corps of Engineers New England District in Concord, MA and also previously worked for NOAA’s Hydrographic Surveys Division Operations Branch in Silver Spring, MD and Atlantic Hydrographic Branch in Norfolk, VA. She has a B.S. in marine biology from the College of Charleston and an M.S. in Earth sciences from University of New Hampshire.

**Sarah Wolfskehl** is a Hydrographic Data Analyst with NOAA’s Sandy IOCM Center. She is located at the Joint Hydrographic Center to utilize the Center’s research to improve and diversify the use of hydrographic data across NOAA in support of Integrated Ocean and Coastal Mapping projects. Previously, she worked as a Physical Scientist for NOAA’s Office of Coast Survey in Seattle, WA. Wolfskehl has a B.A. in biology from The Colorado College.

## Other Affiliated Faculty

**Lee Alexander** is a research associate professor emeritus. He was previously a research scientist with the U.S. Coast Guard, and a Visiting Scientist with the Canadian Hydrographic Service. His area of expertise is applied Research, Development, Test and Evaluation (RDT&E) on electronic charting and e-Navigation-related technologies for safety-of-navigation and marine environmental protection. Lee has published over 150 papers and reports on shipborne and shore-based navigation systems/technologies, and is a co-author of a textbook on Electronic Charting. He received an M.S. degree from the University of New Hampshire, and a Ph.D. from Yale University. He is also a Captain (now retired) in the U.S. Navy Reserve.

**Capt. Andrew Armstrong**—see Capt. Armstrong’s bio under **NOAA Employees**.

**Brad Barr** received a B.S. from the University of Maine, an M.S. from the University of Massachusetts, and a Ph.D. from the University of Alaska. He is currently a senior policy advisor in the NOAA Office of National Marine Sanctuaries, affiliate professor at the School of Marine Sciences and Ocean Engineering at the University of New Hampshire, and a visiting professor at the University Center of the Westfjords in Iceland. He is a member of the IUCN World Commission on Protected Areas, the International Committee on Marine Mammal Protected



Areas/IUCN Marine Mammal Protected Areas Task Force. He has served on the Boards of Directors of the George Wright Society in the U.S., the Science and Management of Protected Areas Association (SAMPAA) in Canada, and, currently, on the Board of Directors of the Coastal Zone Canada Association (CZCA). He also serves on the Editorial Board of the World Maritime University *Journal of Maritime Affairs*. He has published extensively on marine protected areas science and management, whaling and maritime heritage preservation, with a primary research focus on the identification and management of ocean wilderness.

**Jonathan Beaudoin** earned his undergraduate degrees in geomatics engineering and computer science from the University of New Brunswick (UNB) in Fredericton, NB, Canada. He continued his studies at UNB under the supervision of Dr. John Hughes Clarke of the Ocean Mapping Group, and after completing his Ph.D. studies in the field of refraction related echo sounding uncertainty, Dr. Beaudoin took a research position at JHC/CCOM in 2010. While there, he carried on in the field of his Ph.D. research and joined the ongoing seabed imaging and characterization efforts. He also played a leading role in establishing the Multibeam Advisory Committee, an NSF-funded effort to provide technical support to seabed mapping vessels in the U.S. academic fleet. Jonathan returned to Canada in late 2013 where he joined the Fredericton, NB office of QPS.

**Ann E. A. Blomberg** received her M.Sc. and Ph.D. degrees in signal processing from the University of Oslo, Norway, in 2005 and 2012, respectively. From 2005 to 2008, she worked as a processing geo-physicist at CGGVeritas in Norway. In 2012, she was at the Centre for Geobiology (CGB) at the University of Bergen, working with sonar and seismic data acquisition, processing, and interpretation. She is currently a postdoc at the University of Oslo, working on a project entitled, "Advanced sonar methods for detecting and monitoring marine gas seeps."

**David Bradley** received bachelor's and master's degrees in physics from Michigan Technological University in Houghton in 1960 and 1963, respectively, and a doctorate in mechanical engineering from the Catholic University of America in 1970. He served as director of the NATO Underwater Research Center, La Spezia, Italy; superintendent of the Acoustics Division of the Naval Research Laboratory; and mine warfare technical adviser to the Chief of Naval Operations. His seminal contributions to the field of acoustics have been recognized with many awards and leadership positions within the ASA. They include the Meritorious Civilian Service Award in 1982, and the Superior Civilian Service Award in 1993 from the Department of the Navy. He recently retired as a Professor of Acoustics at Penn State University and started as an Affiliate Faculty member with the Center in 2017.

**Margaret Boettcher** received a Ph.D. in geophysics from the MIT/WHOI Joint Program in Oceanography in 2005. She joined JHC/CCOM in 2008 as a post-doctoral scholar after completing a Mendenhall Postdoctoral Fellowship at the U.S. Geological Survey. Although she continues to collaborate with scientists at the Center, Margaret has been a member of the faculty in the Earth Science Department at UNH since 2009. Margaret's research focuses on the physics of earthquakes and faulting and she approaches these topics from the perspectives of seismology, rock mechanics, and numerical modeling. Margaret seeks to better understand slip accommodation on oceanic transform faults. Recently she has been delving deeper into the details of earthquake source processes by looking at very small earthquakes in deep gold mines in South Africa.

**Dale Chayes** has been an active instrument developer, troubleshooter, and operator in the oceanographic community since 1973 and has participated in well over 150 field events. He has worked on many projects, including hull-mounted multibeam, submarine (SCAMP) and deep-towed mapping sonars (SeaMARC I), real-time wireless data systems, database infrastructure for digital libraries (DLESE) and marine geoscience data (MDS), satellite IP connectivity solutions (SeaNet), GPS geodesy, trace gas water samplers, precision positioning systems, and backpack mounted particle samplers. In his spare time, he is a licensed amateur radio operator, Wilderness EMT/NREMT and is in training (with his dog Frodo) for K9 wilderness search and rescue.

**Vicki Ferrini** has a Ph.D. in coastal oceanography (2004) and a master's degree in marine environmental science (1998), both from Stony Brook University. Over the past 20+ years, she has worked in environments from shallow water coastal areas to the deep sea, using ships, boats, submersibles, and towed platforms to map the seafloor at

a variety of resolutions. Vicki is also heavily involved in the fields of geoinformatics and data management. She is a research scientist at Columbia University's Lamont-Doherty Earth Observatory where she spends much of her time working on projects focused on making high-quality marine geoscience research data publicly accessible.

**Denis Hains** is the Founder, President and CEO of H2i (Hains HYDROSPATIAL international inc.); the representative appointed by the United States and Canada Hydrographic Commission (USCHC) on the International Hydrographic Review (IHR) Editorial Board of the International Hydrographic Organization (IHO); Vice President of the Board of Directors of the Interdisciplinary Center for Ocean Mapping Development (CIDCO) in Rimouski, Canada; and is also an active member of the Canadian Hydrographic Association (CHA), and the Association of Professional EXecutives of the Public Service of Canada (APEX). Denis holds a B.Sc. in geodetic science from Laval University in Québec City, Canada. He is a Retired Québec Land Surveyor and had a successful 35+ year career with the Public Service of Canada, where he worked for 20 years for Fisheries and Oceans Canada at the Canadian Hydrographic Service (CHS) in Mont-Joli and Ottawa, including two years with the Canadian Coast Guard. He also spent 15 years with Natural Resources Canada, particularly as the National Executive Director of the Canadian Geodetic Survey (CGS). He retired in 2018 as Director-General of the CHS and Hydrographer General of Canada in Ottawa, Canada.

**John Hall** spent his sabbatical from the Geological Survey of Israel with the Center. Dr. Hall has been a major influence in the IBCM and GEBCO compilations of bathymetric data in the Mediterranean, Red, Black, and Caspian Seas and is working with the Center on numerous data sets including multibeam-sonar data collected in the high Arctic in support of our Law of the Sea work. He is also archiving the 1962 through 1974 data collected from Fletcher's Ice Island (T-3).

**Martin Jakobsson** joined the Center in August of 2000 as a Post-Doctoral Fellow. Martin completed a Ph.D. at the University of Stockholm where he combined modern multibeam sonar data with historical single-beam and other data to produce an exciting new series of charts for the Arctic Ocean. Dr. Jakobsson has been developing robust techniques for combining historical data sets and tracking uncertainty as well as working on developing approaches for distributed database management and Law of the Sea issues. In April 2004, he returned to a prestigious professorship in his native Sweden but remains associated with the Center.

**John G.W. Kelley**—see Dr. Kelley's bio under **NOAA Employees**.

**Scott Loranger** defended his Ph.D. in Oceanography from the University of New Hampshire in November 2018. He is interested in acoustical oceanography and specifically in the use of broadband acoustics to understand physical and biological processes in the water column. His current position is with a project called ACT4Storage: Acoustic and Chemical Technologies for environmental monitoring of geological carbon storage. Geological carbon storage has emerged as a promising method for reducing greenhouse gas emissions and reaching international climate goals. The ACT4Storage project is a collaborative effort aimed at improving the cost-efficiency and effectiveness of environmental monitoring of offshore geological carbon storage sites. Scott's role is in using broadband acoustic systems to detect and quantify potential leaks from storage sites.

**Xavier Lurton** graduated in physics in 1976 (Universite de Bretagne Occidentale, Brest) and received a Ph.D. in applied acoustics in 1979 (Universite du Maine, Le Mans), specializing first in the physics of brass musical instruments. After spending two years of national service as a high-school teacher in the Ivory Coast, he was hired by Thomson-Sintra (the leading French manufacturer in the field of military sonar systems—today Thales Underwater Systems) as an R&D engineer, and specialized in underwater propagation modeling and system performance analysis. In 1989, he joined IFREMER (the French government agency for oceanography) in Brest, where he first participated in various projects in underwater acoustics applied to scientific activities (data transmission, fisheries sonar, ocean tomography, etc.). Over the years, he specialized more specifically in seafloor-mapping sonars, both through his own technical research activity (in both physical modeling and sonar engineering) and through several development projects with sonar manufacturers (Kongsberg, Reson). In this context, he has participated in tens of technological trial cruises on research vessels. He has been teaching underwater acoustics for 20 years in several

French universities, and consequently wrote *An Introduction to Underwater Acoustics* (Springer), heavily based on his own experience as a teacher. Dr. Lurton manages the IFREMER team specialized in underwater acoustics, and has been the Ph.D. advisor of about 15 students. He spent six months as a visiting scholar at UNH in 2012, working on issues related to sonar reflectivity processing, and bathymetry measurement methods.

**David Mosher** is a Professor in the Dept. of Earth Sciences and the Center for Coastal and Ocean Mapping at the University of New Hampshire. He graduated with a Ph.D. in geophysics from the Oceanography Department at Dalhousie University in 1993, following an M.Sc. in Earth Sciences from Memorial University of Newfoundland in 1987 and a B.Sc. at Acadia in 1983. In 1993, he commenced work on Canada's West Coast at the Institute of Ocean Sciences, in Sidney on Vancouver Island, studying marine geology and neotectonics in the inland waters of British Columbia. In 2000, he took a posting at Bedford Institute of Oceanography. His research focus was studying the geology of Canada's deep-water margins, focusing on marine geohazards using geophysical and geotechnical techniques. From 2008 to 2015, he was involved in preparing Canada's submission for an extended continental shelf under the Law of the Sea (UNCLOS) and, in this capacity, he led four expeditions to the high Arctic. In 2011, he became manager of this program and was acting Director from 2014. In 2015, he joined UNH to conduct research in all aspects of ocean mapping, focusing on marine geohazards and marine geoscience applications in Law of the Sea. He has participated in over 45 sea-going expeditions and was chief scientist on 27 of these. In 2018 David took a leave of absence from UNH to represent Canada as a Commissioner on the Limits of the Continental Shelf.

**Christopher Parrish** holds a Ph.D. in civil and environmental engineering with an emphasis in geospatial information engineering from the University of Wisconsin-Madison and an M.S. in civil and coastal engineering with an emphasis in geomatics from the University of Florida. His research focuses on full-waveform lidar, topographic-bathymetric LIDAR, hyperspectral imagery, uncertainty modeling, and UAVs for coastal applications. Dr. Parrish is the Director of the American Society for Photogrammetry and Remote Sensing (ASPRS) Lidar Division and an associate editor of the journal *Marine Geodesy*. Prior to joining Oregon State University, Dr. Parrish served as lead physical scientist in the Remote Sensing Division of NOAA's National Geodetic Survey and as an affiliate professor at the Center.

**Shachak Pe'eri** received his Ph.D. degree in geophysics from the Tel Aviv University, Israel. In 2005, he started his post-doctoral work at the Center with a Tyco post-doctoral fellowship award. His research interests are in optical remote sensing in the littoral zone with a focus on experimental and theoretical studies of LIDAR remote sensing (airborne lidar bathymetry, topographic lidar, and terrestrial laser scanning), hyperspectral remote sensing, and sensor fusion. Shachak is a member of the American Geophysical Union (AGU), the Ocean Engineering (OE) and Geoscience and Remote Sensing (GRS) societies of IEEE, and of The Hydrographic Society of America (THSOA). Dr. Pe'eri moved to a position with NOAA's Marine Chart Division in 2016.

**Kurt Schwehr** received his Ph.D. from Scripps Institution of Oceanography studying marine geology and geophysics. Before joining the Center, he worked at JPL, NASA Ames, the Field Robotics Center at Carnegie Mellon, and the USGS Menlo Park. His research has included components of computer science, geology, and geophysics. He looks to apply robotics, computer graphics, and real-time systems to solve problems in marine and space exploration environments. He has been on the mission control teams for the Mars Pathfinder, Mars Polar Lander, Mars Exploration Rovers and Mars Science Laboratory. He has designed computer vision, 3D visualization, and on-board driving software for NASA's Mars exploration program. Fieldwork has taken him from Yellowstone National Park to Antarctica. At the Center, he worked on a range of projects including the Chart of the Future, visualization techniques for underwater and space applications, and sedimentary geology. He has been particularly active in developing hydrographic applications of AIS data. Kurt is currently Head of Ocean Engineering at Google and an affiliate faculty member of the Center.

**Arthur Trembanis** is the director of the Coastal Sediments, Hydrodynamics and Engineering Laboratory (CSHEL) in the College of Earth, Ocean, and Environment at the University of Delaware. The work of CSHEL involves the development and utilization of advanced oceanographic instrumentation, particularly autonomous underwater



vehicles for seafloor mapping and benthic habitat characterization. He received a bachelor's degree in geology from Duke University in 1998, a Fulbright Fellowship at the University of Sydney in 1999, and a Ph.D. in marine sciences from the Virginia Institute of Marine Sciences in 2004. He is presently a visiting professor at the University of Ferrara.

**Lysandros Tsoulos** is an associate professor of cartography at the National Technical University of Athens. Lysandros is internationally known for his work in digital mapping, geoinformatics, expert systems in cartography, and the theory of error in cartographic databases. At the Center, Lysandros worked with NOAA student Nick Forfinski exploring new approaches to the generalization of dense bathymetric data sets.

**Dave Wells** is world-renowned in hydrographic circles. Dave is an expert in GPS and other aspects of positioning, providing geodetic science support to the Center. Along with his time at UNH, Dave also spends time at the University of New Brunswick and at the University of Southern Mississippi where he is participating in their hydrographic program. Dave also helps UNH in its continuing development of the curriculum in hydrographic training.

**Neil Weston's** research appointment serves as a way to strengthen the academic and research ties between the Center and the Office of Coast Survey, NOAA. His focus will be to collaborate on research activities related to GNSS/GPS positioning, geophysical phenomena affecting land/ocean interfaces, data visualization, digital signal processing, and modeling. Dr. Weston is also interested in advising and mentoring graduate students, giving invited talks and seminars, promoting OCS, NOS and NOAA scientific and technological endeavors, and strengthening high-level collaborations between the academic community and NOAA. Neil received his doctorate from Catholic University of America in 2007 in biomedical engineering and physics, and has master's degrees from Johns Hopkins University in physics (sensor systems) and the University of South Florida in physics (laser optics and quantum electronics). He also holds positions as a Science/Technical Advisor with the U.S. State Department and as a Technical Advisor for the United Nations.

## Visiting Scholars

*Since the end of its first year, the Center has had a program of visiting scholars that allows us to bring some of the top people in various fields to interact with Center staff for periods of between several months and one year.*

**Jorgen Eeg** (October–December 2000) is a senior researcher with the Royal Danish Administration of Navigation and Hydrography and was selected as our first visiting scholar. Jorgen brought a wealth of experience applying sophisticated statistical algorithms to problems of outlier detection and automated cleaning techniques for hydrographic data.

**Donald House** (January–July 2001) spent his sabbatical with our visualization group. He is a professor at Texas A&M University where he is part of the TAMU Visualization Laboratory. He is interested in many aspects of the field of computer graphics, both 3D graphics and 2D image manipulation. Recently his research has been in the area of physically based modeling. He is currently working on the use of transparent texture maps on surfaces.

**Rolf Doerner** (March–September 2002) worked on techniques for creating self-organizing data sets using methods from behavioral animation. The method, called "Analytic Stimulus Response Animation," has objects operating according to simple behavioral rules that cause similar data objects to seek one another and dissimilar objects to avoid one another.

**Ron Boyd** (July–December 2003) spent his sabbatical at the Center. At the time, Ron was a professor of marine geology at the University of Newcastle in Australia and an internationally recognized expert on coastal geology and processes. He is now an employee of Conoco-Phillips Petroleum in Houston. Ron's efforts at the Center focused on helping us interpret the complex, high-resolution repeat survey data collected off Martha's Vineyard as part of the ONR Mine Burial Experiment.

**John Hall** (August 2003–October 2004). See Dr. Hall's biography under **Affiliate Faculty**.

**LCDR Anthony Withers** (July–December 2005) was the Commanding Officer of the HMAS Ships *Leeuwin* and *Melville* after being officer in charge of the RAN Hydrographic School in Sydney, Australia. He also has a Masters of Science and Technology in GIS Technology and a Bachelor of Science from the University of New South Wales. LCDR Withers joined us at sea for the Law of the Sea Survey in the Gulf of Alaska and upon returning to the Center focused his efforts on developing uncertainty models for phase-comparison sonars.

**Walter Smith** (November 2005–July 2006) received his Ph.D. in Geophysics from Columbia University's Lamont-Doherty Earth Observatory in 1990. While at Lamont, he began development of the GMT data analysis and graphics software. From 1990-1992 he held a post-doctoral scholarship at the University of California, San Diego's Scripps Institution of Oceanography in the Institute for Geophysics and Planetary Physics. He joined NOAA in 1992 and has also been a lecturer at the Johns Hopkins University, teaching Data Analysis and Inverse Theory. Walter's research interests include the use of satellites to map the Earth's gravity field, and the use of gravity data to determine the structure of the sea floor and changes in the Earth's oceans and climate.

**Lysandros Tsoulos** (January-August 2007). See Dr. Tsoulos's biography under **Affiliate Faculty**.

**Jean-Marie Augustin** (2010) is a senior engineer at the Acoustics and Seismics Department of IFREMER focusing on data processing and software development for oceanographic applications and specializing in sonar image and bathymetry processing. His main interests include software development for signal, data and image processing applied to seafloor-mapping sonars, featuring bathymetry computation algorithms and backscatter reflectivity analysis. He is the architect, designer and main developer of the software suite, *SonarScope*.

**Xabier Guinda** (2010) is a postdoctoral research fellow at the Environmental Hydraulics Institute of the University of Cantabria in Spain. He received a Ph.D. from the University of Cantabria. His main research topics are related to marine benthic ecology (especially macroalgae), water quality monitoring and environmental assessment of anthropogenically disturbed sites as well as the use of remote sensing hydroacoustic and visual techniques for mapping of the seafloor and associated communities. His tenure at the Center was sponsored by the Spanish government.

**Sanghyun Suh** (2010) is a Senior Research Scientist at the Maritime and Ocean Engineering Research Institute (MOERI) at the Korea Ocean Research and Development Institute (KORDI) in Daejeon, Republic of Korea (South Korea). Dr. Suh received his Ph.D. from the University of Michigan in GIS and Remote Sensing. He worked with Dr. Lee Alexander on e-Navigation research and development (R&D) related to real-time and forecasted tidal information that can be broadcast via AIS binary application-specific messages to ship-borne and shore-based users for situational awareness and decision-support.

**Xavier Lurton** (August 2010–March 2012). See Dr. Lurton's biography under **Affiliate Faculty**.

**Seojeong Lee** (April 2012–April 2013) received her Ph.D. in computer science with an emphasis on software engineering from Sookmyung Women's University in South Korea. She completed an expert course on software quality at Carnegie Mellon University. With this software engineering background, she has worked at the Korea Maritime University as an Associate Professor since 2005 where her research has been focused on software engineering and software quality issues in the maritime area. As a Korean delegate of the IMO NAV sub-committee and IALA e-NAV committee, she contributes to the development of e-navigation. Her current research topic is software quality assessment of e-navigation, and development of e-navigation portrayal guidelines. She is also interested in AIS ASM and improvement of NAVTEX message.

**Gideon Tibor** (April 2012–November 2012) was a visiting scholar from the Israel Oceanographic and Limnological Research Institute and the Leon H. Charney School of Marine Sciences in the University of Haifa. Gideon received his Ph.D. in geophysics and planetary sciences from Tel-Aviv University. His main research interest is the development and application of high-resolution marine geophysics and remote sensing using innovative methods in the study of phenomena that influence the marine environment and natural resources. By means of international and local competitive research grants, he uses a multi-disciplinary approach for studying the Holocene evolution of the Levant margin, the Sea of Galilee, and the northern Gulf of Eilat/Aqaba.

**Anne E.A. Blomberg** (December 2014–February 2015). See Dr. Blomberg's biography under **Affiliate Faculty**.

**Tor Inge Lønmo** (June 2016–December 2016) received a master's degree in mathematics and physics at the Norwegian University of Science and Technology in 2012. His thesis was done in cooperation with the Norwegian Defence Research Establishment (FFI). Shortly after, he started working for Kongsberg Maritime in Horten. He is currently working on improving the beam forming for the EM2040 multibeam echo sounder through a Ph.D. at the University of Oslo.

**Christian Stranne** (January 2017–December 2017) received his Ph.D. in 2013 in physical oceanography from the University of Gothenburg, where he studied large-scale Arctic sea ice dynamics and coupled ocean-sea ice-atmosphere interactions. He has held a two-year postdoc position at Stockholm University, focusing on methane hydrate dynamics and numerical modelling of multiphase flow in hydrate-bearing marine sediments. Dr. Stranne is funded by the Swedish Research Council for a three-year research project of which two years are based at the Center. The project involves the modelling of methane gas migration within marine sediments, and studies of the interaction between gas bubbles and sea water in the ocean column with an over-arching aim to set up a coupled model for methane transport within the sediment-ocean column system. He is also involved in a project evaluating water column multibeam and single-beam sonar data for its potential of revealing detailed oceanographic structure.

**Kelly Hogan** (January–March 2018) is a marine geophysicist with the British Antarctic Survey in Cambridge England who specializes in reconstructing past Arctic and Antarctic ice sheets. Specifically, Dr. Hogan uses glacial geomorphology and sedimentary processes at the seafloor (imaged and sampled from ships) to determine past patterns of ice flow and how quickly the ice retreated since the last glacial some 20,000 years ago. She links these results to past, natural changes in climate helping to improve our understanding of the response of the Cryosphere to future climatic change. At the Center, Dr. Hogan worked with Larry Mayer and graduate student Erin Heffron on the interpretation of multibeam, sub-bottom and water column data from the Arctic Ocean.



## Facilities, IT and Equipment

### Office and Teaching Space

The Joint Hydrographic Center has the good fortune to have equipment and facilities that are unsurpassed in the academic hydrographic community. Upon the initial establishment of the Center at UNH, the University constructed an 8,000-square-foot building dedicated to JHC/CCOM and attached to the unique Ocean Engineering high-bay and tank facilities already at UNH. Since that time, a 10,000-square-foot addition has been constructed (through NOAA funding), resulting in 18,000 sq. ft. of space dedicated to Center research, instruction, education, and outreach activities. In 2016, construction began on 12,000-square-foot expansion to the building that was completed in September 2017. This new construction includes six large labs and office space for the new undergraduate ocean engineering program, nine new offices (1,600 sq. ft.) dedicated for the Center personnel, and a new shared 84-seat amphitheater-style class/seminar room with the latest in projection facilities (Figures I-1).



Figure I-2. An early morning drone shot of Chase Ocean Engineering Lab.

The Center now has 20,000 sq. ft. of dedicated space (Figure I-2), of which approximately 4,000 sq. ft. are devoted to teaching purposes and 16,000 sq. ft. to research and outreach, including office space. This does not include the new lab or seminar space (Figure 3) which are shared with the Center for Ocean Engineering and the B.S. program in Ocean Engineering. Our dedicated teaching classroom can

seat 45 students and has a high-resolution LCD projector capable of widescreen display. There are now 43 faculty or staff offices. With the influx of NOAA OER, IOCM and NOAA contractors, the Center is now providing office space under a separate contract with NOAA for 14 NOAA personnel. In 2016, graduate student space was upgraded to accommodate 31 student cubicles plus an additional seven seats for the GEBCO students including space for up to three NOAA students. Two additional NOAA cubicles are available for NOAA Marine Operations Center employees at the pier support facility in New Castle (see Pier Facilities below).

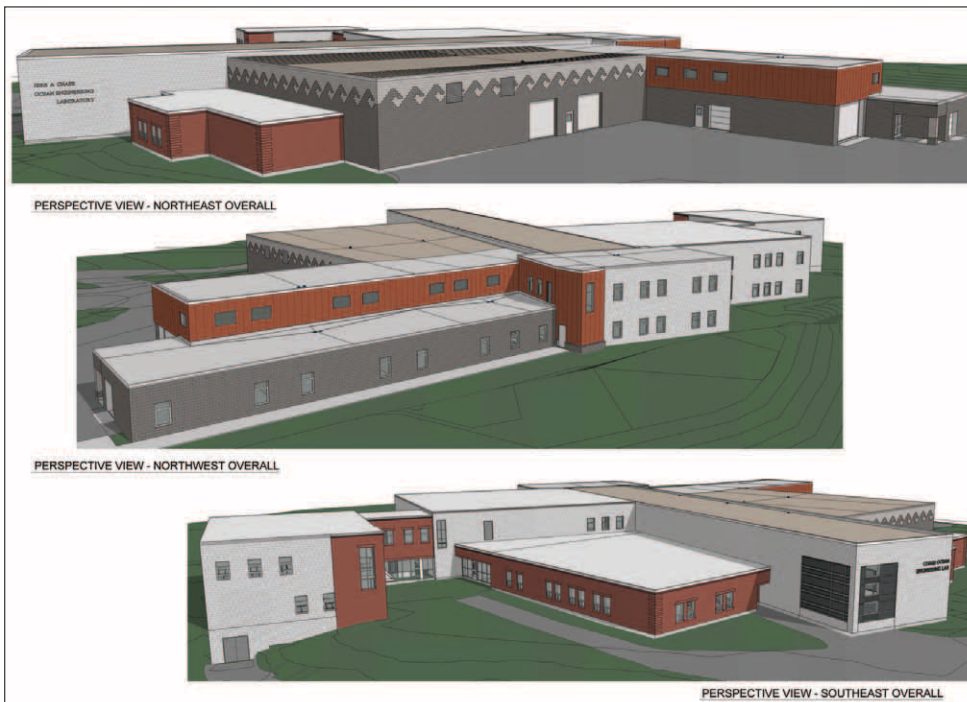

Figure I-1. Perspective views of Chase Ocean Engineering Lab and the NOAA/UNH Joint Hydrographic Center including new lab and office construction (left side of upper frames) and large classroom/seminar room (right side of lower frame).



Figure I-3. New 84-seat seminar/classroom built as part of the 2017 expansion of the Chase Ocean Engineering Lab.

## Laboratory Facilities

Laboratory facilities within the Center include a map room with light tables and map-storage units, and a number of specialized labs for training, equipment testing and development, visualization, and “telepresence interactions.” The Center has a full suite of printers, including a large format, multifunction plotter. Users have the ability to print documents as large as 44” on the short side, as well as scan documents and charts up to 36”. The Center has phased out single-function laser printers in favor of fewer—and more efficient—multi-function printers that are capable of printing, scanning, copying, and faxing documents. The last of the single function printers was retired in late 2017. A vendor contracted by UNH now provides all maintenance and supplies for these multifunction printers, reducing overall labor and supply costs.

The JHC/CCOM Presentation Room houses the Telepresence Console (Figure I-3) as well as the Geowall high-resolution multi-display system. The Geowall, upgraded in early 2018 to feature four, 55” 4k displays, is a multipurpose system utilized for the display of additional video streams from Telepresence-equipped UNOLS vessels, as well as educational and outreach purposes. The hardware for the Telepresence Console consists of

three high-end Dell Precision workstations used for data processing, one Dell multi-display workstation for streaming and decoding real-time video, three 42” LG HDTV displays through which the streams are presented, and a voice over IP (VoIP) communication device used to maintain audio contact with all endpoints (Figure I-4). The multi-display Dell workstation provides MPEG-4 content streaming over Internet2 from multiple sources concurrently. All systems in the Presentation Room are connected to an Eaton Powerware UPS to protect against power surges and outages. Over the last several field seasons, the Center



Figure I-4. The Telepresence Console in action.



has joined forces with the NOAA Ship *Okeanos Explorer* and The Ocean Exploration Trust's exploration vessel *Nautilus* on their respective research cruises. Both vessels have had successful field seasons each year since 2010 utilizing the Telepresence technology to process data and collaborate with scientists and educators ashore. The Center's IT Group expects to utilize both the Telepresence Console and the Geowall to support all current and future telepresence initiatives, as well as provide support for a number of outreach initiatives.



Figure I-5. The Center's Computer Teaching Lab.

The Center's Computer Classroom consists of 15 Dell workstations (Figure I-5). A ceiling-mounted NEC high resolution projector is used to provide classroom instruction. All training that requires the use of a computer system is conducted in this room. Students also frequently use the classroom for individual study and collaborative projects. In addition to these purposes, a high-resolution camera allows for web conferencing and remote teaching. The lab received a refresh in the summer of 2019, with all new workstations to support the wide variety of training software and curriculum requirements.

The JHC/CCOM Video Classroom also provides for web conferencing, remote teaching, and the hosting of webinars and other talks. Combined with the newly constructed, 84-seat Ocean Engineering classroom, the IT Group collaborates with the Ocean Engineering/CCOM organizers to host a weekly live seminar. Building on the success of the 2011 through 2019 seminar series, the IT Group plans to continue to make improvements to both the quality and accessibility of these seminars through better video and audio hardware, as well as distribution of the finished

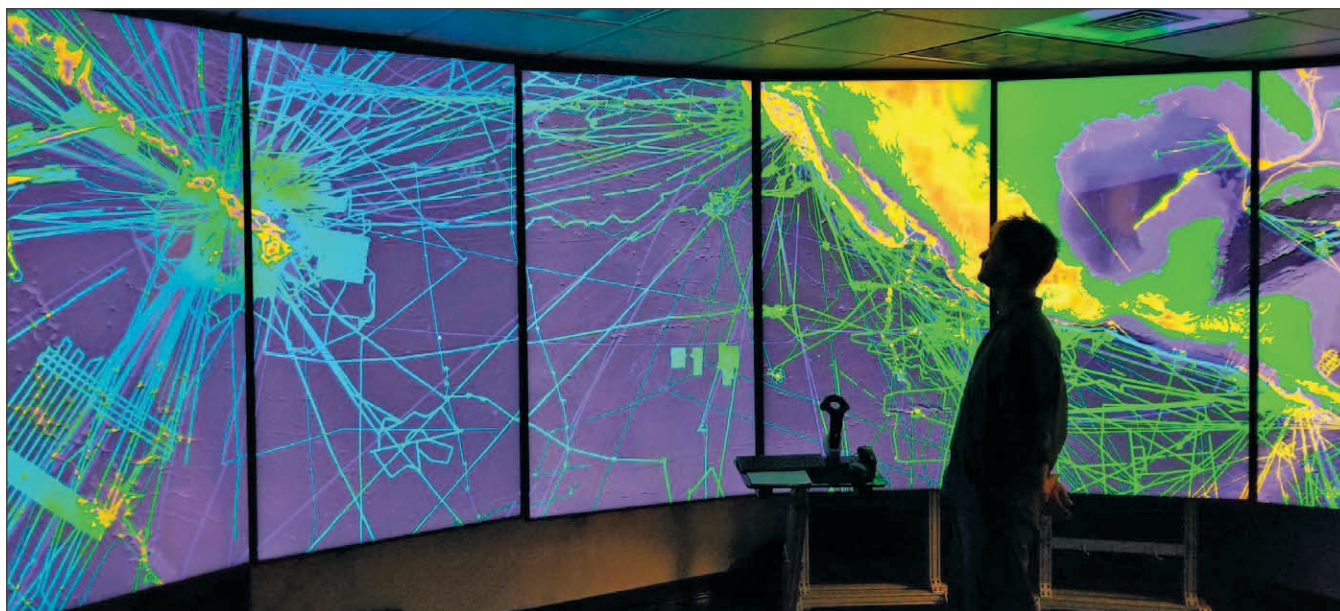

Figure I-6. The VisLab's semi-immersive, large-format tiled display.





Figure I-7. Engineering test tank being used to test the IMU and multibeam on the BEN (Bathymetric Explorer and Navigator) ASV.

We have also built a Lidar Simulator Lab, providing a secure and safe environment in which to perform experiments with our lidar simulator. The Center also maintains a full suite of survey, testing, electronic, and positioning equipment.

The Center is co-located with the Chase Ocean Engineering Lab. The Lab contains a high-bay facility that includes extensive storage and workspace in a warehouse-like environment. The high bay consists of two interior work bays and one exterior work bay with power, lights, and data feeds available throughout. A 5000-lb. capacity forklift is available.

product through the JHC/CCOM website, Vimeo, and YouTube. A key component of these improvements is the use of UNH's Zoom web conferencing software, which provides a reliable, flexible platform for web collaboration and communication of all kinds.

The Center's Visualization Lab includes VIVE Pro Eye and ASL eye-tracking systems and a SteamVR Base Station 2.0 room-wide tracking system for collecting data in human factors studies, an immersive large-format tiled display, custom 3D multi-touch monitors, a Microsoft HoloLens augmented reality headset, and a virtual reality system with custom force-feedback ship's wheel and throttle. The immersive tiled display consists of six vertically mounted 82-inch 4K monitors, in a curved arc (Figure I-6), allowing it to completely fill the field-of-view of users. Its 50-megapixel resolution permits viewing of extremely large datasets without loss of detail, and is used for collaborative analysis, ship simulations, ROV telepresence, and presentations to large groups. Custom-built multi-touch stereoscopic 3D displays are used for interactive exploratory analysis of ocean flow models and other complex datasets. A Valve Index virtual reality system with a high resolution (2880x1600) stereoscopic 3D head-mounted display, two hand-held six degree-of-freedom controllers, and a laser-based system for precisely tracking these components anywhere within the lab, allows users to naturally walk around virtual environments, e.g., a ship's bridge, and is currently being used for our "Chart of the Future" research.

Two very special research tanks are also available in the high bay. The wave/tow tank is approximately 120 ft. long, 12 ft. wide and 8 ft. deep. It provides a 90-foot length in which test bodies can be towed, subjected to wave action, or both. Wave creation is possible using a hydraulic flapper-style wave-maker that can produce two-to-five second waves of maximum amplitude approximately 1.5 feet. Wave absorption is provided by a saw-tooth style geo-textile construction that has an average 92% efficiency in the specified frequency range. The wave-maker software allows tank users to develop regular or random seas using a variety of spectra. A user interface, written in LabView, resides on the main control station PC and a wireless LAN network allows for communication between instrumentation and data acquisition systems. Data acquisition has been vastly improved with 32 channels of analog input, four channels of strain measurement, and Ethernet and serial connectivity all routed through shielded cabling to the main control computer. Power is available on the carriage in 120 or 240 V. In 2019, the wave-tank saw 24 days of use by the Center.

The engineering tank is a freshwater test tank 60 ft. long by 40 ft. wide with a nominal depth of 20 ft. (Figure I-7). The 380,000 gallons that fill the tank are filtered through a 10-micron sand filter twice per day providing an exceptionally clean body of water in which to work. This is a multi-use facility hosting the UNH SCUBA course, many of the OE classes in acoustics and buoy dynamics, as well as providing a

controlled environment for research projects ranging from AUVs to zebra mussels. Mounted at the corner of the Engineering Tank is a 20-foot span, wall-cantilevered jib crane. This crane can lift up to two tons with a traveling electric motor controlled from a hand unit at the base of the crane. In 2003, with funding from NSF and NOAA, an acoustic calibration facility was added to the engineering tank. The acoustic test-tank facility is equipped to do standard measurements for hydrophones, projectors, and sonar systems. Common measurements include transducer impedance, free-field voltage sensitivity (receive sensitivity), transmit voltage response (transmit sensitivity), source-level measurements and beam patterns. The standard mounting platform is capable of a computer-controlled full 360-degree sweep with 0.1-degree resolution. We believe that this tank is the largest acoustic calibration facility in the Northeast and is well suited for measurements of high-frequency, large-aperture sonars when far-field measurements are desired. In 2019, the engineering tank saw 90 days of use by the Center.

Several other specialized facilities are available in the Chase Ocean Engineering Lab to meet the needs of our researchers and students. A 720 sq. ft. machine shop equipped with a milling machine, a tool-room lathe, a heavy-duty drill press, large vertical and horizontal band saws, sheet metal shear and standard and arc welding capability are available for students and researchers. A 12 ft. x 12 ft. overhead door facilitates entry/exit of large fabricated items; a master machinist/engineer is on staff to support fabrication activities. Since 2015 dedicated space has been made available to support our autonomous vehicle activities. Since 2018, the Center has also leased 1600 sq. ft. of secure warehouse space at an offsite facility near the campus (GOSS Building) to support the new iXblue DriX Autonomous Surface Vehicle made available to the Center in collaboration with NOAA and iXblue to explore the viability of this new system for hydrographic surveys. To support these activities we have built a 30' x 60' cage with biometric and network monitored security, electrical power, workstation space, workbenches, tools, and tool storage. The facility also boasts overhead laterally translating cranes with lift capacity of 5 and 10 ton per bridge allowing the maneuvering of the DriX ASV with its launch and recovery system into and out of this facility onto and off the dedicated 26' flatbed. Additionally, the cranes are able to move the 40' custom-built container into this facility for protection from weather.

## Pier Facilities

In support of the Center and other UNH and NOAA vessels, the University constructed a new pier facility in New Castle, NH in 2008. The pier is a 328-foot-long and 25-foot-wide concrete structure with approximately 15 ft. of water alongside. The pier can accommodate UNH vessels and, in 2013, became the homeport for the NOAA Ship *Ferdinand R. Hassler*, a 124-foot LOA, 60-foot breadth, Small Waterplane Area Twin Hull (SWATH) Coastal Mapping Vessel (CMV)—the first of its kind to be constructed for NOAA. Services provided on the new pier include 480V-400A and 208V- 50A power with TV and telecommunications panel, potable water and sewerage connections. In addition to the pier, the University constructed a pier support facility with approximately 4,500 sq. ft. of air-conditioned interior space, including offices, a dive locker, a workshop, and storage. Two additional buildings (1,100 sq. ft. and 1,300 sq. ft.) are available for storage of the variety of equipment and supplies typically associated with marine operations.

## Information Technology

The IT Group currently consists of four full-time staff members and two part-time helpdesk staff. Will Fessenden fills the role of Systems Manager and deals primarily with the day-to-day administration of the Center network and server infrastructure. Appointed in March of 2018 and having previously served as Systems Administrator for over 10 years, he is also responsible for leading the development of the Information Technology strategy for the Center. Paul Johnson, the Center's Data Manager, is responsible for organizing and cataloging the Center's electronic data stores. Paul is currently exploring different methods and products for managing data, and verifying that all metadata meets industry and international standards. Daniel Tauriello serves as an IT support technician, specializing in marine systems and the day-to-day operations of the Center's survey vessels. Systems Administrator Michael Sleep joined the IT staff in December of 2018, and serves as the IT Group's primary Linux administrator. IT facilities within Chase Ocean Engineering Lab consist of a primary data center, two network closets, a laboratory, the Presentation Room, a computer teaching classroom, and several staff offices. The primary data center in the south wing of the building houses the majority of the backend IT infrastructure at the Center. This

space, combined with the two other network closets, gives the Center the capacity to house 22 full-height server racks. The primary data center is equipped with redundant air conditioning, temperature and humidity monitoring, security cameras, and FE-227 fire suppression systems. Additionally, the IT Group employs a natural gas generator to provide power and HVAC to the primary data center in the event of a major outage. The IT lab provides ample workspace for the IT Group to carry out its everyday tasks and securely store sensitive computer equipment. The IT staff offices are located adjacent to the IT lab.

All Center servers, storage systems, and network equipment are consolidated into nine full height cabinets with one or more Uninterruptible Power Supplies (UPS) per cabinet. At present, there are a total of 20 physical servers, 34 virtual servers, two NetApp storage systems fronting 16 disk arrays, and two compute clusters consisting of 15 total nodes. A Palo Alto Networks PA-3020 next-generation firewall provides boundary protection for our 10-gigabit and gigabit Local Area Network (LAN).

At the heart of the Center's network lies its robust networking equipment. A Dell/Force10 C300 switch serves as the core routing and switching device on the network. It is currently configured with 192 gigabit Ethernet ports, all of which support Power over Ethernet (PoE), as well as 32 10-gigabit Ethernet ports.



Figure I-8. Center SAN and NAS infrastructure in the primary server room.

The 10-gigabit ports provide higher-throughput access to network storage and the Center's compute cluster. A Brocade ICX 6610 switch stack provides 192 gigabit Ethernet ports for workstation connectivity and 32 10-gigabit Ethernet ports, used for access to the network backbone as well as for certain workstations needing high-speed access to storage resources. These core switching and routing systems are supplemented with three Dell PowerConnect enterprise-class switches, a Ubiquiti Unifi wireless network platform with eight access points, and a QLogic SANBox 5800 Fibre Channel switch. PowerConnect switches handle edge applications and out-of-band management for servers and network equipment. A SANBox 5800 provides Fibre Channel connectivity to the NetApp Storage Area Network for backups and high-speed server access to other storage resources. C300 PoE ports power the wireless access points as well as the various Axis network cameras used to monitor physical security in the Chase Lab data centers. Ubiquiti wireless access points provide wireless network connectivity for both employees and guests. Access to the internal wireless network is secured through the use of the 802.1x protocol utilizing the Extensible Authentication Protocol (EAP) to identify wireless devices authorized to use the internal wireless network.

Increasing efficiency and utilization of server hardware at the Center remains a top priority. The Center has set out to virtualize as many servers as possible, and to use a "virtualize-first" method of implementing new servers and services. To this end, the IT staff utilizes a three-host VMware ESX cluster managed as a single resource with VMware vSphere. The cluster utilizes VMware High Availability and vMotion to provide a flexible platform for hosting virtual machines. All virtual machines in the cluster are stored in the Center's high-speed SAN storage system, which utilizes snapshots for data protection and deduplication for storage efficiency. An additional VMware ESXi host serves as a test platform. Together, these systems serve between 30 to 50 virtual servers at any time, which include the Center's email server, email security appliance, CommVault Simpana backup management server, Visualization Lab web server, the Center's Certification Authority server, several Linux/Apache web servers, an NTRIP server for RTK data streams, a Windows Server 2016 domain controller, an FTP server, two Oracle database servers, and an ESRI ArcGIS development server. In early 2019, the primary VMware ESX cluster was replaced with a newly-purchased



three-node cluster, which allows for hosting of nearly twice as many virtual machines, and adds improved vMotion support, as well as faster throughput to core network infrastructure.

In 2017, the IT Group purchased, implemented, and migrated to the Center’s next-generation NetApp storage systems, effectively replacing the previous NetApp FAS3240 storage appliances. The current cluster consists of two FAS8020 nodes and two FAS2650 nodes, with a total usable capacity of roughly 600TB (Figure I-8). The FAS8020s were purchased so that a significant portion of disks from the old storage system could be reused with the new cluster. This drastically reduced the purchase cost of the new storage system, while nearly doubling the Center’s usable network storage capacity. In late 2019, two additional 192TB disk shelves were added to increase the total usable capacity of the cluster to roughly 850TB. Like the previous generation of NetApp storage systems, the FAS8020s and FAS2650s operate in a high-availability cluster, offer block-level de-duplication and compression to augment efficiency of disk usage, and support a number of data transfer protocols, including iSCSI, Fibre Channel, NFS, CIFS, and NDMP. In addition to the robust management tools available in NetApp’s OnCommand web console, the IT Group utilizes Microsoft’s Distributed File System (DFS) to organize all SAN and NAS data shares logically by type. A custom metadata cataloging web application was developed to make discovering and searching for data easier for both IT Staff and the Center as a whole.

Constantly increasing storage needs create an ever-increasing demand on the Center’s backup system. To meet these demands, the IT Group utilizes a CommVault Simpana backup solution which consists of two physical backup servers, three media libraries, and the Simpana software management platform. This environment provides comprehensive protection for workstation, server, and storage systems. Simpana utilizes de-duplicated disk-to-disk backup in addition to magnetic tape backup, providing two layers of data security and allowing for more rapid backup and restore capabilities. For magnetic tape backup, the IT Group utilizes a pair of Dell PowerVault TL4000 LTO7 tape libraries, capable of backing up 250TB of data without changing tapes. Full tapes from both libraries are vaulted in an off-site storage facility run by Iron Mountain. Additional upgrades were made to the system in 2019, including a platform update to Simpana 11 which allows the IT Group to serve the latest Windows and Unix/Linux operating systems,

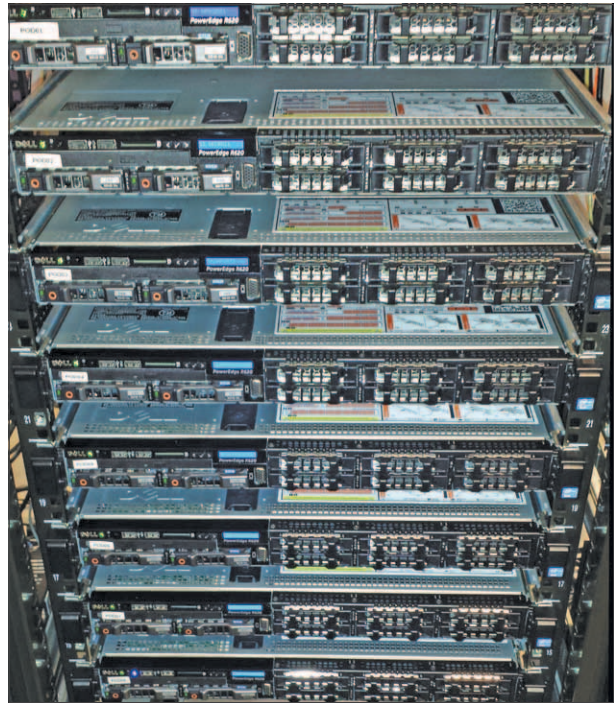

Figure I-9. Dell computer cluster in its rack.

and a new CommVault media agent server, which serves to replace aging server hardware.

As previously mentioned, the Center’s network is protected by a Palo Alto Networks PA-3020 next-generation firewall. The firewall provides for high-performance packet filtering, intrusion prevention, malware detection, and malicious URL filtering. A Cisco ASA 5520 firewall serves as a remote access gateway, providing a SSL VPN portal, which permits access to JHC/CCOM network services remotely.

The IT staff maintains an eight-node Dell compute cluster, running Windows HPC Server 2012 (Figure I-9). The cluster utilizes eight enterprise-class servers with 20 CPU cores and 64 GB of RAM per system, totaling 160 CPU cores and 512 GB of RAM. The cluster is used for resource-intensive data processing, which frees up scientists’ workstations while data is processed, allowing them to make more efficient use of their time and resources. The cluster runs MATLAB DCS, and is used as the test-bed for developing next-generation, parallel-processing software with Industrial Consortium partners. A legacy Dell cluster hardware, installed in 2008 and consisting of seven nodes, sees continued use as a test environment for a variety of parallel processing applications.

The Center has continued to upgrade end users’ primary workstations, as both computing power

requirements, and the number of employees and students have increased. There are currently 280 high-end Windows and Linux desktops/laptops, as well as 26 Apple computers that serve as faculty, staff, and student workstations. All Windows workstations at the Center are running Windows 10 Professional or Windows 7 Pro. With Microsoft ending support for Windows 7 in early 2020, the IT staff has completed the update process for all critical workstations to Windows 10, with a few Windows 7 computers remaining in operation for off-network, legacy applications. On the Apple side, macOS versions 10.13 and 10.14 are in-use throughout the Center. Linux servers are a mix of CentOS 6/7, and the Center's Linux desktop environment primarily uses Ubuntu 16.04/18.04 LTS.

Information security is of paramount importance for the IT Group. For the last several years, Center staff have been working with NOS and OCS IT personnel to develop and maintain a comprehensive security program for both NOAA and the Center systems. The security program is centered on identifying systems and data that must be secured, implementing strong security baselines and controls, and proactively monitoring and responding to security incidents. Recent measures taken to enhance security include the installation of a virtual appliance-based email security gateway, designed to reduce the amount of malicious and spam email reaching end users. The aforementioned Palo Alto firewall was installed in 2015 to replace the Center's legacy firewall/IPS hardware. The Center also utilizes Windows Defender and Eset antivirus protection on Windows and macOS systems at the Center, with Clam AV being utilized on Linux workstations and servers. Microsoft Windows Server Update Services (WSUS), upgraded to version 10 in 2019, is used to provide a central location for Center workstations and servers to download Microsoft updates. WSUS allows the IT staff to track the status of updates on a per-system basis, greatly improving the consistent deployment of updates to all systems.

In an effort to tie many of these security measures together, the IT Group utilizes Nagios for general network and service monitoring. Nagios not only provides for enhanced availability of services for internal systems, but has been a boon for external systems that are critical pieces of several research projects, including AIS ship tracking for the U.S. Coast Guard. External monitoring of the Center's network uptime is also accomplished using a service called Uptime Robot, which serves as an offsite-redundant check on systems hosted on Center and UNH networks.

In addition to Nagios and Uptime Robot, a security event management system, utilizing Open Source Security (OSSEC) and Splunk, is utilized for security event monitoring and reporting. OSSEC performs threat identification, and log analysis. Splunk is used for data mining and event correlation across systems and platforms.

With respect to physical security, Center utilizes an electronic door access system, which provides 24/7 monitoring and alerting of external doors and sensitive IT areas within the facility. This system was updated in 2019 to include additional security features, and to monitor additional entry and exit points. The primary data center utilizes two-factor authentication to control physical access. Security cameras monitor the data center as well as the network closet in the building. Redundant environment monitoring systems, managed internally at the Center and centrally through UNH Campus Energy, keep tabs on the temperature and humidity sensors in the data center and network closet.

The IT Group utilizes Request Tracker, a helpdesk ticket tracking software published by Best Practical. Staff, students, and faculty have submitted over 20,000 Request Tracker tickets since its inception in mid-2009. Through mid-2019, the IT Staff was able to resolve over 90% of tickets within three days. The software is also used for issue tracking by the administrative staff, lab and facilities support team, web development team, and scientists supporting the NSF Multibeam Advisory Committee (MAC) project.

The Center continues to operate within a functional Windows 2008 R2 Active Directory domain environment. This allows the IT Group to take advantage many modern security and management features available in Windows 7 and later operating systems. The Active Directory environment also provide DHCP, DNS, and DFS services. Configurations can be deployed via Active Directory objects to many computers at once through Group Policies, thus reducing the IT administrative costs in supporting workstations and servers. This also allows each member of the Center to have a single user account, regardless of computer platform and/or operating system, reducing the overall administrative cost in managing users. In addition, the IT Group maintains all NOAA computers in accordance with OCS standards. This provides the NOAA-based employees located at the Center with enhanced security and data protection. With support for Windows Server 2008 R2 and Windows 7 ending in early 2020, the IT Group has migrated all AD, DNS

and DHCP, and DFS services in its environment to Windows Server 2016, and is expected to migrate the domain to a functional 2016 domain level in early 2020, following the completion of upgrading all Windows desktop operating systems in the environment to Windows 10.

The Center utilizes Bitbucket to facilitate software collaboration between its own members as well as industrial partners and other academic colleagues. Bitbucket is a source control management solution that hosts Mercurial and Git software repositories. Atlassian, the company behind Bitbucket, states that Bitbucket is SAS70 Type II compliant and is also compliant with the Safe Harbor Privacy Policy put forth by the U.S. Department of Commerce. Given Bitbucket's flexibility and ease-of-use, the IT Group has migrated its local SVN/Mercurial repositories hosted locally to the Bitbucket platform in 2018. This move reduces the administrative overhead while giving users more options for collaboration.

The JHC/CCOM website, <http://ccom.unh.edu>, utilizes the Drupal content management system. Drupal allows for content providers within the Center to make changes and updates with limited assistance from web developers. Drupal also allows for the creation of a more robust platform for multimedia and other rich content, enhancing the user experience of visitors to the site.

Work also continues on several other web-based platforms, providing services for users within the Center, as well as for the general public. The Center continues to utilize an Intranet services platform using Drupal content management software. The Intranet provides a centralized framework for a variety of information management tools, including the Center's wiki, purchase tracking, library, data cata-



Figure I-10. The Pier Support Building at the UNH Coastal Marine Lab in New Castle, New Hampshire. Photo courtesy of Matt Pickett, Oceans Unmanned.

log, and progress reporting systems. The progress reporting system is now in its eighth reporting period and is an instrumental tool in the compilation of this JHC annual report. Launched in 2019, the Center's ePOM platform now provides current and future students with educational resources for learning the Python programming language, which is an important component of the Center's academic program. Additionally, development and deployment of the Center's upgraded ArcGIS data services was recently completed, with a new GIS web server launched in November of 2018. This platform now serves data more efficiently than the two legacy servers it replaced. As all of these web resources evolve, more web services may be brought online to assist in the search for Center-hosted data and access to this data through Intranet-based mapping services.

The Center maintains key IT infrastructure at UNH's Coastal Marine Lab facility in New Castle, NH. At the site's Pier Support Building, the Center's core network is extended through the use of a Cisco ASA VPN device. This allows a permanent, secure connection between the New Castle site and the Chase Ocean Engineering Lab over a UNH-leased public gigabit network. The VPN connection allows the IT Group to easily manage Center systems at the facility using remote management and, conversely, systems at the facility have access to resources at Chase Lab. The Center's research vessels' networks and computer systems are also maintained by the IT Group, with Daniel Tauriello providing primary IT and vessel support at the pier. All launches have access to internet connectivity through a wireless network provisioned by the Coastal Marine Lab, and also through 4G LTE cellular data when away from the pier.

In September of 2013, UNH received a grant from the National Science Foundation intended to improve campus network infrastructure. The express intent of the grant was to improve bandwidth and access to Internet2 resources for scientific research. The Center was identified in the grant as a potential beneficiary of this improved access, and the project achieved operational state in late 2015, providing a 20-gigabit connection to UNH's Science DMZ, and from there a 10-gigabit connection to Internet2. In 2018, UNH's Internet2 service, shared with the University of Maine, was upgraded to support 100 Gbps throughput. This infrastructure has allowed for improved performance of the UNOLS telepresence video streams, as well as for the fast and secure transmission of data to NOAA NCEI. The IT Group is currently looking into leveraging this bandwidth for other collaborative projects on and off campus.



## Research Vessels and Platforms

For many years the Center operated two dedicated research vessels, the 40-foot R/V *Coastal Surveyor* (owned and operated by the Center) and the 34-foot R/V *Cochecho* (NOAA-owned and maintained and operated by the Center). Over the past few years, it became increasingly clear that our workhorse survey vessel, the R/V *Coastal Surveyor*, was reaching the limit of its useable service life and that the R/V *Cochecho* was not a suitable candidate to take over the role of a bathymetric sonar-mapping platform. The *Coastal Surveyor's* fiberglass hull was delaminating, and a number of drivetrain failures had been encountered, some in hazardous areas with students aboard. *Coastal Surveyor* was also very limited in her capabilities as an educational platform due to limited space in the cabin. R/V *Coastal Surveyor's* greatest strength was the versatile transducer strut that allowed for the robust installation of many different instruments, albeit that the installation of these systems was cumbersome and not without risk. Given this situation, we embarked, in 2015, on the acquisition of a new vessel that offers the same versatility for instrument deployment (in a much easier fashion), while providing better cabin space to house students, researchers, and navigation crew. We took delivery of this new vessel—the R/V *Gulf Surveyor*—in April 2016 and have been successfully using her since. Given the success and utility of the R/V *Gulf Surveyor*, the R/V *Cochecho* was retired in 2019.

### R/V *Gulf Surveyor*

(48 ft. LOA, 17 ft. beam, 4.6 ft. draft, cruising speed 14 knots)

The *Gulf Surveyor* (Figure I-11) was designed specifically for coastal hydrography and was constructed by All American Marine, Inc. (AAM) in Bellingham, WA and delivered in 2016. The overall design is based on the success of the R/V *Auk* that AAM built for NOAA in 2006, and the 45-foot R/V *David Folger* built for Middlebury College in 2012. At an overall length of 48 feet and beam of 18 feet, the catamaran vessel follows the advanced Teknikraft Design, Ltd. (Auckland, New Zealand). This includes a signature hull shape with symmetrical bow, asymmetrical tunnel, and integrated wave piercer. Main propulsion is provided by twin Cummins QSB 6.7 Tier 3 engines rated 250 bhp at 2600 rpm. Auxiliary power is supplied via a Cummins Onan 21.5kW generator. The suite of deck gear includes a hydraulic A-frame, knuckle boom crane, scientific winch, side mount sonar strut, davit, and moon pool with deployable sonar strut.

This year marked the fourth field season for the R/V *Gulf Surveyor* (RVGS). Scientists, professors, students, and industry partners utilized the vessel for work ranging from ASV support to data collection, teaching, mooring and buoy deployment and recovery, SCUBA diving and more (Figures I-12 and I-13).



Figure I-11. The R/V *Gulf Surveyor* during dive operations in the Gulf of Maine.

In an effort to continuously improve the functionality of the *Gulf Surveyor*, this year the crew:

- Designed and installed a mounting system on the aft deck for the Teledyne rapidCAST sound velocity profiler
- Designed and fabricated a towing bollard for the aft deck
- Attended technician training for the Main Engines offered by Cummins
- Modified the ground tackle system for more efficient anchoring evolutions

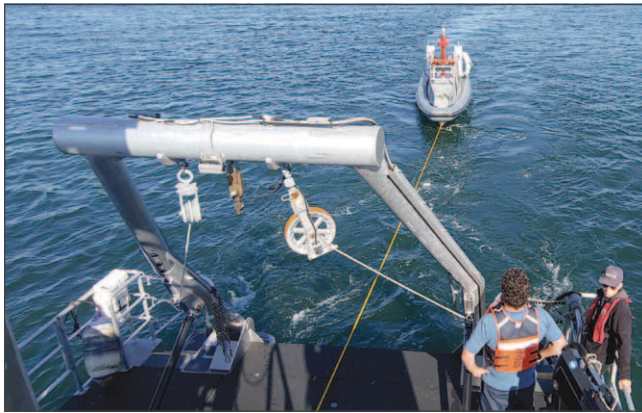

Figure I-12. Towing the DriX Autonomous Surface Vessel and launcher behind the R/V *Gulf Surveyor*.

The current list of scientific, navigation and support equipment includes:

### Scientific Equipment

- Teledyne RD Instruments WH Mariner 600 kHz Coastal Vessel Mounted DR ADCP
- Odom THP 200/24-4/20 Transducer
- Applanix POS/MV Version 5
- Trimble Trimark 3 Radio Modem
- (2) Custom Dell Precision Rack 7910
- (4) 24" Dell Monitors
- (1) SmartOnline 6000 VA Power Module
- (1) APC 3000 VA Power Module
- Dell PowerConnect 2848 Network Switch
- Peplink Max BR1 single cellular router

### Scientific Equipment on Extended Load from Industrial Partners

- EdgeTech 6205 Combined Bathymetry & Side Scan Sonar
- Teledyne Oceanscience RapidCAST Underway Sound Velocity Profiler

### Navigation Electronics

- Custom Dell Precision Rack 7910 running Rose Point Coastal Explorer
- Custom Dell Precision Tower 3420
- AXIS Q6045-S Mk II PTZ Dome Network Camera
- (2) AXIS M2014 Cameras
- FLIR M324S Stabilized Thermal Camera
- Standard Horizon VLH-3000 Loud Hailer
- Airmar 200WX Weather Station

- (2) UTEK 4-port RS-485/422 Serial to USB Converters
- (2) ICOM M-4240 Radios
- 8x8 Black Box HDMI Matrix Switch
- (4) 19" Dell Monitors
- (2) 24" Simrad MO Series Monitors

### Simrad Systems

- DX64s Radar
- Broadband 4G Radar
- AP70 Autopilot
- AC80S Autopilot Processor
- RF45X Rudder Feedback Unit
- (2) QS80 Remote Steering Control
- NSO evo2 Processor
- NSO OP40 Controller
- (2) MO19T Monitors
- GS25 GPS Antennae
- RC42 Rate Compass
- RI10 Radar Junction Box

### Garmin Systems

- GSD 25 Sonar Module
- GT51M-TH Transducer
- GPSMAP 8500 Processor
- GRID Remote Input Device
- GPSmap 840xs
- GCV 10 Transducer

Various multibeam sonar systems have been deployed efficiently through the moon pool using the custom designed strut for the *Gulf Surveyor*.



Figure I-13. Summer Hydrography students installing instrumentation on the RVGS aft deck.

**R/V Gulf Surveyor - Research and Education Operations for 2019**

Month	Days	User	Day Count
Jan	14	Jenn Dijkstra - Diving	1
Jan	23	Klein	1
Mar	8	Jenn Dijkstra - Diving	1
Mar	19	Semme Dijkstra - Class	1
Mar	25	USCG Inspection Preparation	1
Mar	26	Semme Dijkstra - Class	1
Mar	28	Crew Training	1
Apr	1	USCG Inspection	1
Apr	2, 9, 16, 23, 30	Semme Dijkstra - Class	5
Apr	10-12	Val Schmidt - ASV	3
Apr	15	Semme Dijkstra - Equipment Install	1
Apr	17-18	Casey O'Heran - UAV Survey	2
Apr	29	Andy Armstrong - Seamanship Class	1
Apr	30	Tom Weber - Class	1
May	3	Semme Dijkstra - Equipment Breakdown	1
May	6	Andy Armstrong - Seamanship Class	1
May	16	NERACOOS - Buoy Recovery	1
May	28-29	Val Schmidt - ASV	2
Jun	3-28	Summer Hydro	20
Jul	1-2	Summer Hydro	2
Jul	10-12	John Hughes Clarke	3
Jul	17	Vessel Tours	1
Jul	26-31	Weber Lines and Pipe Survey	4
Aug	1-2	Weber Lines and Pipe Survey	2
Aug	9	Casey O'Heran- UAV Survey	1
Aug	16	Crane Inspection	1
Aug	21-22	Casey O'Heran - UAV Survey	2
Aug	23-30	John Hughes Clarke	6
Sep	11	Semme Dijkstra - Class	1
Sep	12	Boston University - Class	1
Sep	13	Klein	1
Sep	16-24	Drix	7
Sep	25	Sea Robotics	1
Sep	26-30	Drix	3
Oct	1-2	Drix	2
Oct	3	Ocean Exploration Trust	1
Oct	4-15	Haulout / USCG Inspection	8
Oct	21	UNH Public Affairs	1
Oct	22-23	Jenn Dijkstra - Diving	2
Oct	25	Jenn Dijkstra - Diving	1
Oct	28	Instrumentation Install	1
Oct	30	Semme Dijkstra - Class	1
Oct	31	Instrumentation Demob	1
Nov	4	Diving - Jenn Dijkstra	1
Nov	5, 7	Casey O'Heran - UAV Survey	2
Dec	9, 17	Lisa - Sonar Test	2
Dec	19	MIT Lincoln Labs Tour	1
<b>TOTAL</b>			<b>106</b>



## ZEGO Boat—Very Shallow Water Mapping System

The Zego Boat Hydrographic Survey System is a second generation shallow water mapping research vessel (Figure I-14). The Zego Boat is a twin-hulled catamaran with 30 hp outboard motor constructed in New Zealand with durable plastic material (distributed in the U.S. by Higgs Hydrographic, Inc.). The vessel has a very shallow draft allowing it to operate in depths as little as 40-50 cm and is very stable in the presence of both waves (breaking and nonbreaking) and strong current conditions. The vessel has a front ram assembly that allows testing and integrating of equipment much easier than possible for other vessels of this size (such as waverunner-based systems like the Center’s Coastal Bathymetry Survey System; CBASS). Central to the system is an Applanix POS-MV 320 for highly accurate positioning, heading and attitude that can be integrated with a variety of multibeam echo sounders. Additional instrumentation integrated into the hulls of the vessel includes an Imagenex Delta-T MBES, Teledyne Odom Echotrac CV-100 SBES with dual frequency (200 & 24 kHz) Airmar transducer, and modular port-al for a variety of RD Instruments acoustic Doppler current profilers. System displays (Figure 1-15) are provided by two waterproof touch-screen monitors and with navigation by supported by Hypack.



Figure I-14. The JHC Zego Boat, a highly maneuverable and stable twin-hulled catamaran that is being outfitted into a state-of-the-art shallow water survey vessel with MBES, SBES, and ADCP capabilities.



Figure I-15. System displays on JHC Zego Boat.

## Autonomous Surface Vessels

### ASV BEN

In its effort to explore new and more efficient ways of collecting hydrographic data the Center has acquired a C-Worker 4 (named BEN—*Benthic Explorer and Navigator*— in honor of Capt. Ben Smith) autonomous surface vehicle from ASV Global Ltd. The C-Worker 4 is the result of a design collaboration with ASV Global with the goal of creating a platform whose sea keeping, endurance, and payload capacity are suitable for production survey operations and whose interfaces are adaptable for academic research. The vessel is approximately 4 m in length, is powered by a diesel jet drive, has a 16-hour design endurance, a 1kW electrical payload, and is outfitted

with central seachest with retractable sonar mount (Figure I-16).

An Applanix POS/MV GNSS aided IMU system has been installed to provide precise positioning and attitude, and a Kongsberg EM2040P multibeam echo-sounder, graciously provided by Kongsberg through the Center’s industrial partnership program (Appendix C), has been installed for seafloor survey. Beyond the factory sensors listed below, numerous other sensors, hardware, and software systems have been integrated into BEN. These will be discussed further under Task 11.

**ASV BEN Specifications**

**Physical**

- Length overall: 3.95 m (13')
- Beam overall: 1.58 m (5'2")
- Draft: 0.4 m approx. (1'4")
- Full load displacement: 1900 lbs (approx.)
- Central payload seachest: 80 cm x 55 cm x 34 cm
- Hull material: 5083 marine grade aluminum with fiberglass composite hatch/superstructure
- Hull color: Signal Yellow

**Propulsion**

- 30 hp Yanmar 3YM30 diesel engine
- Almarin water jet drive system with centrifugal clutch
- Hydraulic steering system
- Fuel capacity: 100 liters
- Endurance: 20 hrs at 5.5 knots (16 hrs for planning)
- Top speed: 5.5 knots (speed through water)

**Telemetry**

- 802.11 b/g Wifi (2.4GHz) (11 Bps/56Mbps) Functional range: 300 m
- 35W UHF RS232 Satel Radio Modem for low level communications and watchdog timer (watchdog timer secures fuel to engine when link is broken); functional range is unknown at this time
- Cobham COFDM IP Radio (5Mbps) Functional range: 2 nmi at 6 m base antenna height, 4 nmi at 8 m base antenna height—*installed but not currently in use*

- Iridium Short-Burst Data. Basic telemetry updates can be provided through this system at 10-20 m intervals—*installed but not currently configured*

**Electrical**

- 1.5kW 24V Alternator
- 120 Ah 24V DC Hotel Battery Bank
- 12V Starter battery
- Filtered electrical payload capacity: 1kW

**Payload and Sensors (Factory)**

- Navigation lights
- AIS Transceiver
- Lowrance marine-band radar
- Axis forward-looking color camera.
- Five color-camera array with 360 degree coverage.
- FLIR (TAU2) forward-looking infrared camera
- FLIR (AX-8) Engine Room observation camera
- Removable UW GoPro Hero7 cameras mounted to sonar plate
- Velodyne VLP-16 hi-res PUCK lidar
- Speed through water and water temperature sensor
- Electrically actuated sonar pole mount into center seachest
- Windows and Linux computers for payload and back-seat driver support
- 24V 1kW electrical payload with current monitoring and remote switching



Figure I-16. CWorker-4 model vehicle BEN (Bathymetric Explorer and Navigator) operating in the vicinity of Portsmouth Harbor, NH.



### Teledyne Oceansciences Z-boat, Seafloor Systems Echoboat, and Hydrnalix EMILY Boat

The Center has also been given a Teledyne Oceansciences “Z-Boat,” and a Seafloor Systems “Echo-boat,” each donated under the Center’s industrial partnership program (Figure I-17). In addition NOAA has provided a Hydrnalix EMILY boat to add to the Center’s fleet (not shown). The Z-boat is equipped with an Odom CV100 single beam echo sounder and Trimble GPS and heading system. The Echoboat has been outfitted with an ArduPilot based control system with commodity GPS and compass for navigation. The Emily boat is being outfitted with an Emlid Navio2 based control system with integral GPS and dual IMU. The Center has written interfaces to all of these vessels allowing them to be driven from the Center’s “Project 11” robotics framework, providing a convenient platform for shallow water survey and research into new behaviors and levels of autonomy for ASVs. These vessels have proven to be a very useful platform for prototyping and testing autonomous control algorithms (see Task 11).



Figure I-17. Small autonomous surface vessels used by the Center to develop autonomous command and control algorithms: Seafloor Systems’ “Echoboat” (left), Hydrnalix “Emily Boat” (middle), and Teledyne Oceansciences’ “Z-Boat” (right).

### DriX Autonomous Surface Vessel

In a collaborative effort with iXblue, the Center, and NOAA, DriX Autonomous Surface Vessels have been housed and supported by the Center since the December 2018. The DriX is a 7.7m long, wave-piercing, composite composition vehicle, capable of meeting NOAA’s hydrographic survey specifications at speeds exceeding 10 kts. In addition, the DriX boasts an endurance of seven 24-hour days at 7 knots, providing a long-endurance capability not possible by most other vehicles of its size. The Center has facilitated installation of an EM2040 multibeam system, and a Kongsberg MBR long-range radio for vehicle evaluation and testing both at the Center and in trials aboard NOAA vessels. See Task 11 for further details.



Figure I-18. The iXblue DriX autonomous surface vehicle in its Launch and Recovery System (LARS). From left: being lowered into the water alongside the UNH Marine Pier in New Castle, NH; undergoing testing in Portsmouth Harbor, NH with the R/V Gulf Surveyor; and being launched over the side of the NOAA Ship Thomas Jefferson in Norfolk, VA.



**DriX Specifications**

**Physical**

- Length overall: 7.7 m
- Beam overall: 0.8 m
- Draft: 2.0 m

**Propulsion**

- Engine: 37 Hp Nanni Diesel
- Prop-driven
- Fuel capacity: 250 liters
- Endurance: Seven 24-hour days at 7 knots
- Top speed: >12 knots

**Electrial**

- 24V system
- 900 W AC for survey payload

**Telemetry**

- Kongsberg marine broadband radio
- Wifi

**Payload**

- Kongsberg EM2040
- iXblue PHINS AHRS with Septentrio GPS (LARS)

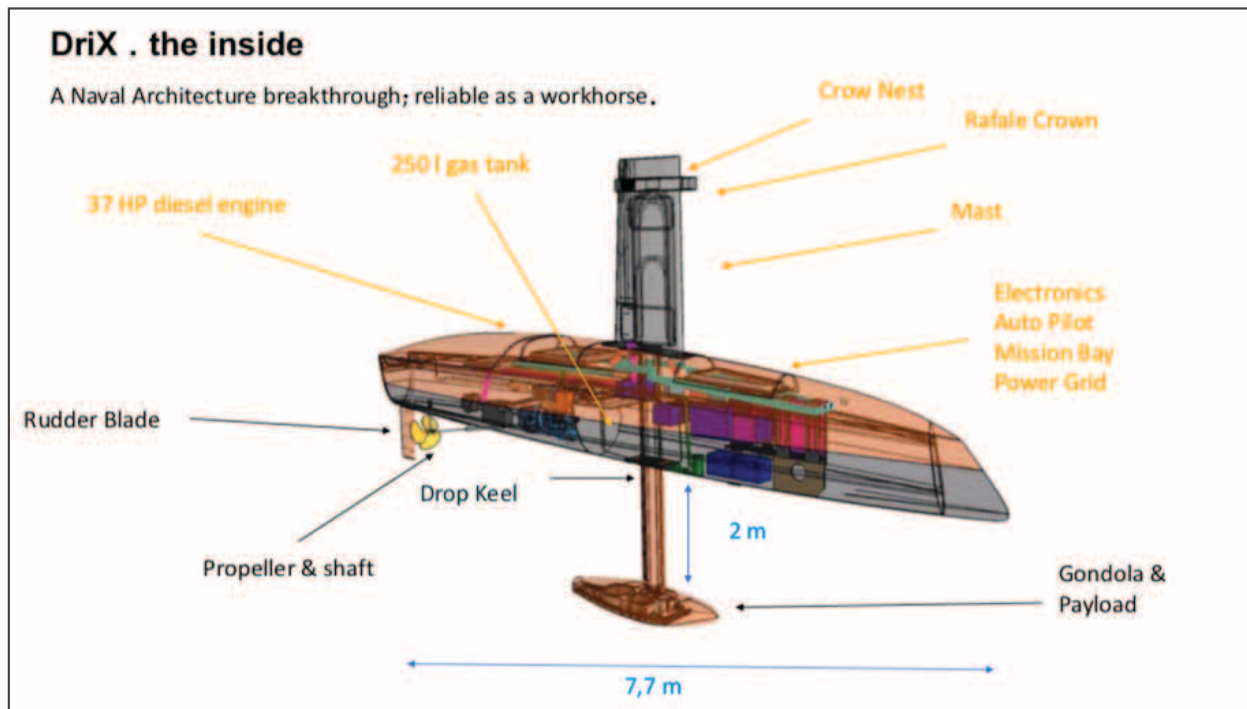

Figure I-19. Schematic of the iXblue DriX autonomous surface vehicle.

## Status of Research: January–December 2019

The Federal Funding Opportunity (FFO) for the current grant, NA15NOS4000200, competitively awarded to the Center for the period of 2016-2020, defined four programmatic priorities:

### Innovate Hydrography

#### Transform Charting and Change Navigation

#### Explore and Map the Continental Shelf

#### Develop and Advance Hydrographic and Nautical Charting Expertise

Under these, 14 specific research requirements were prescribed (our short name for each research requirement follows the description, highlighted in bold):

### Innovate Hydrography

1. Improvement in the effectiveness, efficiency, and data quality of acoustic and LIDAR bathymetry systems, their associated vertical and horizontal positioning and orientation systems, and other sensor technology for hydrographic surveying and ocean and coastal mapping, including autonomous data acquisition systems and technology for unmanned vehicles, vessels of opportunity, and trusted partner organizations— **Data Collection**.
2. Improvement in technology and methods for more efficient data processing, quality control, and quality assurance, including the determination and application of measurement uncertainty, of hydrographic and ocean and coastal mapping sensor and ancillary sensor data, and data supporting the identification and mapping of fixed and transient features of the seafloor and in the water column—**Data Processing**.
3. Adaption and improvement of hydrographic survey and ocean mapping technologies for improved coastal resilience and the location, characterization, and management of critical marine habitat and coastal and continental shelf marine resources—**Tools for Seafloor Characterization, Habitat, and Resources**.
4. Development of improved tools and processes for assessment and efficient application to nautical charts and other hydrographic and ocean and coastal mapping products of data from both authoritative and non-traditional sources—**Third Party and Non-traditional Data**.

### Transform Charting and Change Navigation

1. Development of improved methods for managing hydrographic data and transforming hydrographic data and data in enterprise GIS databases to electronic navigational charts and other operational navigation products. New approaches for the application of GIS and spatial data technology to hydrographic, ocean, and coastal mapping, and nautical charting processes and products—**Chart Adequacy and Computer-Assisted Cartography**.
2. Development of innovative approaches and concepts for electronic navigation charts and for other tools and techniques supporting marine navigation situational awareness, such as prototypes that are real-time and predictive, are comprehensive of all navigation information (e.g., charts, bathymetry, models, currents, wind, vessel traffic, etc.), and support the decision process (e.g., under-keel clearance management)—**Comprehensive Charts and Decision Aids**.

3. Improvement in the visualization, presentation, and display of hydrographic and ocean and coastal mapping data, including four-dimensional high resolution visualization, real-time display of mapping data, and mapping and charting products for marine navigation as well as coastal and ocean resource management and coastal resilience —**Visualization**.

### Explore and Map the Continental Shelf

1. Advancements in planning, acquisition, understanding, and interpretation of continental shelf, slope, and rise seafloor mapping data, particularly for the purpose of delimiting the U.S. Extended Continental Shelf—**Extended Continental Shelf**.
2. Development of new technologies and approaches for integrated ocean and coastal mapping, including technology for creating new products for non-traditional applications and uses of ocean and coastal mapping—**Ocean Exploration Technologies and IOCM**.
3. Improvements in technology for integration of ocean mapping with other deep ocean and littoral zone technologies such as remotely operated vehicles and telepresence-enhanced exploration missions at sea—**Telepresence and ROVs**.

### Develop and Advance Hydrographic and Nautical Charting Expertise

1. Development, maintenance, and delivery of advanced curricula and short courses in hydrographic and ocean mapping science and engineering at the graduate education level—leveraging to the maximum extent the proposed research program, and interacting with national and international professional bodies—to bring the latest innovations and standards into the graduate educational experience for both full-time education and continuing professional development—**Education**.
2. Development, evaluation, and dissemination of improved models and visualizations for describing and delineating the propagation and levels of sound from acoustic devices including echo sounders, and for modeling the exposure of marine animals to propagated echo sounder energy—**Acoustic Propagation and Marine Mammals**.
3. Effective delivery of research and development results through scientific and technical journals and forums and transition of research and development results to an operational status through direct and indirect mechanisms including partnerships with public and private entities—**Publications and R2O**.
4. Public education and outreach to convey the aims and enhance the application of hydrography, nautical charting, and ocean and coastal mapping to safe and efficient marine navigation and coastal resilience—**Outreach**.

These programmatic priorities and research requirements are not radically different from those prescribed under earlier grants and thus much of the research being conducted under the 2016-2020 grant represents a continuation of research. Several of the requirements, particularly those involved with cartographic issues and marine mammals represent new directions for the lab.

To address the four programmatic priorities and 14 research requirements, the Center divided the research requirements into themes and sub-themes, and responded with 60 individual research projects or research tasks, each with an identified investigator or group of investigators as the lead (Figure I-20).

These research tasks are constantly being reviewed by Center management and the Program Manager and are adjusted as tasks are completed, merge as we learn more about the problem, or are modified due to changes



PROGRAMMATIC PRIORITIES	RESEARCH REQUIREMENTS	THEMES	SUB-THEMES	PROJECTS	POC	REF. #	
INNOVATE HYDROGRAPHY	DATA COLLECTION	SENSOR CALIBRATION AND SONAR DESIGN	SONAR	Tank Calibrations	Lanzoni	1	
				PMBS Evaluation	Schmidt	2	
				Circular Array Bathymetric Sonar	Weber	3	
				Synthetic Aperture Sonar	Weber and Lyons	4	
				LIDAR	Eren	5	
		<del>SOUND SPEED</del>	<del>Pe'eri</del>	<del>6</del>			
		SENSOR INTEGRATION and REAL-TIME QA/QC	Deterministic Error Analysis/Integration Error	Hughes Clarke	7		
			Data Performance Monitoring	Calder	8		
			Auto Patch Test Tools	Calder	9		
			Nav Processing and Boot Camp	Schmidt	10		
			Add-on Sensors and Hydro Applications	Schmidt	11		
	DATA PROCESSING	TRUSTED PARTNER DATA	ALGORITHMS and PROCESSING	Trusted Hardware	Calder	12	
				CHRT and Expanded Processing Methods	Calder	13	
		FIXED AND TRANSIENT WATERCOLUM AND SEAFLOOR FEATURES	SEAFLOOR	Multi-Detect Processing	Weber and Calder	14	
				Data Quality and Survey Validation Tools	Calder	15	
				Phase Measuring Bathymetric Sonar Processing	Schmidt	16	
				Automatic Processing for Topo-Bathymetric LIDAR	Calder	17	
				Watercolumn Target Detection	Weber	19	
				Watercolumn and Seafloor Features	Calder and Masetti	18	
		SEAFLOOR CHARACTERIZATION HABITAT and RESOURCES	COASTAL AND CONTINENTAL SHELF RESOURCES	SONAR	Mapping Gas and Leaky Pipelines in Watercolumn	Weber	20
					Identification of Marine Mineral Deposits	Ward	21
	SEAFLOOR CHARACTERIZATION		SONAR	GeoCoder/ARA	Masetti	22	
				Singlebeam Characterization	Lippmann	23	
				Multi-frequency Seafloor Backscatter	Hughes Clarke and Weber	24	
			LIDAR and IMAGERY	Lidar Waveform Extraction	Eren and Parrish	25	
				<del>Object Based Image Analysis</del>	<del>J. Dijkstra</del>	<del>26</del>	
			CRITICAL MARINE HABITAT	Video Mosaics and Segmentation Techniques	Rzhanov	27	
	<del>Margin-wide Habitat Analysis</del>			<del>Mayer, J. Dijkstra, and Mosher</del>	<del>28</del>		
	COASTAL RESILIENCE and CHANGE DETECTION		COASTAL RESILIENCE and CHANGE DETECTION	Shoreline Change	Eren	29	
				Seabed Change	Hughes Clarke	30	
				Change in Benthic Habitat and Restoration	J. Dijkstra	31	
				Marine Coastal Decision Support Tools	Butkiewicz and Vis Lab	32	
				Temporal Stability of the Seafloor	Lippmann and Hughes Clarke	33	
		Assessment of Quality of 3rd Party Data		Calder	34		
	THIRD PARTY and NON-TRADITIONAL DATA	THIRD PARTY DATA	NON-TRADITIONAL DATA SOURCES	Assessment of ALB data	Eren	35	
				ALB			
SDB							
Development of Techniques for Satellite Derived Bathymetry				Pe'eri	36		
TRANSFORM CHARTING AND NAVIGATION	COMPREHENSIVE CHARTS AND DECISION AIDS	CHART ADEQUACY and COMPUTER-ASSISTED CARTOGRAPHY	Managing Hydrographic Data and Automated Cartography	Calder and Kastrisios	37		
			Chart Adequacy and Re-survey Priorities	Calder, Kastrisios, and Masetti	38		
			Hydrographic Data Manipulation Interfaces	Calder, Hughes Clarke, Butkiewicz, and Ware	39		
	VISUALIZATION AND RESOURCE MANAGEMENT	GENERAL ENHANCEMENT OF VISUALIZATION	Information Supporting Situational Awareness	Ware, Sullivan, and Vis. Lab.	40		
			Under-keel Clearance, Real-time and Predictive Decision Aids	Calder and Vis. Lab.	41		
			Ocean Flow Model Distribution and Accessibility	Sullivan	42		
	GENERAL ENHANCEMENT OF VISUALIZATION	GENERAL ENHANCEMENT OF VISUALIZATION	Textual Nautical Information	Sullivan	43		
			Augmented Reality Supporting Charting and Nav	Butkiewicz	44		
Tools for Visualizing Complex Ocean Data			Ware, Sullivan, and Vis. Lab.	45			
EXPLORE AND MAP THE EXTENDED CONTINENTAL SHELF	EXTENDED CONTINENTAL SHELF	EXTENDED CONTINENTAL SHELF	Lead in Planning, Acquiring and Processing ECS	Gardner, Mosher, and Mayer	47		
			Extended Continental Shelf Taskforce	Mosher, Gardner, and Mayer	48		
			<del>Best Approaches for Legacy Data Delineation Techniques</del>	<del>Mosher, Gardner, and Mayer</del>	<del>49</del>		
	OCEAN EXPLORATION	OCEAN EXPLORATION	ECS Data for Ecosystem Management	Mayer, Mosher, and J. Dijkstra	50		
			Potential of MBES Data to Resolve Oceanographic Features	Weber, Mayer, and Hughes Clarke	51		
	TELEPRESENCE AND ROVS	TELEPRESENCE AND ROVS	Immersive Live Views from ROV Feeds	Ware	52		
	HYDROGRAPHIC EXPERTISE	ACOUSITC PROPAGATION AND MARINE MAMMALS	ACOUSITC PROPAGATION AND MARINE MAMMALS	Revisit Education Program	Hughes Clarke and S. Dijkstra	53	
Modelling Radiation Patterns of MBES				Weber and Lurton	54		
Web-based Tools for MBES Propagation				Johnson and Arsenaault	55		
PUBLICATIONS AND R2O OUTREACH		PUBLICATIONS AND R2O OUTREACH	Impact of Sonars on Marine Mammals	Miksis-Olds	56		
			Continue Publication and R2O Transitions	Mayer	57		
			Expand Outreach and STEM Activities	Hicks-Johnson and Mitchell	58		
DATA MANAGEMENT	EXTENDED DATA MANAGEMENT PRACTICE	EXTENDED DATA MANAGEMENT PRACTICE	Data Sharing, ISO19115 Metadata	Johnson and Chadwick	59		
			Enhanced Web Services for Data Management	Johnson	60		

Figure I-20. Original breakdown of Programmatic Priorities and Research Requirements of FFO into individual projects or tasks with modifications made after year one. Red text indicates a change of responsible PI.

in personnel (e.g., the loss of Shachak Pe'eri from the Center faculty when he became a NOAA employee and moved to Silver Spring, or the loss of David Mosher due to his election to the Committee on the Limits of the Continental Shelf, and most recently the loss of Firat Eren in his return to Turkey). In response to these changes we have made the following adjustments to our research tasks in consultation with the NOAA Program Manager:

1. We have de-emphasized the tasks associated with Phase Measuring Bathymetric Systems (Tasks 2 and 16) in response to limited use of these systems by NOAA OCS. We will monitor future developments with these systems and re-evaluate if necessary.
2. The lidar tasks (Task 5 and 29) will be placed on hold with the departure of Firat Eren. We are searching for a replacement but, in the meantime, will continue our collaboration with Chris Parrish at OSU with respect to lidar issues, and Brian Calder and Kim Lowell are working on lidar data analysis (Task 17), with impact on Tasks 34 and 35).

3. With the departure of Shachak Pe'eri, Task 6 (Distributed Temperature Sensing) was dropped from our task list. This effort is continuing through an SBIR with NOAA.
4. We have completed the Autonomous Vehicle Boot Camp efforts (Task 10) with several successful Boot Camps.
5. We have greatly expanded our Autonomous Surface Vehicles efforts (Task 11) with upgrades to the CWorker-4 (BEN) and the arrival of the DriX autonomous surface vessel.
6. Calder has replaced Pe'eri as the lead for Task 17—Processing for Topo-Bathy Lidar.
7. With the completion of early work on single beam seafloor characterization (Task 23), this effort has been de-emphasized given limited use by OCS.
8. Tasks 26 (Single Beam Seafloor Characterization) and 28 (Object-Based Image Analysis) have been deemed unproductive and the resources assigned to Tasks 33 and 31 respectively, with the approval of the Program Manager.
9. Task 28 (Margin-wide Habitat Analysis) has merged with Task 50 (ECS Data for Ecosystem Management) since they are basically two parts of the same task. For reporting purposes, 28 will be dropped and 50 used instead.
10. The efforts of Task 29 (Shoreline Change) have been picked up by NOAA OCS.
11. Coincident with the departure of Pe'eri, the research associated with Task 36 (Development of Techniques for Satellite-Derived Bathymetry) was completed, and the project is in transition to operations at NOAA.
12. Task 40 (Visualizing Currents Waves and Weather) has been combined with Task 42 (Ocean Flow Modeling Visualization) and will just be referred to as Task 40.
13. Task 45 (Tools for Visualizing Complex Ocean Data) has been combined with Task 46 (New Interaction Techniques) and will just be referred to as Task 45.

As we complete the fourth year of effort, the updated tasks are presented in Figure I-21. Note that we have chosen not to renumber the tasks so that there is continuity of reporting throughout the duration of the grant. This and subsequent progress reports for Grant NA15NOS4000200 will address progress on a task by task basis. It must be noted, however, that the grant extends over five years (2016-2020) and there will not necessarily be progress on every task every year. It should also be noted that, as our research develops, we may find that some tasks do not warrant continuation while new directions or combinations of efforts may evolve that lead to changes in emphasis or the evolution of new tasks within the same scope of effort. This will be essential to allow innovation to flourish under this cooperative agreement.

PROGRAMMATIC PRIORITIES	RESEARCH REQUIREMENTS	THEMES	SUB-THEMES	PROJECTS	POC	REF. #	TRL			
INNOVATE HYDROGRAPHY	DATA COLLECTION	SENSOR CALIBRATION AND SONAR DESIGN	SONAR	Tank Calibrations	Lanzoni	1	3			
				PMBS Evaluation	Schmidt	2	4			
				Circular Array Bathymetric Sonar	Weber	3	3			
			Synthetic Aperture Sonar	Weber and Lyons	4	2				
			Lidar Simulator	Eren	5	3				
			Distributed Temperature Sensing	Eren	6	X				
		LIDAR	SENSOR INTEGRATION and REAL-TIME QA/QC	Deterministic Error Analysis/Integration Error	Hughes Clarke	7	4			
				Data Performance Monitoring	Calder	8	3			
				Auto Patch Test Tools	Calder	9	2			
		SOUND SPEED	INNOVATIVE PLATFORMS	AUVs	Schmidt	10	3			
				ASVs	Schmidt	11	2			
				Add-on Sensors and Hydro Applications	Calder	12	4			
	DATA PROCESSING	ALGORITHMS and PROCESSING	TRUSTED PARTNER DATA		CHRT and Expanded Processing Methods	Calder	13	5		
			Multi-Detect Processing	Weber and Calder	14	5				
			Data Quality and Survey Validation Tools	Calder	15	4				
			Phase Measuring Bathymetric Sonar Processing	Schmidt	16	2				
			Automatic Processing for Topo-Bathymetric LIDAR	Calder	17	4				
			Hydro-significant Object Detection	Calder and Masetti	18	4				
			FIXED AND TRANSIENT WATERCOLUM AND	SEAFLOOR WATER COLUMN	Watercolumn Target Detection	Weber	19	6		
					Mapping Gas and Leaky Pipelines in Watercolumn	Weber	20	7		
			SEAFLOOR CHARACTERIZATION, HABITAT and RESOURCES	COASTAL AND CONTINENTAL SHELF RESOURCES	Tools for Identification of Marine Mineral Deposits		Ward	21	2	
					SEAFLOOR CHARACTERIZATION	SONAR	GeoCoder/ARA	Masetti	22	4
							Singlebeam Characterization	Lippmann	23	1
							Multi-frequency Seafloor Backscatter	Hughes Clarke and Weber	24	4
	LIDAR and IMAGERY	Lidar Waveform Extraction				Parrish	25	2		
		Object Based Image Analysis				J. Dijkstra	26	X		
		Video Mosaics and Segmentation Techniques		Rhanov		27	5			
	CRITICAL MARINE HABITAT	Margin-wide Habitat Analysis		Mayer and J. Dijkstra	28	1				
		Shoreline Change		Eren	29	2				
		Seabed Change		Hughes Clarke	30	2				
		Change in Benthic Habitat and Restoration		J. Dijkstra	31	7				
		Marine Coastal Decision Support Tools		Butkiewicz and Vis Lab	32	2				
		Temporal Stability of the Seafloor	Lippmann	33	2					
	THIRD PARTY and NON-TRADITIONAL DATA	THIRD PARTY DATA		Assessment of Quality of 3rd Party Data	Calder	34	3			
		NON-TRADITIONAL DATA SOURCES	ALB	Assessment of ALB data	Eren	35	1			
				Development of Techniques for Satellite Derived Bathymetry	Eren	36	X			
CHART ADEQUACY and COMPUTER-ASSISTED CARTOGRAPHY				Managing Hydrographic Data and Automated Cartography	Calder and Kastrisios	37	3			
		Chart Adequacy and Re-survey Priorities	Calder, Kastrisios, and Masetti	38	3					
		Hydrographic Data Manipulation interfaces	Calder, Hughes Clarke, Butkiewicz, and Ware	39	4					
	COMPREHENSIVE CHARTS AND DECISION AIDS	INFORMATION SUPPORTING SITUATIONAL AWARENESS	Currents Waves and Weather	Ware, Sullivan, and Vis. Lab.	40	4				
			Under-keel Clearance, Real-time and Predictive Decision Aids	Calder and Vis. Lab.	41	3				
			Ocean Flow Model Distribution and Accessibility	Sullivan	42	7				
VISUALIZATION AND RESOURCE MANAGEMENT	GENERAL ENHANCEMENT OF VISUALIZATION	Textual Nautical Information	Sullivan	43	7					
		Augmented Reality Supporting Charting and Nav	Butkiewicz	44	4					
		Tools for Visualizing Complex Ocean Data	Ware, Sullivan, and Vis. Lab.	45	4					
EXPLORE AND MAP THE EXTENDED CONTINENTAL SHELF	EXTENDED CONTINENTAL SHELF	Lead in Planning, Acquiring and Processing ECS	Gardner and Mayer	47	8					
		Extended Continental Shelf Taskforce	Gardner and Mayer	48	8					
		Best Approaches for Legacy Data: Delineation Techniques	Gardner and Mayer	49	5					
	OCEAN EXPLORATION	ECS Data for Ecosystem Management	Mayer and J. Dijkstra	50	3					
		Potential of MBES Data to Resolve Oceanographic Features	Weber, Mayer, and Hughes Clarke	51	2					
		Immersive Live Views from ROV Feeds	Ware	52	2					
HYDROGRAPHIC EXPERTISE	EDUCATION	Revisit Education Program	Hughes Clarke, Kastrisios and S. Dijkstra	53	N/A					
	ACOUSTIC PROPAGATION AND MARINE MAMMALS	Modelling Radiation Patterns of MBES	Weber and Lurton	54	6					
		Web-based Tools for MBES Propagation	Johnson and Arsenault	55	2					
		Impact of Sonars on Marine Mammals	Miksis-Olds	56	3					
	PUBLICATIONS AND R2O OUTREACH	Continue Publication and R2O Transitions	Mayer	57	N/A					
		Expand Outreach and STEM Activities	Hicks-Johnson and Mitchell	58	N/A					
DATA MANAGEMENT	EXTENDED DATA MANAGEMENT PRACTICE		Data Sharing, ISO19115 Metadata	Johnson	59	4				
			Enhanced Web Services for Data Management	Johnson	60	6				

Figure I-21. Current breakdown of Programmatic Priorities and Research Requirements of FFO into individual projects or tasks.



## Programmatic Priority 1: Innovate Hydrography

### Research Requirement 1.A: Data Collection

**FFO Requirement 1.A.** "Improvement in the effectiveness, efficiency, and data quality of acoustic and LIDAR bathymetry systems, their associated vertical and horizontal positioning and orientation systems, and other sensor technology for hydrographic surveying and ocean and coastal mapping, including autonomous data acquisition systems and technology for unmanned vehicles, vessels of opportunity, and trusted partner organizations."

#### THEME: 1.A.1: Sensor Calibration and Innovative Sensor Design

##### Sub-Theme: SONAR

**TASK 1:** *Continue to develop approaches for **sonar calibration** that can be transferred to the fleet rather than require each sonar to be brought to the tank. PI: Carlo Lanzoni*

##### Project: Sonar Calibration Facility

**JHC Participants:** Carlo Lanzoni, Tom Weber, Paul Lavoie, Michael Smith, John Hughes Clarke

**Other Participants:** Various Industrial Sponsors

The Center continues to maintain a state-of-the-art sonar calibration facility. This facility resides in the Center for Ocean Engineering's large engineering tank, measuring 18 m x 12 m x 6 m (LWD). The facility is equipped with a rigid (x,y)-positioning system, a computer-controlled rotor with better than 0.1 degree accuracy, and a custom-built data acquisition system. Added upgrades to the tank made by the Center include continuous monitoring of temperature and sound speed, a computer-controlled standard-target positioning system (z-direction), and the capability for performing automated 2D beam-pattern measurements. This facility is routinely used by Center researchers for now-routine measurements of beam pattern, driving-point impedance, transmitting voltage response (TVR), and receive sensitivity (RS). In 2019, measurements were made of (Figure 1-1):

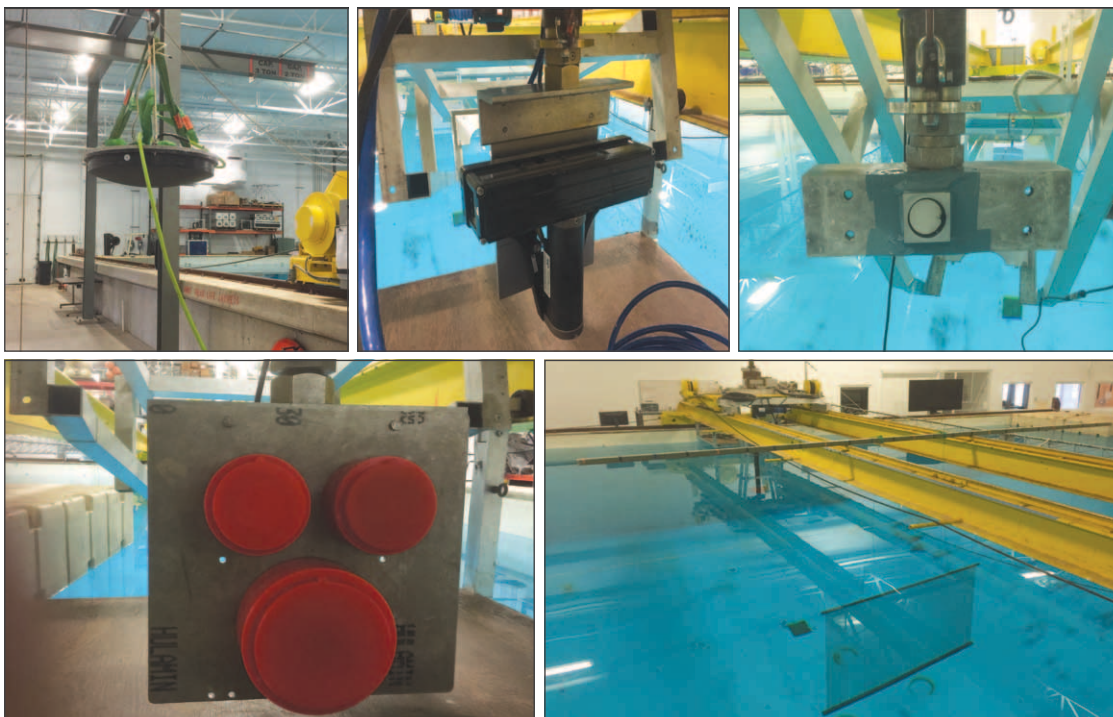

Figure 1-1. Tests in the acoustic tank in 2019. Top Left: MSI LF CBT; Top Center: Reson T50-P; Top Right: Custom-built transducer; Bottom Left: Simrad split-beam echosounders; Bottom Right: Standard chain target.

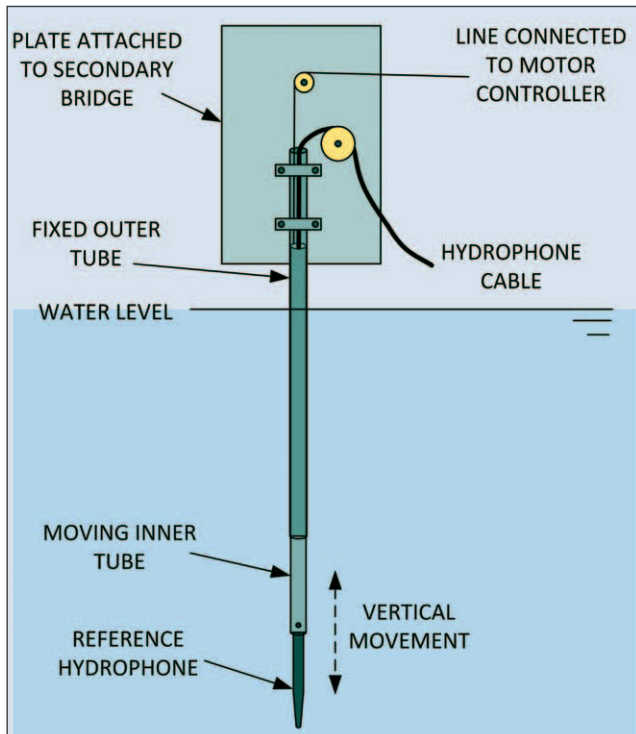

Figure 1-2. Vertical position control of reference hydrophone.

1. Beam pattern of an MSI LF CBT transducer and characterization of acoustic backscattering from gas bubbles, by Alex Padilla and Carlo Lanzoni.
2. Source level, receive gain, and beam pattern calibration of a RESON T50-P, by Tom Weber, Gorm Wendelboe (RESON), Carlo Lanzoni, and Michael Smith.

3. Performance evaluation of three Simrad split-beam echosounders (ES70-7C, ES120-7C, and ES200-7C), by John Hughes Clarke, Ivan Guimaraes, and Leonardo Araujo.
4. Acoustic calibration of a standard chain target, by Carlo Lanzoni, Tom Weber, and Alex Padilla.
5. Impedance, TVR, RS, transmit beam pattern, and receive beam pattern of a small custom-built electro-acoustic transducer, by Carlo Lanzoni and Lisa Sulmasy.

One important addition to the acoustic tank equipment this year is the custom-built vertical positioning system for the standard reference hydrophone (Reson TC4034). This new device is coupled with the main rotor allowing for automated decoupled 2D transmit and receive beam pattern measurements with accuracy better than 0.1 degrees and reducing the necessary oversight during calibration (Figure 1-2).

### Evaluation of Calibration Approaches

The quantitative use of multibeam echosounder (MBES) backscatter is typically limited due to the lack of calibration for the directivity and sensitivity of the echosounder. While this makes a calibrated system a desirable goal, MBES backscatter calibration is an often-difficult task even in the best of scenarios. In May 2019 a Teledyne Reson Seabat T50-P multibeam echosounder was sent to the Center for backscatter intensity calibration as part of a collaboration with the Applied Physics Lab of the University of Washington and Teledyne Reson. The unrestricted use of

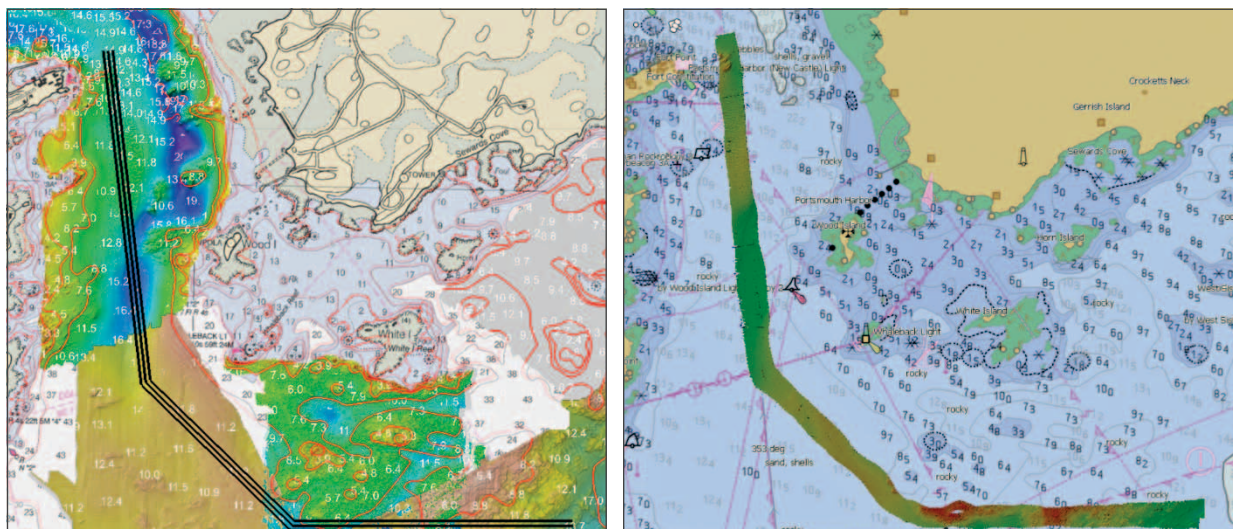

Figure 1-3. Left: Line plan for the 2019 NEWBEX project. Lines have been overlain on top of existing high-resolution bathymetry for the region. Right: Collected bathymetry at 300 kHz.

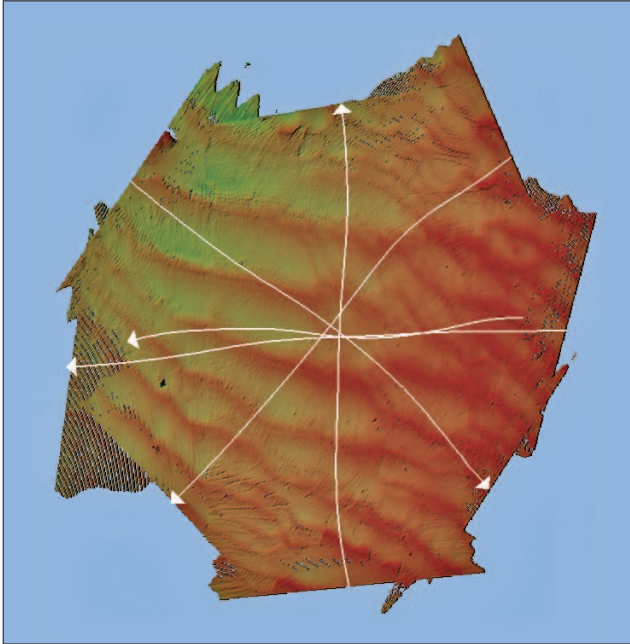

Figure 1-4. The bathymetry of a star pattern with the track lines overlain. The backscatter data collected from these patterns will be used to determine if there is an azimuthal dependence to the collection of backscatter.

the Reson T50-P for calibration purposes presented a unique opportunity to try a number of different calibration methodologies, and compare/contrast the relative merits of each method. The acoustic tank in Chase Ocean Lab was utilized to perform a full suite of calibration tests on the MBES at frequencies ranging from 200 kHz to 400 kHz. Standard tests such as the gain linearity and standard target sphere calibration were conducted. A newer method tested was the extended target methodology (Heaton et al. 2017). This method utilizes a 2m by 2m jack-chain target which better approximates the scattering response of the seafloor. The extended target method is advantageous because it provides an end-to-end calibration of the system, greatly reducing the calibration time.

As part of the Reson T50-P calibration, the Center used the Reson Seabat T50-P to collect data for the NEWBEX project in July of 2019. The NEWBEX line is a standard line that was established in 2012. The line extends from the mouth of the Piscataqua River in Portsmouth, NH to two miles southeast of Gerrish Island, ME. Backscatter and bathymetry data has been collected along the line almost yearly and as part of the Center's hydrographic field course. The T50-P in-tank calibration presented a unique opportunity to compare the efficacy of the standard line methodology to in-tank calibration results. For this experiment,

an extensive bathymetry and backscatter dataset was collected along the NEWBEX line. A full mobilization and patch test of the system were conducted prior to the survey. The survey was composed of the three lines with over 50% swath overlap over the shallowest point for the 140° swath (Figure 1-3). The lines were run repeatedly for a number of frequencies (200 kHz to 400 kHz) in 50 kHz increments. In addition to the survey lines, a number of star patterns were collected over the varying known bottom types along the NEWBEX line. These star patterns (Figure 1-4) were designed to test the azimuthal dependence of the backscatter response, which has been observed before in other areas and systems. In addition to comparing the results of this work to the results of the calibration tests of the prior project, a long term goal for this dataset is to serve as a qualified, multi-purpose dataset for backscatter studies. Processing will begin in the coming year.

### Innovative Field Calibration Procedures

We continue to work toward developing approaches for an absolute field-calibration using standard target spheres (e.g., tungsten carbide ball bearings). This approach has been previously demonstrated by Lanzoni, using a split-beam echo sounder to aid in sphere localization within the MBES reference frame. One of the challenges of this approach is in the mechanical deployment of the sphere which, due to the wide swath of the MBES, required very large and cumbersome outriggers. To address this concern, the next development has included the design, construction, and testing of a more portable positioning mechanism for the calibration sphere. This approach uses a sphere suspended in the water column from monofilament lines connected to two remote-controlled thrusted buoys that move continuously to position the acoustic target throughout the entire swath of the MBES sonar systems.

Each of the two buoys employs thrusters controlled via radio frequency from a command and control system on the vessel. A system to provide buoy position (relative to the vessel) in real-time has been designed and prototyped using wireless radio transceivers for real-time location with a precision of 10 cm at ranges of up to 300 m. In the prototype system, four radio transceiver modules fixed on the vessel (base stations) exchange signals with each of the two radio transceiver modules installed on the buoys (tags) to obtain 2D coordinates for each buoy using trilateration (Figure 1-5).



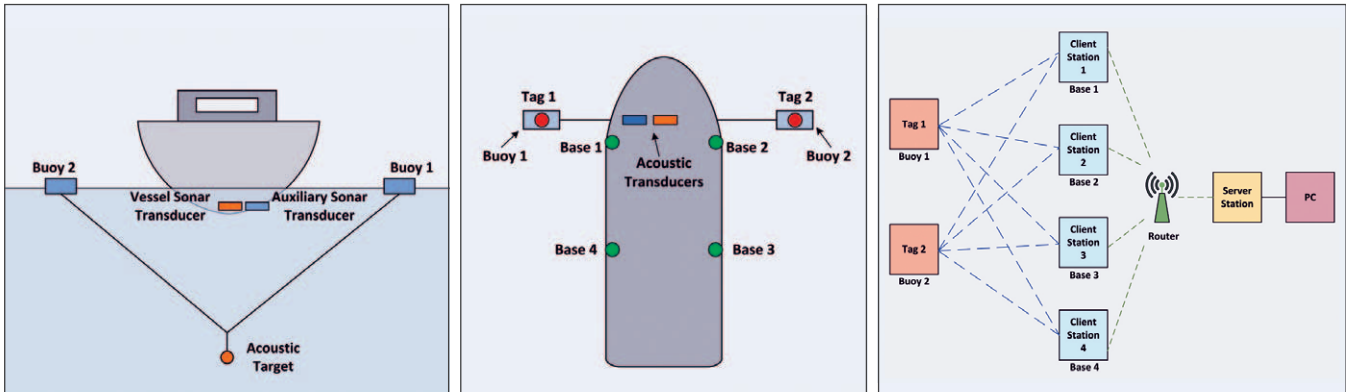

Figure 1-5. Left: Target positioning mechanism using remote-controlled buoys; Center: Location system setup on vessel; Right: Real time location of tagged buoys using radio transceivers diagram.

A first buoy prototype was built and tested in the acoustic tank. The initial tests verified proper working of the electronic control system. However, the tests also revealed the difficulties in maintaining position stability on a small rounded float using two thrusters to control movement and positioning. This year, a second floating platform using a catamaran shape was designed and built to improve position and movement stability. This new buoy prototype performed well with good stability during the tests in the acoustic tank. The buoy navigation control is based on the Ardupilot open source platform and employs a conventional remote control to provide commands to the onboard flight controller. A ground control station (an application installed on a personal computer) connects to the flight controller via radio telemetry to command and monitor the buoy behavior (Figure 1-6).

A long-range (LoRa) radio link was developed to feed the X-Y coordinate values of each buoy from the control station on the vessel to the flight controllers installed on the two buoys. This radio link is being incorporated to the scheme to provide the necessary position feedback for the control system. Critical to the design is the fact that the buoys are small, hand deployable, and easy to carry on survey launches. If successful, this absolute calibration procedure will be compatible with the standard line survey procedures, allowing an absolute calibration to be conducted for a single system in a survey area, and for this absolute calibration to be carried to other MBES systems via a standard line relative calibration.

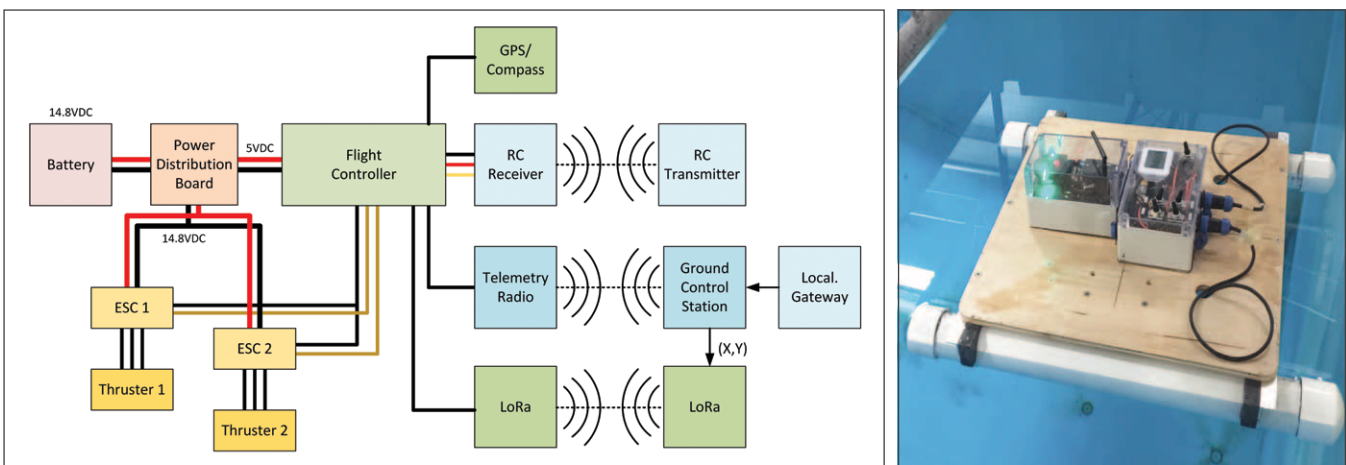

Figure 1-6. Remote controlled thrusted buoy. Left: Block diagram; Right: Second buoy prototype tested in the acoustic tank.

**TASK 2:** Evaluate the capabilities and limitations of the current and future generation of *Phase Measuring Bathymetric Sonars (PMBS)* in order to better understand their potential as hydrographic tools. PI: **Val Schmidt**

**Project: Capabilities and Limitations of PMBS**

**JHC Participant:** Val Schmidt

Phase-measuring bathymetric sidescan (PMBS) sonar systems provide the promise of co-incident bathymetry and high-resolution sidescan imagery, with an increased swath width over traditional single-head multibeam echosounders. Early results indicated continued issues and limitations with PMBS with respect to hydrographic quality data and advantage over other methods, and thus the effort has been de-emphasized within the context of the grant. Nonetheless, Schmidt continues to keep abreast of progress with the systems and continues to work with manu-

facturers and software developers to increase their capability and suitability for hydrographic applications.

This current year, Schmidt has been interacting with researchers at the University of Connecticut who are conducting ongoing surveys with Geoswath PMBS systems in Long Island Sound under sponsorship with NOAA's National Centers for Coastal and Ocean Science. Efforts are on the production of hydrographic quality data products from habitat focused surveys.

**TASK 3:** *Cylindrical Array Bathymetric Sonar.* PI: **Tom Weber**

**Project: CABS**

**JHC Participants:** Tom Weber, Glen Rice, and Jonathan Hamel

**Other Participants:** Kongsberg Maritime

Acoustic seafloor mapping systems have relied mainly on sonar systems that employ either a Mills cross array topology, as is the case for most multibeam echo sounders, or a parallel sidescan stave topology, as is the case for phase-measuring bathymetric sonars. We are currently exploring a novel array topology which utilizes a cylindrical array. A cylindrical array bathymetric sonar (CABS), as currently envisioned for this project, projects an annulus on the seafloor and receives from discrete azimuthal beams within that annulus (Figure 3-1). One of the anticipated benefits of this approach includes improved signal-to-noise (SNR) for seafloor detections through reduced reverberation of the seafloor at other angles, as is commonly observed with conventional MBES. A second potential benefit is an increased sounding density: given the geometry of the annulus, this system offers multiple, independent 'looks' at the seabed given the overlap between pings. This multi-look bathymetric system is anticipated to offer a more statistically robust measure of seafloor bathymetry.

Data collected from a Simrad SU90 in the spring of 2016 continues to be the foundation of this work. The SU90 is cylindri-

cal array designed for fisheries applications, and although it lacks the resolution required for a state-of-the-art bathymetric sonar, it offers a valuable first look at conducting seafloor mapping with a CABS-type sensor topology. We continue to analyze these data, collected during a short experiment conducted by Kongsberg Maritime near Horton, Norway, with a focus on understanding whether the system has achieved an improved SNR through reduced seafloor reverberation. CABS systems are expected to rely primarily on phase detections because the annulus (i.e., the sonar footprint) is at a large oblique angle to the transducer.

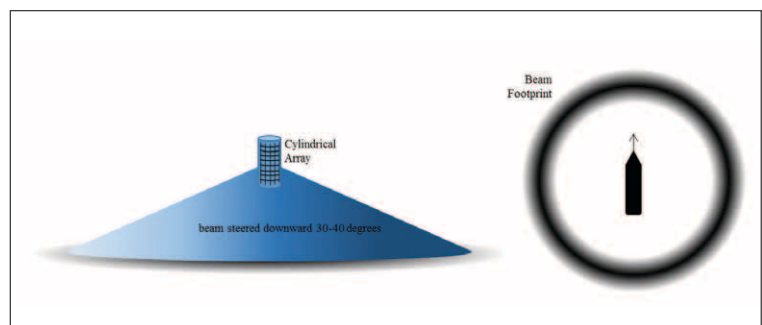

Figure 3-1. A conceptual diagram showing a cylindrical array and its field of view.

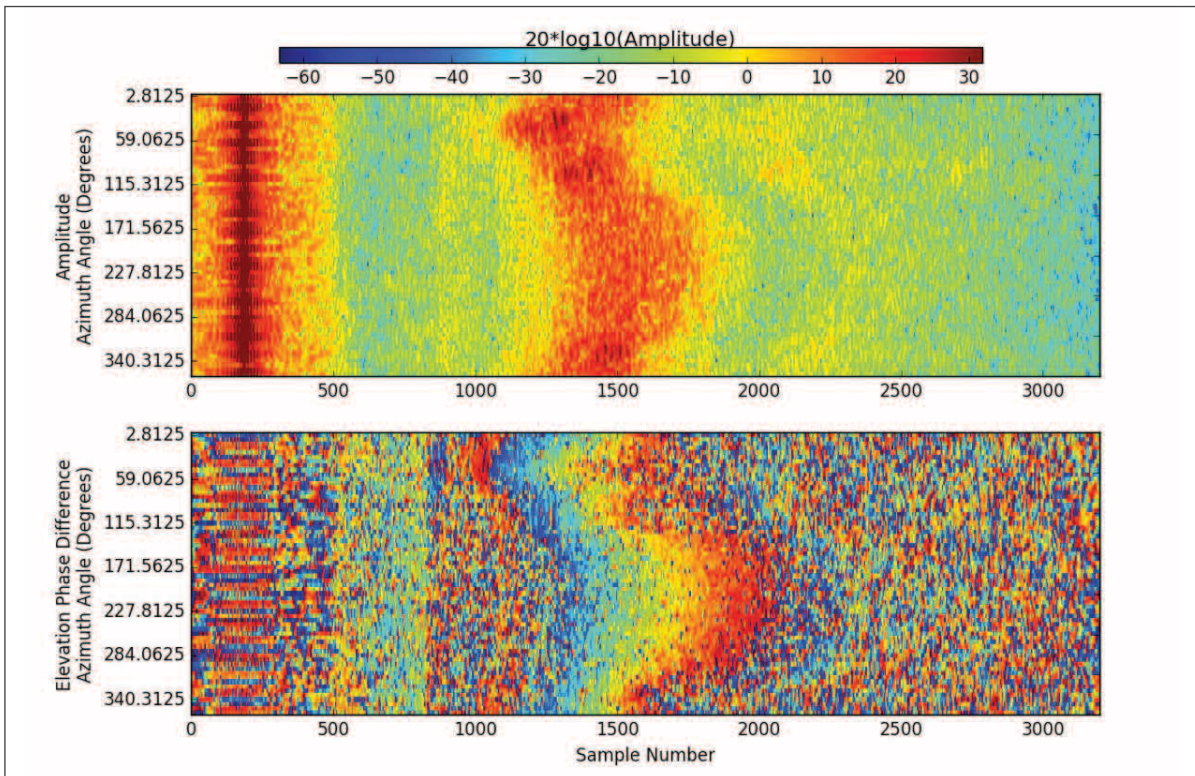

Figure 3-2. Raw amplitude (top) and phase (bottom) data collected with an SU90. The seafloor is apparent with high amplitude and quasi-linear phase between samples 1000-2000.

The focus of the SU90 data analysis is on understanding higher-than-anticipated noise in the seafloor phase detections (Figure 3-2). Phase ramp noise is typically associated with either low SNR due to weak signals or high ambient/self-noise, or with baseline decorrelation. These data are still being analyzed, causing a very healthy re-examination of our (Glen Rice's) beamformer and the entire processing pipeline.

Our analysis of the SU90- data has led us to the hypothesis that seafloor reverberation is driving the uncertainty. For example, a beam pointed at some specific azimuth angle has sidelobes pointed in all other directions, and scattered returns from these other directions likely act as incoherent noise that may substantially reduce the effective SNR of the scattered return within the main beam. It is worth noting that the idea of reverberation limits on phase ramps, and the associated uncertainty in soundings, would likely affect and possibly limit conventional MBES as well as the omnidirectional sonars. That is, the results of this

examination may help us refine our understanding of the uncertainty limits on all seafloor mapping systems that use phase-differencing approaches.

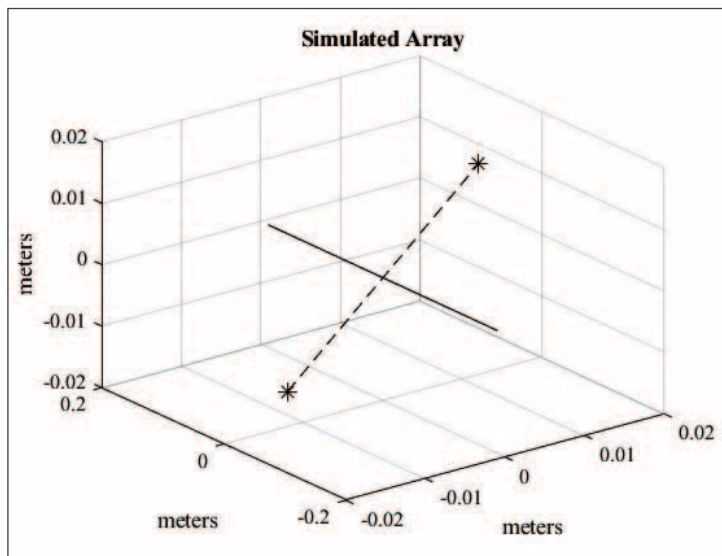

Figure 3-3. The simulated transmit line array (blue line) and received array (two black dots). Note that the horizontal axes differ by an order of magnitude.



We (Hamel) are currently exploring the idea of performing some controlled tests that specifically target his hypothesis. This exercise has begun with a computer-based simulation where we have complete control over all parameters (beam width, sidelobes, seabed, environment). The simulation synthesizes a transmit line array, and a receive array made of up of two ideal point-receivers that are used to generate a split-aperture and the associated phase difference (Figure 3-3). These arrays are placed a distance of 20 m above a synthetic seabed. Each point on the seabed is randomized in phase. The simulation begins by predicting the transmit beam imprint on the seabed (Figure 3-4). At any instant in time, the transmit pulse would interact with a slice (a segment of an annulus) extend in the along-track direction (vertically, in the image reference shown in Figure 3-4). This pulse would intersect the main beam—which is the region of interest, from which the phase-difference at the receive array needs to be calculated to localize a bottom detection—but would also intersect all of the sidelobes in the along-track direction. The hypothesis we are testing suggests that these sidelobe returns, which occur at different geometries that would be reflected in different phase differences, have a non-negligible impact on the phase ramp when taken in the aggregate.

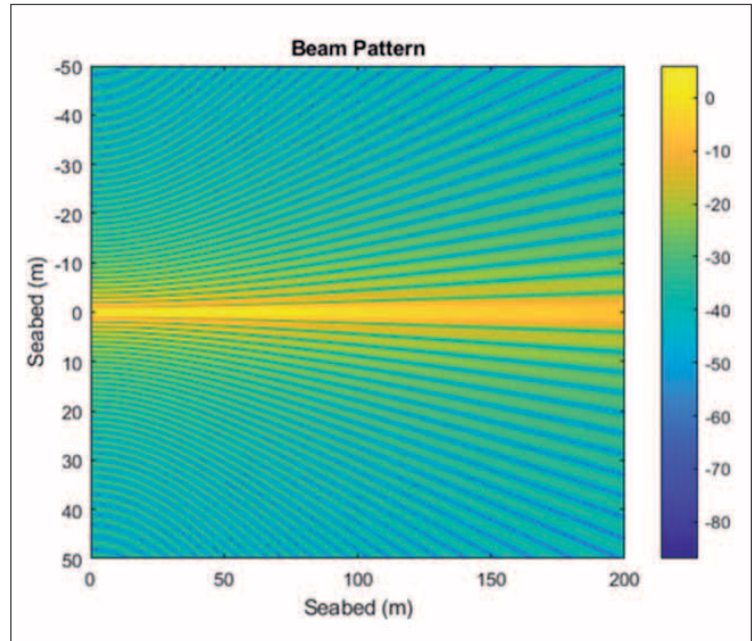

Figure 3-4. The transmit beam pattern imposed on the simulated seabed.

Assuming our hypothesis to be true, for a real-life system, this impact could be mitigated through the use of sidelobe suppression techniques like amplitude shading. For this simulation, though, it is possible to simply ignore (not include) some of the sidelobe contributions. Accordingly, the phase ramp noise was examined by first considering across-track direction sections of the seabed that were 0.5, 1, 2, 5, 10, 25,

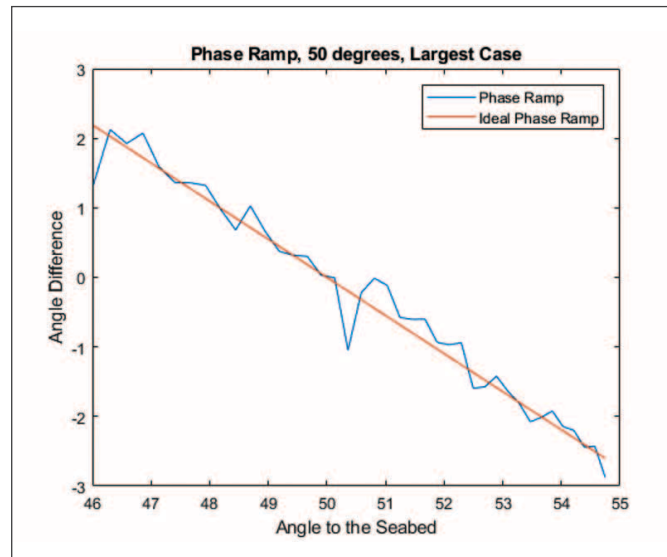
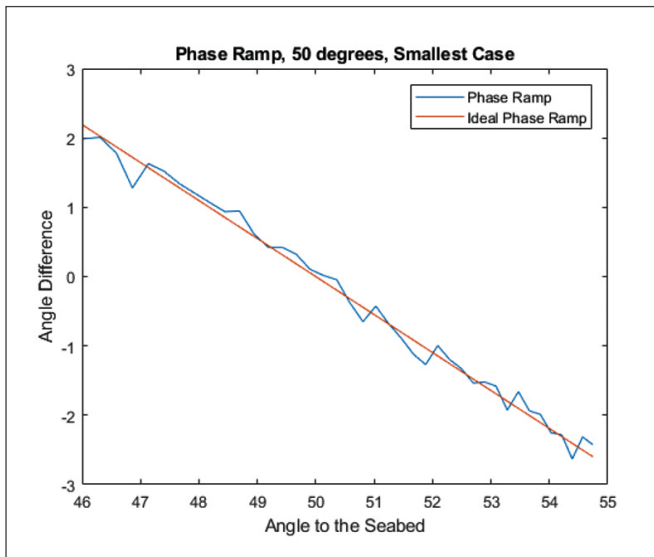

Figure 3-5. The phase-difference observed at the receive pair shown in Figure 3-3 for the case where only the main beam is considered in the seabed response (left), and the case where the full simulation including main beam and sidelobes is considered (right). The blue line is the observed (simulated) phase ramp, and the red line is the ideal analytical solution based on the geometry of the seabed and the receiver pair. Note that 50° corresponds to the angle to the (flat) seabed which is perpendicular to the receiver baseline.

50, and 100 m long. In the shortest case, only a segment of the main beam is included. In the longest case, the entire seabed shown in Figure 3-4 is included. For a single realization of the phase-randomized seabed, the phase ramps corresponding to the 0.5 m (shortest) and 100 m (longest) along-track portions of the seabed are shown in Figure 3-5. Qualitatively, it appears that the 100 m case, which includes the seabed returns associated with sidelobes, is noisier. To help quantify this, the simulation was run for varying amplitude shading functions, and the output was compared to an ideal, analytically derived phase ramp.

The overall results of the numerical simulation are shown in Figure 3-6. In this simulation, the baseline decorrelation line shows the conventional estimate for the lowest phase-ramp noise achievable with a typical Mills-Cross array topology. Baseline decorrelation accounts only for effects in the across-track direction—essentially a 2D view of the physics governing this scenario. For all window choices (e.g., uniform, triangle, etc.), when only a narrow along-track portion of the seabed is included, the numerical solutions converge to the baseline decorrelation estimate (see the left-hand side of Figure 3-6). The two windows with the lowest sidelobes—the triangle window (first sidelobes starting at approximately -27 dB and decreasing rapidly with arrival angle) and the Chebyshev window with constant sidelobes at -50 dB—show performance that is essentially at the limit of baseline decorrelation. Both the uniform window and the Chebyshev window with -25 dB sidelobes perform significantly worse than the baseline decorrelation limit—nearly an order of magnitude more noise. Interestingly, the uniform window out-performs the Chebyshev window with -25 dB sidelobes when the full along-track range of the seabed is included. This is thought to be because the Chebyshev sidelobe peaks are constant regardless of angle, whereas the uniform window sidelobes decrease dramatically with increased arrival angle.

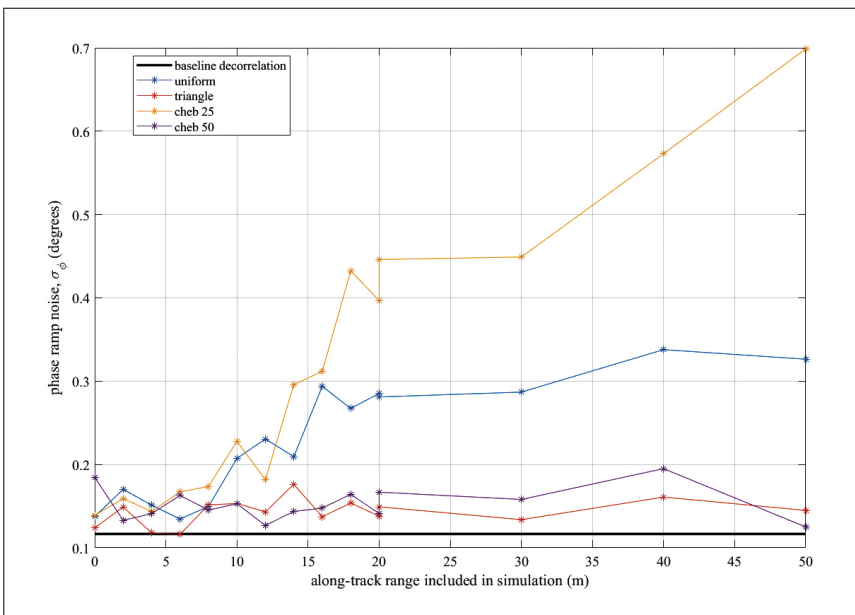

Figure 3-6. Phase ramp uncertainty as a function of along-track seabed length (a proxy for how much of the sidelobe returns were included) for different transmit array shading functions. The black line represents baseline decorrelation.

The results of these simulations suggest that a relatively simple transmit array shading—the triangle window—is likely the most effective window to use for seafloor mapping systems. It is relatively easy to construct, and simulations suggest that it approaches the phase-ramp noise limit due to baseline decorrelation. It is important to note that these effects have not previously been studied, at least in the open literature, and appear to represent an important and relatively simple step forward that could be taken by sonar manufacturers to decrease phase ramp noise and, consequently, increase achievable along-track sounding resolution and decrease sounding uncertainty.

We are currently exploring the idea of field-testing these ideas with the aid of three different transmit arrays: three 1 degree arrays, one with a uniform window, one with a Chebyshev window with 25 dB sidelobe suppression, and one with a triangle window. We have begun discussions with Material Systems, Inc. (now owned by Airmar) who have the technical capacity to construct these type of arrays, and hope to be moving forward with an acquisition of three prototypes in January 2020. These would then be used to conduct field trials with the goal of confirming the numerical simulations.

**TASK 4: Synthetic Aperture Sonar: Deriving Hydrographic-Quality Phase Difference Bathymetric Solutions with Parallel Synthetic Staves.** PIs: **Anthony Lyons and Tom Weber**

**Project: Evaluating Synthetic Aperture Sonar**

JHC Participants: Anthony Lyons and Tom Weber

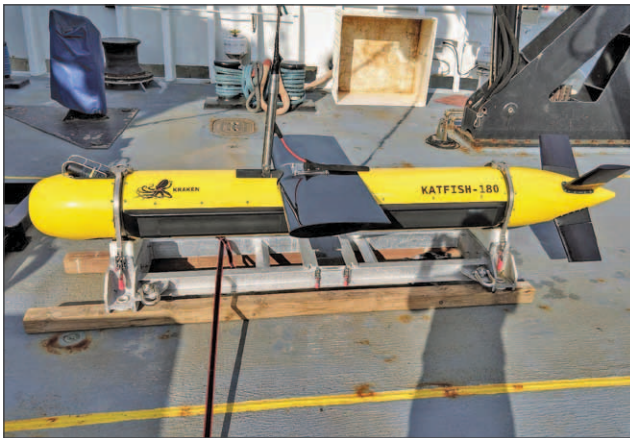

Figure 4-1. The KATFISH system on the deck of the *Okeanos Explorer*.

Synthetic aperture sonar (SAS), with multiple parallel synthetic staves, can provide both high-resolution imaging at far ranges and phase-difference bathymetric solutions. The requirements for very stable platforms (e.g., AUVs) and the high cost of these systems makes SAS an unlikely tool for hydrographic mapping. However, the high resolution of these systems may provide some benefit for the detection and localization of small underwater hazards and targets of interest. We continue to evaluate the performance and utility of off-the-shelf AUV mounted and towed SAS systems.

From July 18 to July 24, 2019, ThayerMahan (owners of a Kraken system), and Kraken Robotics participated in an expedition on the NOAA Ship *Okeanos Explorer* to demonstrate the Kraken towed KATFISH with Synthetic Aperture Sonar (SAS) for possible integration into future NOAA operations. Test areas for the system mainly targeted underwater cultural heritage sites (UCH) on the continental shelf between Norfolk, VA and Davisville, RI. The UCH sites chosen for the SAS demonstration surveys were in water depths between approximately 40 m and 150 m. The KATFISH operational envelope is for depths less than 300 m and greater than 10 m (hypothetically, based on multipath and towfish stability). The KATFISH system (Figure 4-1) is comprised of an

actively controlled smart towfish housing an Aqua-Pix MINSAS SAS imaging (and bathymetry) system and a gap-filler sonar, a ‘smart’ winch launch and recovery system (the Tentacle Intelligent Winch), an operator console, and visualization software). The system collects 3D bathymetry (approximately 25 cm x 25 cm expected resolution; Figure 4-2) and high-resolution seabed imagery (approximately 3 cm x 3cm expected resolution, Figure 4-3).

One obvious advantage of the Kraken towed SAS system is the very high resolution over a 320 m swath (160 m on each side). The approximately 300 m swath was obtained at the recommended operating height of 20 m. Larger swaths may be possible, but incur other possible tradeoffs such as signal to noise degradation at far range, increased ‘gap’ not imaged by the SAS, etc. Another large advantage of the KATFISH is that the SAS can be run at faster speeds than an AUV mounted SAS system owing

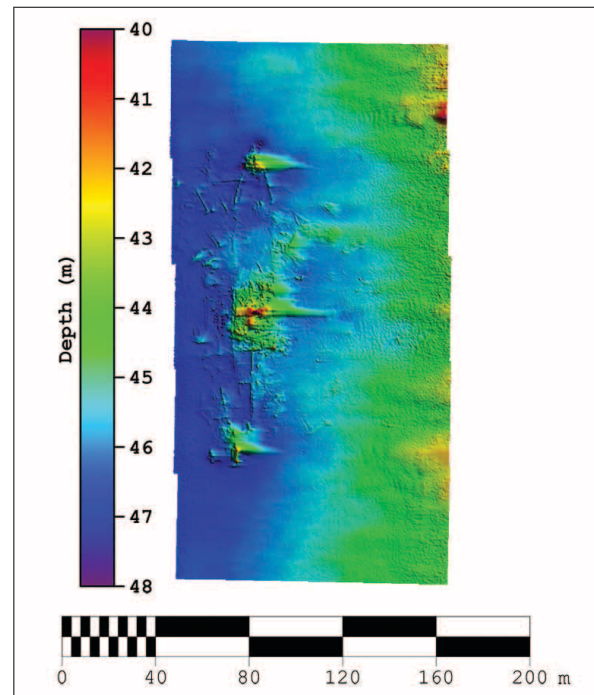

Figure 4-2. Bathymetric map of a shipwreck site off of Virginia using the KATFISH towed SAS system.



to its long receive array (180 cm). While AUV systems typically are run at 4 knots, the KATFISH was regularly run at 6 knots during the technology demonstration and images were produced with tow speeds as fast as 8 knots. Just as in conventional side-scan, a gap filler is required. As this is a low-angle system, oceanographic effects (refraction) sometimes caused problems at far ranges during the surveys. One last rather large advantage of the towed system is that images are seen in real time, so that survey adjustments can be done on the fly and the quality of the images can be checked in real time (unlike for an AUV-mounted SAS).

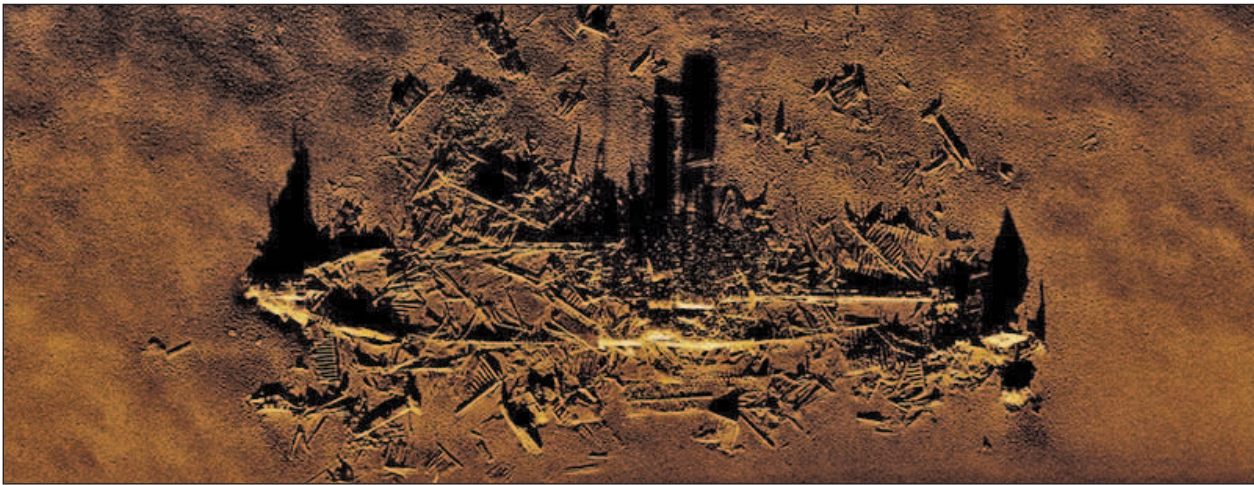

Figure 4-3. Synthetic aperture sonar image collected over a shipwreck site off of Virginia using the KATFISH towed SAS system.

## THEME: 1.A.2 Sensor Integration and Real-Time Qa/Qc

**TASK 7: Deterministic Error Analysis Tools:** *Further develop a suite of real-time and post-processing analysis tools to help operators see systematic integration problems in their configuration, e.g., wobble analysis tools including separating motion latency/scaling issues from surface and near-surface sound speed modulations, the use of water column information as a tool for identifying interference, noise sources, and bottom-detection issues. Improved low grazing angle bottom detection for more robust target detection, and tools to assure optimal quality of backscatter data, as well as tools to extract angular response curves that feed into our seafloor characterization developments. PI: **John Hughes Clarke***

**JHC Participants:** John Hughes Clarke, Brandon Maingot, and Brian Calder

**NOAA Collaborators:** Sam Greenaway and Glen Rice, NOAA-HSTP

**Other Collaborators:** Rebecca Martinolich, Dave Fabre, NAVOCEANO; Ken Fitzgerald, Glostens; Ian Church, UNB OMG

This task seeks improved means of assessing performance degradation of swath sonar systems by looking at correlations between the acquired data and the driving forces. The two main reasons for performance degradation are imperfect integration of the observed position and orientation (internal), and; environmental overprinting due to sea-state limitations (external).

### Integration Problems

With the ever improving accuracy of the component sensors in an integrated multibeam system, the resultant residual errors have come to be dominated

by the integration rather than the sensors themselves. Identifying the driving factors behind the residual errors (the periodic ones routinely referred to as “wobbles”), requires an understanding of the way they become manifest. In this reporting period, modeling tools have continued to be developed to better undertake wobble analysis.

### Rigorous Inter-Sensor Calibrator

As the OCS fleet increasingly switches to multi-sector multi-swath sonar to improve operational performance, there is a growing need to rapidly identify integration errors in these complex systems. In

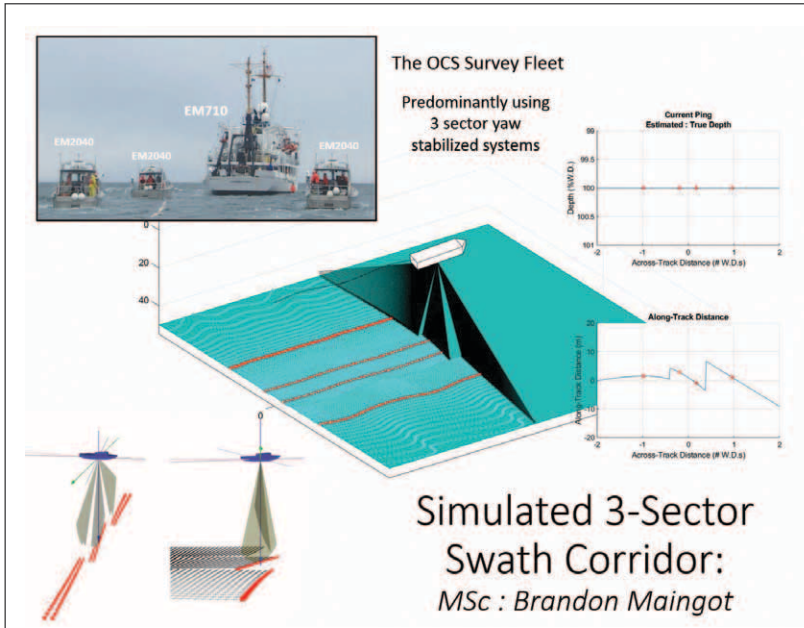

Figure 7-1. Simulator that recreates the geometry of a multi-sector system operating in open ocean motion dynamics while acquiring over a user-specified undulating seafloor.

August, Brandon Maingot successfully defended his master's thesis on the development of an automated approach that quantitatively assesses the mismatch between the estimated long wavelength seafloor relief and the observed data. To do this, he first developed a full simulator for a multi-sector sonar acquiring data under controlled dynamic conditions, which collects bottom tracking information over undulating seafloor topography (Figure 7-1). That acquired data is then deliberately re-integrated using erroneous parameters to create a "wobbled" seafloor (Figure 7-2). This then provides the input, equivalent to a real system, in which the errors are perfectly known and an approach may be developed and tested to see how close to the truth an inversion can achieve.

The challenge of any field analysis tool is to try to guess how the data should look in the absence of the integration problem. To do that an estimate of the seafloor "truth" needs to be established. Maingot's approach follows earlier methods in assuming that the underlying seafloor does not

have short wavelength roughness with a length scale corresponding to the projected motion. This is done by fitting a quadratic surface to a short section of the swath corridor. Using that surface "truth," the mismatch of each of the soundings to that quadratic estimate are used as the input into a least squares minimization approach. This is termed the Rigorous Inter-Sensor Calibrator (RISC).

Underlying the RISC is a unique georeferencing model that identifies and separates the effect of each of six common integration errors as inputs into the sounding calculation. In this way each sounding may be handled as a discrete observation and, using the several thousand observations in one local surface fit (during which the orientation is continually changing), a least squares approach can estimate

the six input integration errors. For each local surface, consisting of a local fit to the seafloor over a length scale corresponding to a few wave periods, the estimates are imperfect. But if the estimates are continually reassessed as the fitted corridor is progressively offset along the swath track, the asymptotic average of the local estimates converges reliably toward the real solution (Figure 7-3).

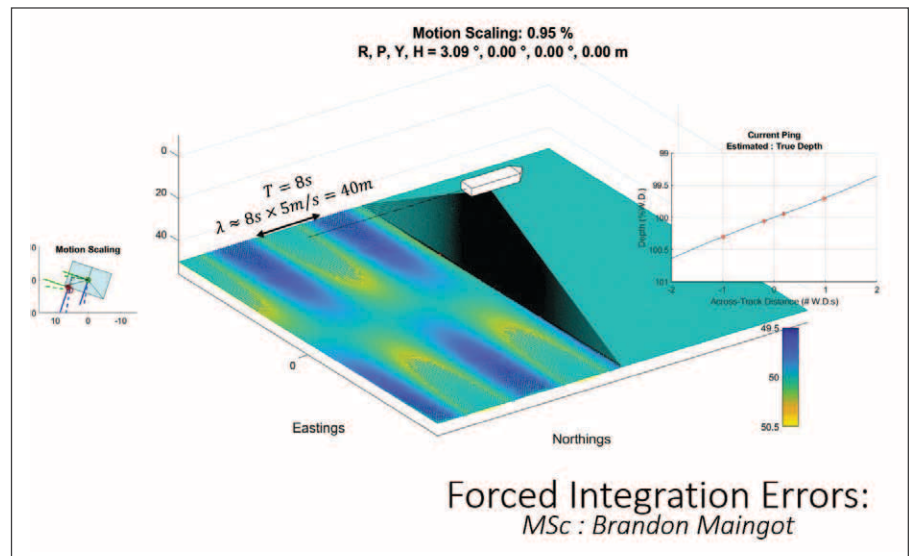

Figure 7-2. Generation of controlled wobble through the deliberate re-integration of motion using up to 6 simultaneous error types.

The need for this integration assessment has become particularly acute as OCS and their contractors are increasingly switching to ASVs to perform shallow surveys. ASVs can have particularly high motion dynamics (both in magnitude and rate) leading to the enhancement of what were previously considered minor “fine integration” imperfections. Maingot has now switched to an externally funded (Kongsberg) Ph.D. at the Center which is centered around taking this simulated solution and applying it to real data streams. The initial research focus has been twofold: to accept raw data streams (.all and .kml formats) as the input, and to improve the estimation and provide uncertainty estimates using Bayesian statistics approaches. Short period coherent undulations in bottom tracking remain one of the prime concerns in OCS hydrographic data quality control.

**Bubble Washdown**

Even with perfect integration of motion, if there are periodic external noise and sound blockage events due to bubbles close to the transducers generated by wave activity, this will overprint onto the data. Such extreme sea-state related issues are generally the reason why surveys are stopped. While there has been much speculation as to the origin and reason for these bubble washdown events, there has been little direct investigation of the phenomena.

To address this problem, Hughes Clarke has been taking advantage of the fact that, increasingly, deep water survey vessels are also equipped with shallow water multibeam sonar. While this second sonar cannot track the bottom in deep water, they can be set to “sonar mode” in order to image the volume scattering field within a few 10s to 100s of meters below the hull. This was originally developed by Hughes Clarke in 2016 to look at shallow oceanographic layering to view evidence of internal wave activity or other structural changes in the thermocline. What became apparent however, is that the method was also capable of seeing bubble clouds. As a result, Hughes Clarke has developed software to allow visualization (Figure 7-4) of the second-by-second evolution of the near-transducer scattering field and correlate it with the timing and location of the outgoing and resulting energy associated with the deep water multibeam.

Bubble washdown has always plagued ocean-going vessels. With the gradual revitalization of the NOAA fleet, the ability to monitor the second by second performance of the under hull environment will aid in the design and placement of transducers as well as provide a monitoring tool to help in operational survey decisions.

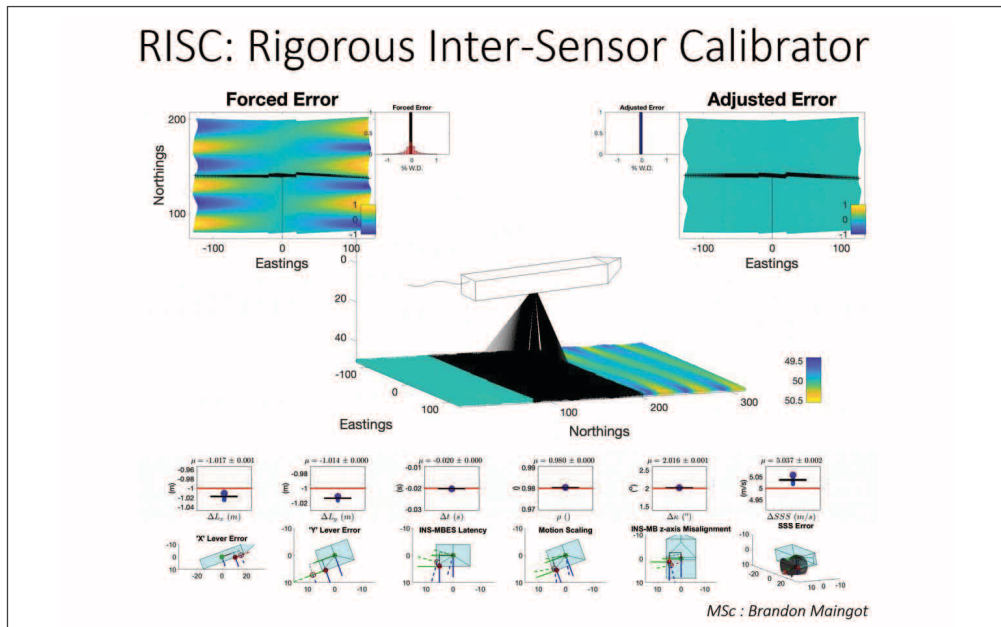

Figure 7-3. Input wobbled seafloor (top-left), the selection of the swath corridor (center), the resulting local and asymptotic estimation of the six integration errors (bottom) and finally the resulting de-wobbled surface (top right).



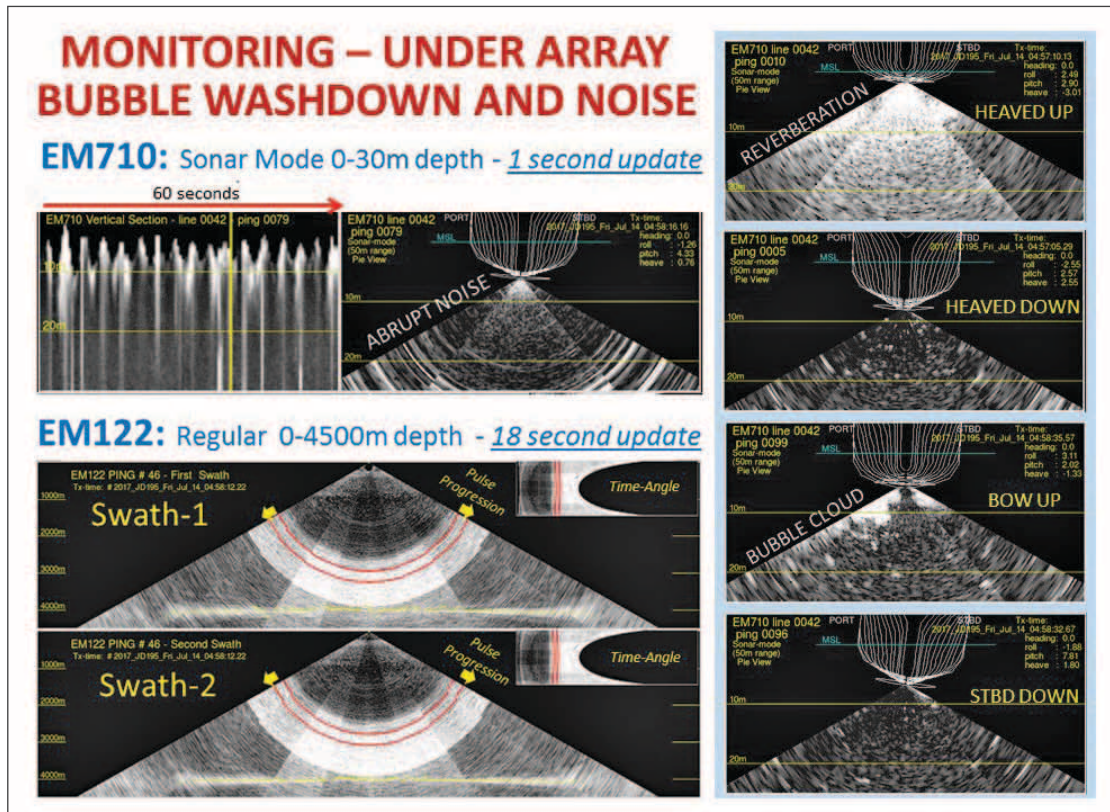

Figure 7-4. Simultaneous monitoring of near-array scattering and its effect on multi-second, deep-water multibeam performance. Top-left shows 60 seconds curtain of volume scattering within 30 m of the surface, together with instantaneous across track view of the scattering field. Bottom-left shows an 18-second ping cycle of an EM122, highlighting the 1-second period during which the near array image above was collected. Right shows stills of an animation showing the second-by-second evolution of the scattering field immediately under the hull during a single EM122 ping cycle.

**TASK 8: Data Performance Monitoring:** Investigate algorithms that could be used for real-time, or near real-time, monitoring of multibeam data, including methods for establishing a baseline performance metric for a class of systems, comparison methods for individual systems, and means to allow tracking of performance over time. We will also consider common methods pioneered through our NSF-funded Multibeam Advisory Committee for adaptation into shallow water environments, and visual feedback mechanisms that allow for clarity of real-time alerts for the operator. PI: **Brian Calder**

**JHC Participants:** Giuseppe Masetti, Paul Johnson, Kevin Jerram, Michael Smith, and Larry Mayer

**Other Collaborators:** Andrew Armstrong (NOAA OCS), Tyanne Faulkes (NOAA PHB); Matthew Sharr, Shelley Deveraux, Barry Gallagher, and Chen Zhang (NOAA HSTB); John Kelley, and Jason Greenlaw (NOAA NOS).

An alternative approach to more sophisticated data processing techniques is to collect better qualified data earlier in the process: it is important to consider the “total cost of ownership” (TCO) for hydrographic data, which includes not only the physical cost of collecting the data, but also the processing costs subsequent to initial collection. A characteristic of hydrographic and ocean mapping data seems to be

that the cost to correct a problem increases the further from the point of collection it is detected. Consequently, tools to monitor data in real-time, or to provide better support for data collection and quality monitoring have the potential to significantly reduce the TCO, or at least provide better assurance that no potentially problematic issues exist in the data before the survey vessel leaves the vicinity.

## Sound Speed Manager (HydrOffice)

The execution of a modern survey using acoustic sensors necessitates an accurate environmental characterization of the water column. In particular, the selected sound speed profile is critical for ray tracing, while knowing the temperature and salinity variability are crucial in the calculation of absorption coefficients, which are important for gain setting in acoustic sensors and compensation of backscatter records.

Since 2016, Giuseppe Masetti and Brian Calder have been collaborating with NOAA Hydrographic Systems and Technology Branch (HSTB) on the development of an open-source application to manage sound speed profiles, their processing, and storage. The Sound Speed Manager (SSM) project (Figure 8-1) combines HSTB's Velocipy and the Center's SSP Manager (both of which have significantly longer development histories, going back to the 1980s in the case of Velocipy). This combination provides the best of both applications, removes code duplication, and enables a long-term support plan for the application.

In the current reporting period, SSM development has been incremental, improving the back-end database structure and adding new data input and output formats. During the 2018 field season, SSM was in use in the NOAA and UNOLS fleets (as well as by a number of professional and other agencies from all

around the world). Based on field feedback (NOAA-specific comments were collected by Lt. Matthew Sharr and Lt. Shelley Deveraux), several improvements have been applied to the user interface, data formats (i.e., support for CSV, AML, Ocean Science, and Valeport), processing, and analysis. After being tested, these changes were released to the NOAA field units for the 2019 field season. In preparation for the adoption by the NOAA fleet of Kongsberg SIS version 5, K-Controller, and kmall format (recently released by Kongsberg for their newest MBES systems), experimental support for these technologies has been added to SSM (Figure 8-2). Michael Smith has also added support for several NOAA regional operational forecast models (e.g., Gulf of Maine Operational Forecast System). This addition greatly increases the spatial resolution and temporal granularity when surveying in areas covered by those models.

The tool, which is freely available, has also been distributed as a stand-alone application through the U.S. University-National Oceanographic Laboratory System (UNOLS) fleet by Paul Johnson and Kevin Jeram, acting on behalf of the National Science Foundation (NSF) funded Multibeam Advisory Committee (MAC). Based on feedback received during the year, the code also appears to have been successfully

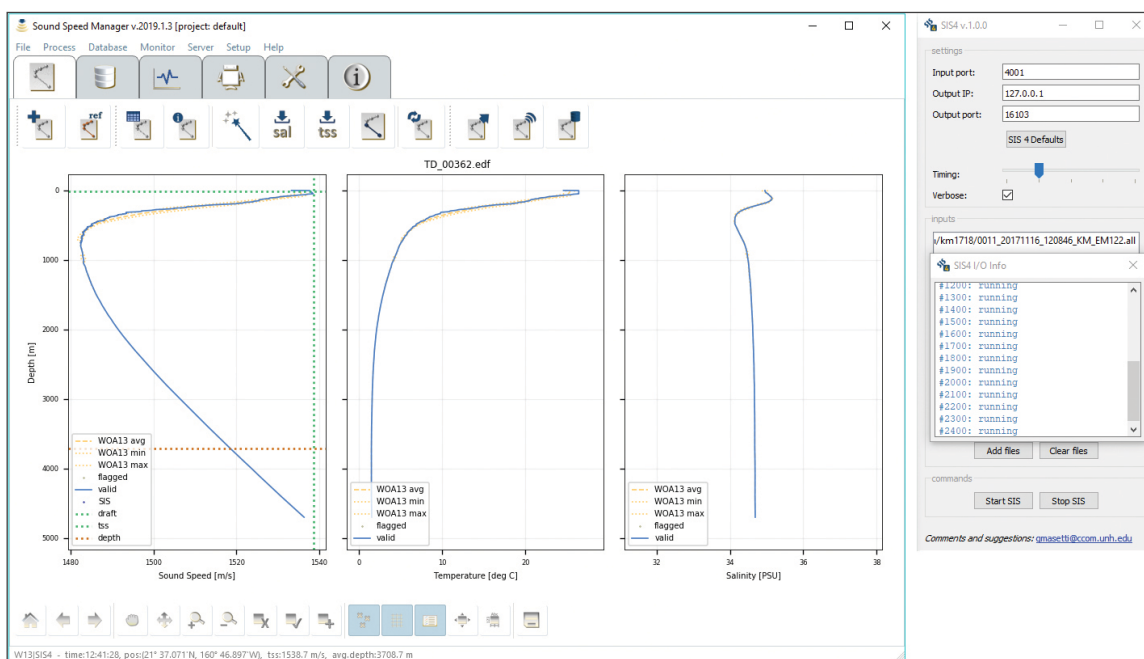

Figure 8-1. On the left, the Sound Speed Manager front-end GUI, showing an expendable bathythermograph (XBT) profile being reprocessed with salinity from an oceanographic climatology (i.e., the NOAA World Ocean Atlas 2013). On the right, a Kongsberg SIS emulator created to facilitate SSM development and testing.

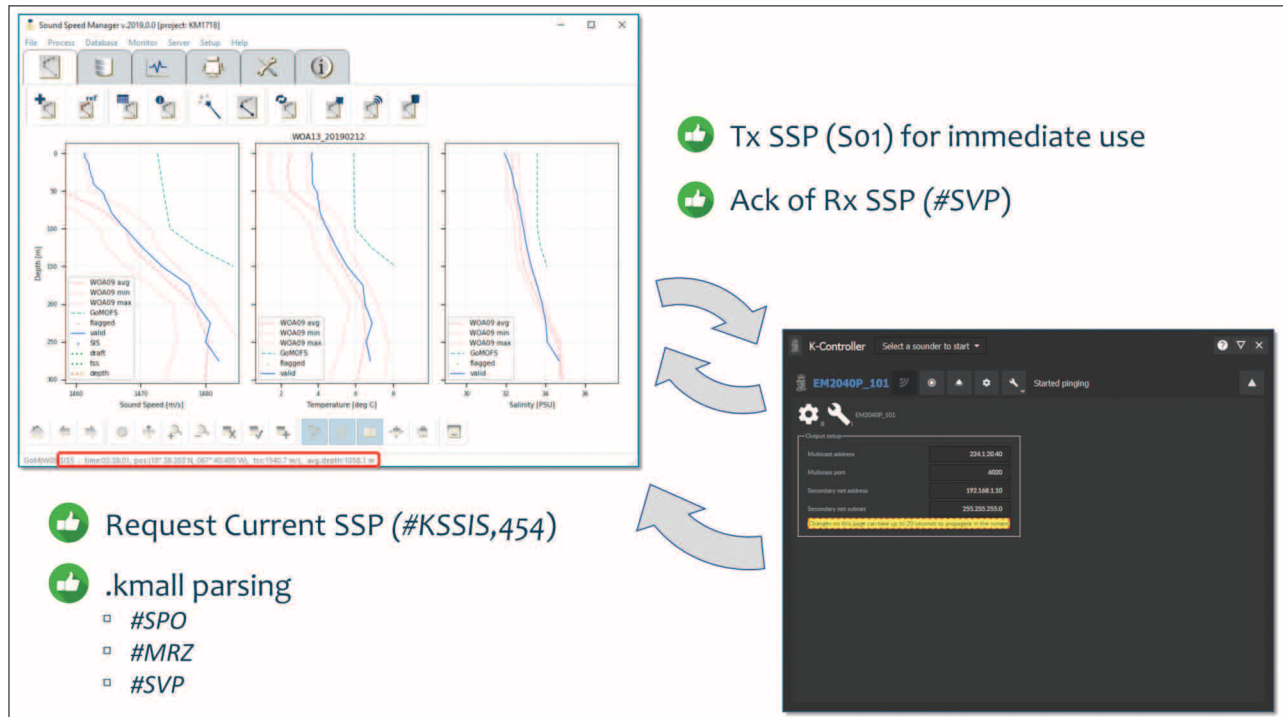

Figure 8-2. Summary of the current interactions for the experimental support of the Kongsberg K-Controller. SSM is able to transmit the enhanced sound speed profile data to K-Controller for immediate use, check its reception, retrieve the current profile, and parse the information-rich .ksmall datagrams broadcast through UDP protocol packets.

adopted by dozens of hydrographers all around the world. The success of SSM has contributed to increasing popularity for the HydrOffice framework (Figure 8-3) which is used globally. SSM is also available through the official NOAA Python distribution (a.k.a. Pydro), and since Pydro is freely available for public distribution, its auto-updating mechanism is an attractive way for users to easily get the latest updates to SSM.

\* *Sound Speed Manager is partially funded by the NSF MAC.*

**SmartMap (HydrOffice)**

Capturing sound speed profiles (SSPs) typically involves stopping the survey for a period of time, which is inefficient. But not taking a sufficient number of SSPs will lead to data quality problems. Therefore, knowing when, where, and how often to take them is very important. In previous reporting periods, the Center has pursued the idea of providing a “weather” prediction for the survey area, indicating areas where there is particularly high or low variability in the sound

speed expected, allowing the surveyor to assess how often to take profiles, where to take them, or even (in extreme circumstances) conclude that there is no rate at which SSPs can practically be taken that will capture the variability of an area (with the implication that surveying at a different time is the more appropriate solution).

Since 2017, Giuseppe Masetti, John Kelley, and Paul Johnson have been developing the current generation of this idea in the Sea Mapper’s Acoustic Ray Tracing Monitor and Planning (SmartMap) project. The prototype system couples a ray-tracing model with ocean atlas climatological and real-time fore-

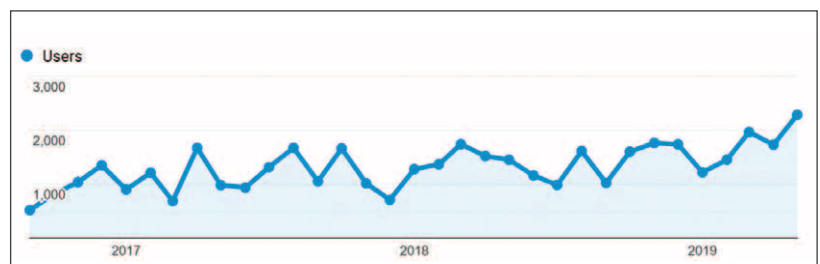

Figure 8-3. Accesses of HydrOffice online resources. The number of unique users has been steadily increasing since the initial launch in September 2016.



casting information to predict the uncertainty in hydrographically significant variables (such as the depth) that might be engendered during the survey. Since the maximum uncertainty typically occurs in the outer-most regions of a swath mapping system, the system predicts the uncertainty at 65 degrees off nadir, and then summarizes the results in a web-based front-end, supported by modern open-source web-map technologies. This simple visualization provides for rapid assessment of the effects of sound speed in any given area.

Since July 2017, the predictions for the Global Real-time Operational Forecast System (RTOFS) have been stored to provide a historical database with many potential applications, e.g., to identify sound speed-related issues in past surveys, that can be accessed through the GeoServer-based Web Map Service as well as on the Web GIS portal (<https://www.hydrooffice.org/smartmap/>).

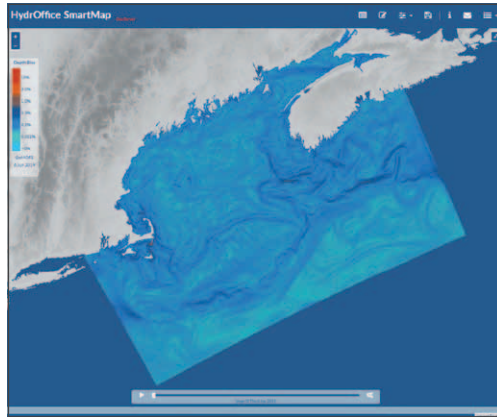

Figure 8-4. The experimental GoMOFS predictions are calculated daily using up to 72-h forecast model data made available on the NOAA servers.

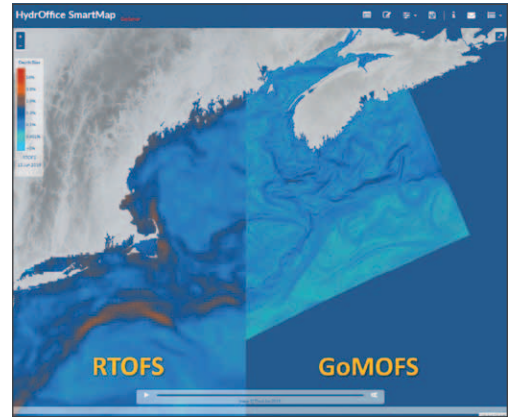

Figure 8-5. Comparison of the spatial resolution between the GoMOFS predictions (on the right) and the Global RTOFS one (on the left).

During the current year, experimental prediction products based on the Gulf of Maine Operational Forecast System (GoMOFS) data were added (Figure 8-4). Such products provide better spatio-temporal coverage for the Gulf of Maine (Figure 8-5), and the evaluation of their potential applications to shallow-water surveys has recently started.

\* *SmartMap is partially funded by the NSF MAC.*

**ForeCast**

Increasingly reliable ocean nowcast and forecast model predictions of key environmental variables—from local to global scales—are publicly available, and have many potential uses for survey planning and operations, but are often not used by ocean mappers. To address this situation, the ForeCast project evaluates some possible ocean mapping applications for commonly available oceanographic predictions by focusing on one of the available regional models: NOAA’s Gulf of Maine Operational Forecast System.

To commence this project, Giuseppe Masetti, Michael Smith, and Larry Mayer, in collaboration with NOAA personnel John Kelley and Andrew Armstrong, conducted a study to explore two main use cases. Using data collected by the 2019 UNH Hydrographic Field Course in the Gulf of Maine (Figures 8-6 and 8-7), an assessment was made of the depth differences that would be engendered-

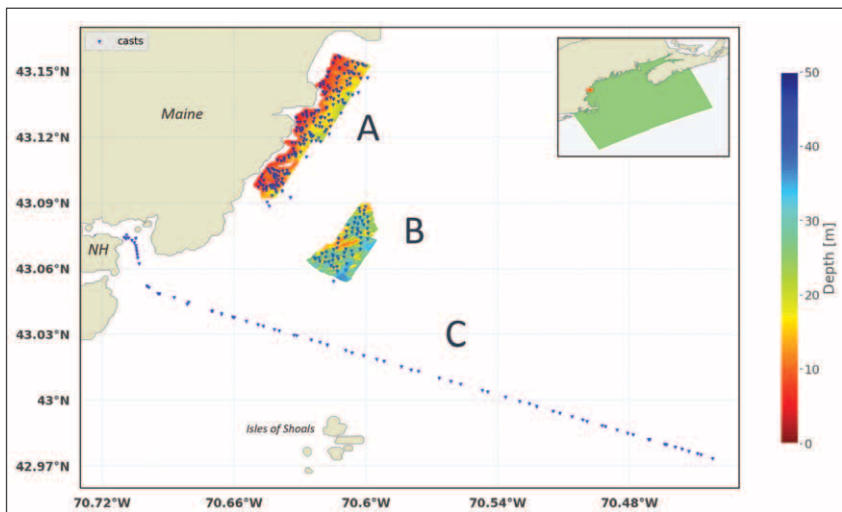

Figure 8-6. Bathymetric coverage completed by the UNH Hydrographic Field Course 2019. The collected casts (in blue) were grouped into three subsets: the “A” and “B” subsets corresponds to the two distinct surveyed areas, the “C” subset was collected during an offshore-sailing transect. The inset shows the locations of the survey area (red-framed yellow rectangle) and the GoMOFS domain (green tilted rectangle) in the Gulf of Maine.

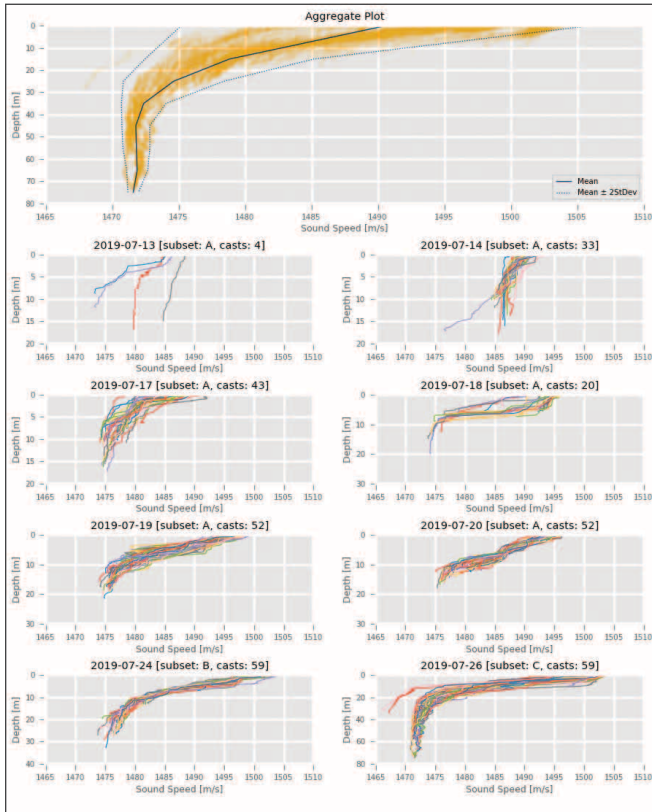

Figure 8-7. The upper pane shows the aggregate plot based on all the available casts (with the resulting average profile in blue). The other panes show the casts by subset and day of acquisition.

ered through use of predicted oceanographic variability in the water column to enhance and extend (or even substitute) the data collected on-site by sound speed profilers during survey data acquisition was examined (Figures 8-8, 8-9, and 8-10). Then, the uncertainty estimation of oceanographic variability was investigated

as a meaningful input to estimate the optimal time between sound speed casts.

This study triggered the design of new algorithms for each use case and their implementation as an extension of publicly-available ocean mapping tools (Sound Speed Manager and SmartMap). An analysis of ray-tracing uncertainty was used to evaluate a given sound speed profile sampling interval ranging from under-sampling to over-sampling the spatio-temporal variability of the water column. Building on the CastTime algorithm (Wilson et al., 2013), which focused on retrospective analysis of sound speed profiles, this work proposes a new method, called ForeCast, that adds the predicted spatio-temporal variability provided by an oceanographic forecast modeling system (i.e., the GoMOFS).

The main processing steps of the algorithm are (Figure 8-11):

- Application of a constant-gradient ray tracing algorithm for each newly acquired sound speed profile.
- Using uncertainty analysis, comparison of each newly collected cast with the latest acquired profiles.
- Retrieval of the local GoMOFS-derived spatio-temporal depth bias from the SmartMap WCS.
- Estimation of a new sampling interval based on previous intervals, the GoMOFS-derived spatio-temporal depth bias, and a specified maximum allowable tolerance.

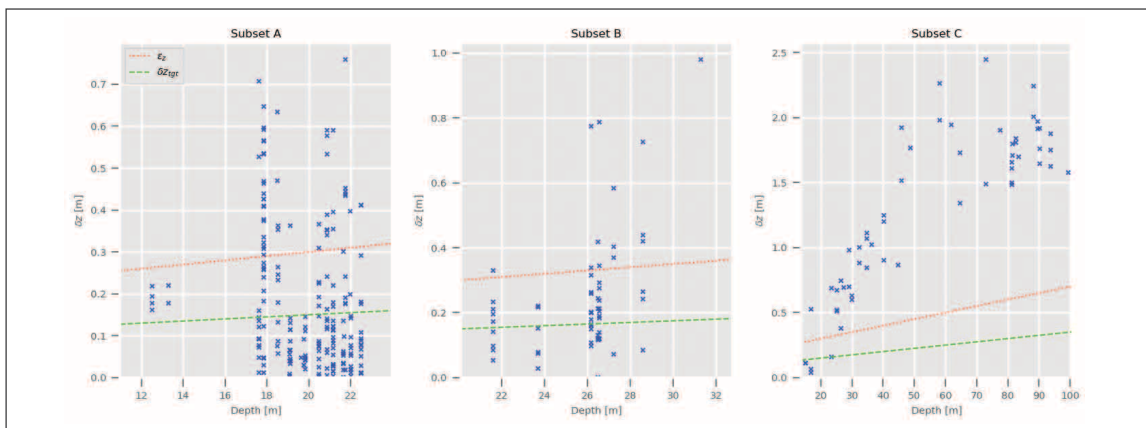

Figure 8-8. Comparison between collected sound speed profiles and predicted conditions. Each collected sound speed profile is compared against a synthetic profile retrieved from the GoMOFS predictions. The resulting depth bias ( $\delta z$ ) is shown with a blue cross, while the refraction error tolerance ( $\delta z_r$ ) and the target depth bias ( $\delta z_{tgt}$ ) are represented by a red dotted line and a green dashed line, respectively.

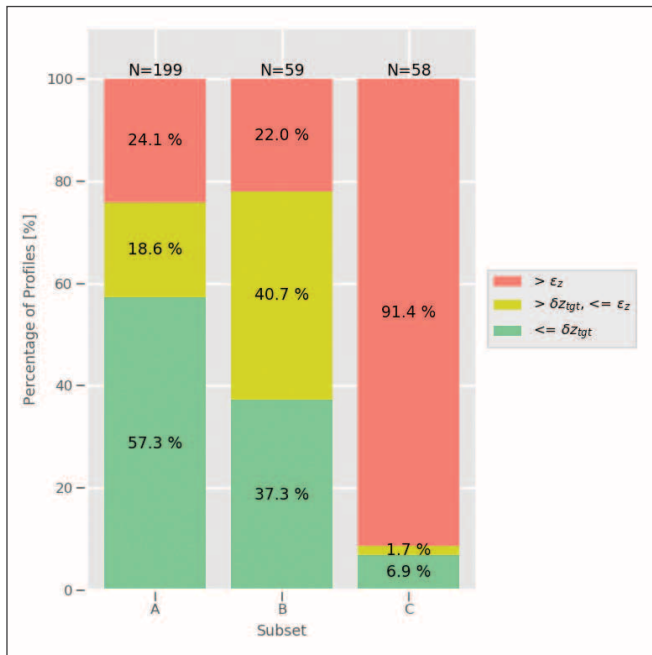

Figure 8-9. Percentages of GoMOPS-derived profiles per subset that have  $\delta z$  exceeding  $\delta z_{tgt}$  (in red), within  $\delta z$  and greater than  $\delta z_{tgt}$  (in yellow), and meeting the  $\delta z_{tgt}$  requirement (in green).

The study has provided evidence that the adoption of these techniques has the potential to improve efficiency in survey operations as well as the quality of the resulting ocean mapping products. Figure 8-12 shows the evolution of  $\delta z$  in different scenarios, using the

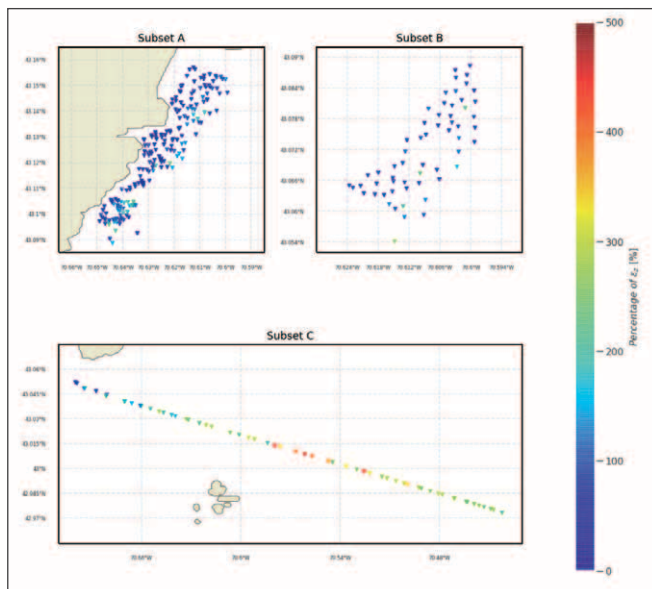

Figure 8-10. Georeferenced  $\delta z$  derived from comparing observations and GoMOPS-derived synthetic profiles. The values are represented as percentage of  $\delta z_z$ .

analysis of ray-tracing uncertainty to evaluate the utility of the current profile at different times. The worst-case scenario, Figure 8-12(a), clearly shows the need to perform additional casts after the collection of the first profile. The optimal solution, Figure 8-12(b), provides a baseline to evaluate the performance of the reactive-only (Figure 8-12(c)) and the full (Figure 8-12(d)) ForeCast algorithm. The full algorithm estimates cast times whose  $\delta z$  values are generally lower than the ones provided by the reactive-only algorithm. Furthermore, a surveyor following the full algorithm would have exceeded the threshold for  $\delta z$  in only one case (Figure 8-12(d)), while it happens a few times under other conditions. The proposed method therefore seems to alleviate the subjectivity in determining the casting interval and improves the overall sounding accuracy. However, more extensive test datasets need to be collected to confirm these results, and new data acquisition are planned for the Center’s Hydrographic Field Course in 2020.

The main findings of this study have been submitted as a journal article (with title “Applications of the Gulf of Maine Operational Forecast System to Enhance Spatio-Temporal Oceanographic Awareness for Ocean Mapping”) that has been accepted for publication on *Frontiers in Marine Science*. Furthermore, an overview of the developed tools will be presented at the 100th Meeting of the American Meteorological Society (Boston, 12–16 January 2020).

**Multibeam Advisory Committee Tools**

The Multibeam Advisory Committee (MAC), sponsored by NSF, is an on-going project dedicated to providing fleet-wide expertise in systems acceptance, calibration, and performance monitoring of the UNOLS fleet’s multibeam mapping systems. Since 2011, the MAC has performed systems acceptance tests, configuration checks, software maintenance, and self-noise testing for the U.S. academic fleet. In the current reporting period, NSF renewed funding for the MAC for the next five years. While the MAC has been developing tools for deep-water systems typically hull-mounted on UNOLS vessels, the same test requirements and techniques apply equally well to shallow water systems, with some adaptations. These tools have been applied to Center and NOAA multibeam activities, including quality



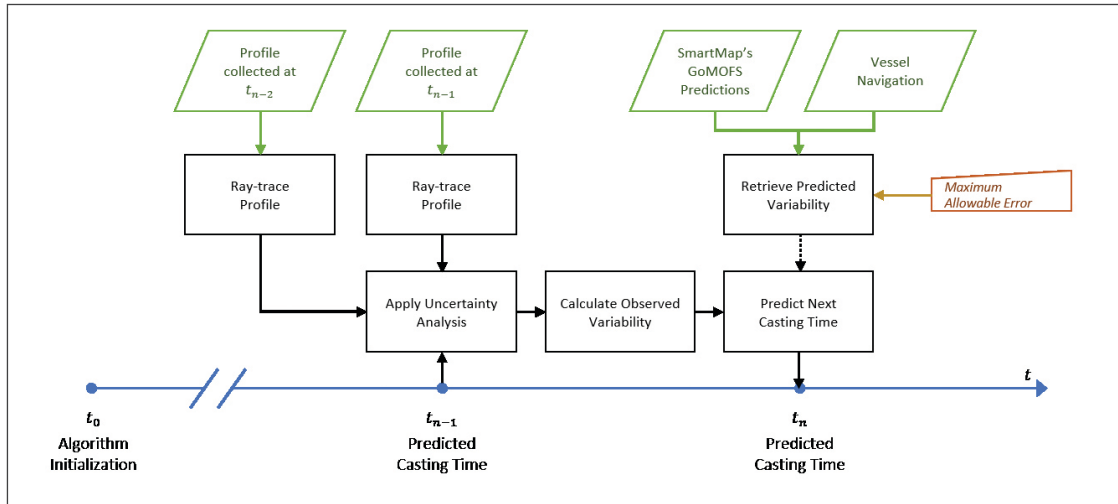

Figure 8-11. The ForeCast algorithm. The flowchart shows, in black, the main steps of the with a dashed connector when optional (i.e., the predictive component based on SmartMap’s GoMOFS maps). The inputs are represented in green, the user parameter in orange, and the timeline in blue.

assurance testing in May for the EM302 on board NOAA Ship *Okeanos Explorer* and the EM2040 installed on the Center’s ASV BEN.

Continuing from previous reporting periods, a joint effort is currently underway between NOAA and MAC personnel to develop graphical user interfaces (GUIs) for a selection of needed software tools, with the aim of empowering multibeam operators to more routinely and directly monitor indicators of system performance. Compared to existing commercial software tools used for multibeam processing (which may not be freely available for all operators), the GUIs under development provide more control over plotting and archiving of the test data for future comparisons of each system to itself and, importantly, to other comparable systems installed aboard other vessels throughout their service lives. Standalone GUI-based applications have been created in Python for tracking swath coverage (Figure 8-13), assessing swath accuracy

(Figure 8-14), and reducing Kongsberg file sizes to improve data transfer speeds (especially important when providing remote support to vessels). The file reduction tool recently found other unexpected uses, as it was modified to remove erroneous ping datagrams caused by an intermittent hardware failure (now resolved) from a backscatter calibration

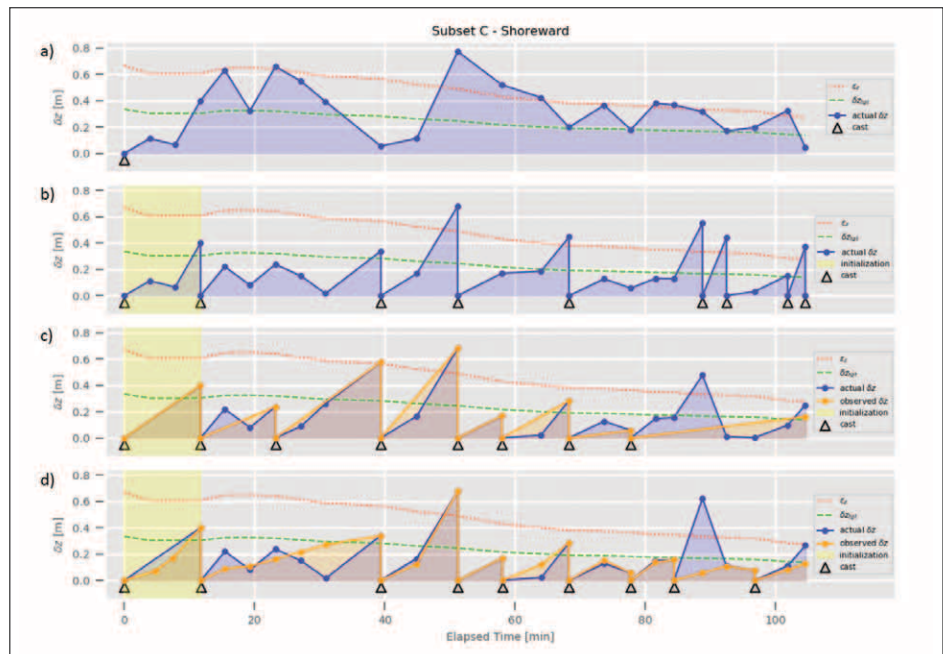

Figure 8-12. Prediction quality metrics for the ForeCast algorithm. Worst-case scenario (pane ‘a’), optimal solution (pane ‘b’), solutions from the reactive-only (pane ‘c’) and the full (pane ‘d’) ForeCast algorithm for profiles from Subset C collected in the shoreward direction.

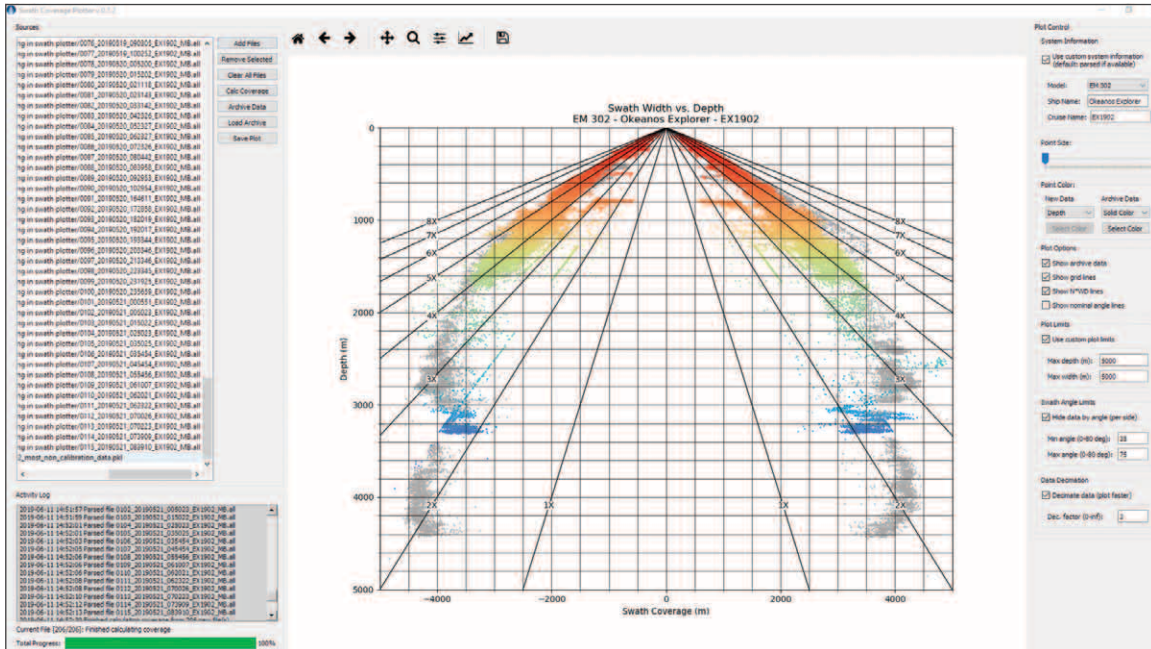

Figure 8-13. Swath coverage plotter GUI under development in a joint MAC-NOAA project, showing recent (EX1902, colored by depth) and archive (EX1802, gray) soundings for comparison of coverage achieved by the NOAA Ship *Okeanos Explorer*. The user has improved control over plotting and archiving data for comparison of a system to itself and others throughout its service life. Development is ongoing for this and other GUIs to simplify routine performance monitoring for multibeam operators throughout the UNOLS, NOAA, and academic fleets.

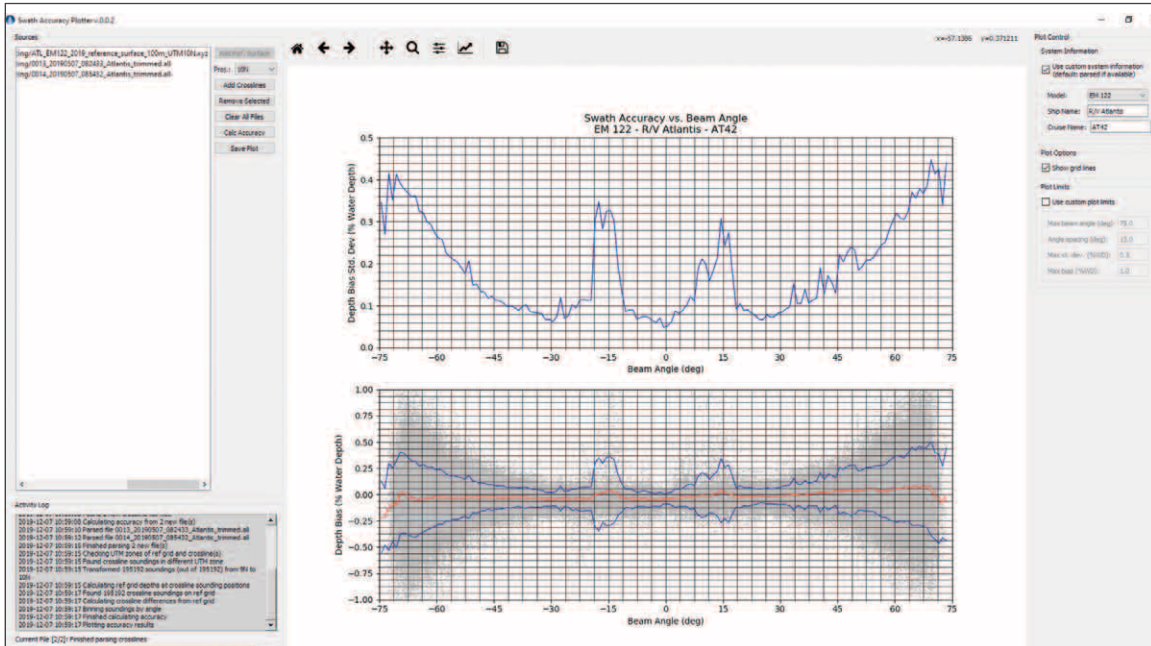

Figure 8-14. Swath accuracy analysis GUI under development in a joint MAC-NOAA project, showing mean biases (red) and standard deviations (blue) of deep-water MBES soundings relative to a bathymetric reference surface. Test data are binned in 1° increments across the swath and may be plotted in meters or as a percentage of water depth. The GUI provides additional plotting control and will support archive of test data to track system behavior over time, compare performance to other installations, and examine the effects of varying operational settings (e.g., runtime parameters, vessel noise, and sea state).



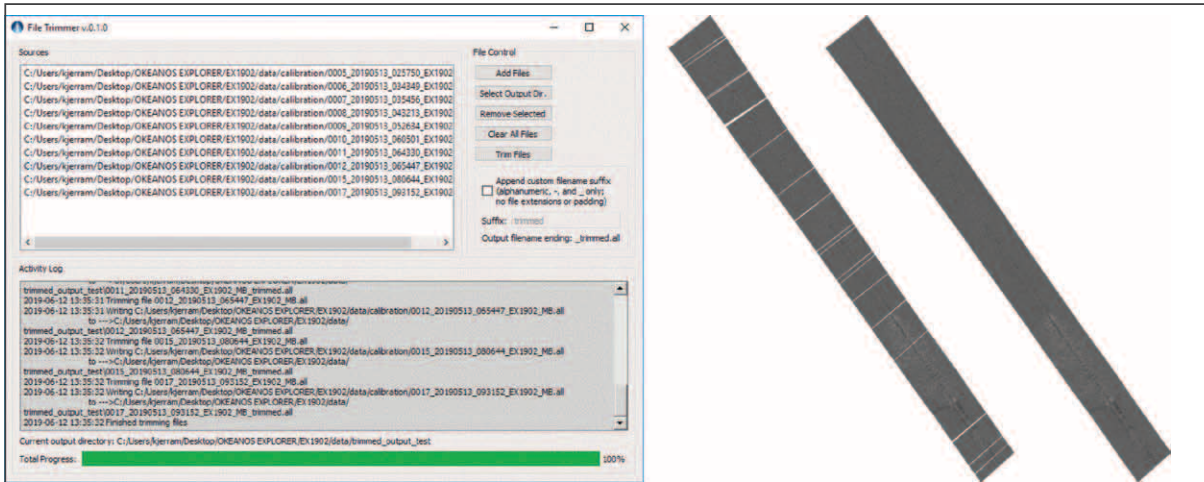

Figure 8-15. Example of the file trimmer GUI and its results. Left: File trimmer GUI for reducing Kongsberg .all file sizes by removing datagrams that are unnecessary for post-processing. This tool significantly increases the speed of data transfer from ship to shore for remote support. Right: During a backscatter calibration survey aboard the NOAA Ship *Okeanos Explorer* in May, the file trimmer was modified to remove all ping datagrams associated with abnormal backscatter values caused by a temporary hardware failure. Backscatter mosaics are shown for raw and trimmed versions of the same survey line; white stripes on the raw mosaic stem from anomalous data that could skew the calibration results if left in the file.

dataset collected aboard the NOAA Ship *Okeanos Explorer* in May (Figure 8-15). Related Python GUI projects are underway to analyze Built-In Self-Test data for multibeam hardware health, assess background noise levels, and adapt an existing MATLAB routine for tracking and querying data acquisition settings ('installation' and 'runtime' parameters) across large sets of survey files.

Routine geometric calibrations ("patch tests") are critical for improving and maintaining data quality. As ship schedules are set far in advance and rarely prioritize these calibrations, operators across the U.S. academic and NOAA fleets are often faced with the challenge of identifying suitable calibration sites that are within reasonable distances of planned science operations and transits. Johnson recently developed a web GIS application (<https://ccom.unh.edu/gis/tools>) to streamline this process and present users with seafloor regions meeting depth and slope criteria that support pitch, roll, and

heading calibration as well as accuracy assessments (Figure 8-16). These regions are colored according to the test type and appropriate multibeam echosounder frequency (i.e., intended depth capability).

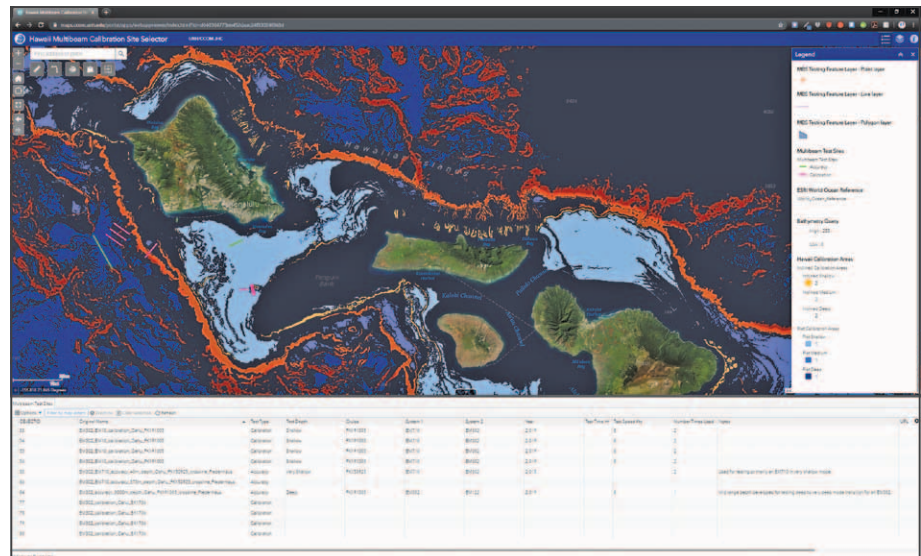

Figure 8-16. User interface for a web-based GIS tool (<https://ccom.unh.edu/gis/tools>) to aid in the selection of calibration and accuracy assessment sites. Regions with slopes of 15-30° are intended for pitch and heading calibrations (red), and regions with slopes less than 2° are intended for roll calibration and accuracy assessment (blue). Gradations of red and blue regions correspond to intended echosounder depth capability for each type of site. For instance, 'Shallow,' 'Medium,' and 'Deep' correspond to echosounders with nominal frequencies of 40-100, 30, and 12 kHz; these are presented as lighter, medium, and darker colors, respectively. Historic calibration lines and accuracy test sites are also shown, offering users the opportunity to use 'proven' calibration features (magenta) and efficiently reuse reference surfaces by running crosslines (green) only.



Calibration and accuracy test sites used previously by the MAC and NOAA are also presented to the user, with additional information such as the original vessel, system, and timeframe for each line plan. Other fields for planning purposes, such as expected duration on site and links to associated data sources, will be populated as the site selection tool matures. A major benefit of the web interface is the support for additional data layers for planning, such as SmartMap, surface currents, and vessel traffic (Figure 8-17).

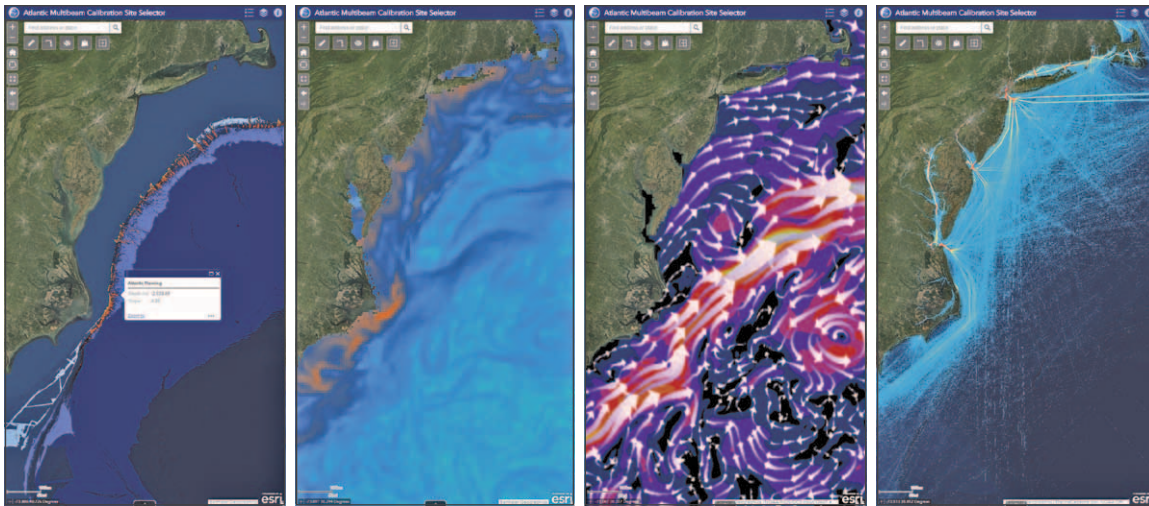

Figure 8-17. The web-based site selection tool presents additional oceanographic and logistical data layers, with the aim of identifying conditions suitable for high-quality data collection and improved performance monitoring. From left to right: test regions identified along the U.S. east coast; HydrOffice SmartMap sound speed environment data to assist in prioritizing low-variability areas for testing; NowCOAST surface currents aiding in line and speed planning to reduce vessel ‘crabbing’ during data collection; historic vessel traffic data (marinecadaster.gov) to augment guidance from navigation officers during line planning and reduce expected interference from other vessels.

**TASK 9: Automated Patch Test Tools:** Investigate the development of automated patch-test procedures including the estimation of the uncertainty inherent in the parameters estimated. **PI: Brian Calder**

**JHC Participants:** Brian Calder, Brandon Maingot, John Hughes Clarke

A rigorous means of estimating the patch test calibration parameters for a multibeam echosounder is essential for hydrographic practice. Standard methods exist for a static patch test, and a number of approaches to computing a patch test automatically have been reported in the literature. They typically, however, rely on carefully collected or selected data for success. This provides a static check at an instant in time on the performance of the system but is not ideal for real-time monitoring of the system’s health as it develops over time. For that, a dynamic patch test is required

In order to investigate how a dynamic patch test might be implemented, John Hughes Clarke and Brandon Maingot are adapting a method for rigorous estimation of the subtler integration error sources remaining in swath systems (wobbles, see Task 7) to this task.

The core research is designing an analytical equation, based on typical georeferencing models, which incorporates the geometric influence of the various potential unknowns (roll, pitch, heading, and time biases). This provides a means of defining the relationship between the relevant input (component position, orientation and their rates), the patch test parameters, and the integrated sounding positions.

Research associated with Task 7 saw the sensitivity of calibration parameters (integration errors), estimated by iterative least squares, to vessel motion and seafloor misfit when using simulated data. This sensitivity is expected only to increase when processing noisy field data. In the current reporting period Bayesian computational methods were investigated to identify a more robust means of estimation, and produce more reasonable confidence intervals on the estimated parameters, than iterative least squares. Research into a more sophisticated georeferencing model is also underway (see Task 7).

## THEME: 1.A.3: Innovative Platforms

### Sub-Theme: AUVs

**JHC Participants:** Val Schmidt

**Other Collaborators:** University of Delaware and numerous industrial partners.

In previous grants and reporting periods, the Center has pursued an active research program in autonomous underwater vehicles (AUVs) for hydrography. Analysis of the results, however, has suggested that such techniques, while possible, are not necessarily optimal for hydrographic practice. Particularly, the effort involved in managing a “pit crew” for typical AUV operations, precisely positioning the AUV, and then post-processing the results to generate hydrographic quality data means that there is little or no advantage over crewed launches with respect to the area covered, or personnel boarded on the host platform.

There are situations where AUVs make sense (e.g., covert operations, denied access, or high-resolution survey in deep water such as required by the Shell Ocean XPrize or cable/pipeline survey), but for conventional hydrography, their use appears questionable. In conjunction with NOAA operators and technology developers, and supported by experience in industry, we have therefore reduced effort on this research task, maintaining primarily a watching brief on system developments as we focus on the use of ASVs as the preferred autonomous hydrographic system.

### Sub-Theme: ASVs

**TASK 11: ASVs:** *Develop a suite of add-on sensors and payload processors capable of sensing the ASV's environment and the quality of its survey data in real-time, and adjusting its behavior (course, speed, etc.) to ensure safe, efficient operation. Also the use of ASVs for applications beyond hydrography, for example as smart mobile buoys. Applications include long-term monitoring of extreme weather events from within a storm, gas flux from seafloor seeps, monitoring of marine mammals, or dynamic and subsurface mapping of algal blooms. We also propose the development of a mission planning and vehicle monitoring application. PI: Val Schmidt*

#### Project: Hydrographic Surveying with Autonomous Surface Vehicles

**JHC Participants:** Val Schmidt, Andy McLeod, Roland Arsenault, K.G. Fairbairn, Coral Moreno, Lynette Davis, and Alex Brown

**Other Participants:** ASV Global Ltd., iXblue, Inc.

In an effort to fully evaluate the promise of autonomous surface vehicles (ASVs) for seafloor survey, and to add capability and practical functionality to these vehicles with respect to hydrographic applications, the Center has acquired, through purchase, donation or loan, several ASVs. The Bathymetric Explorer and Navigator (BEN) a C-Worker 4 model vehicle, was the result of collaborative design efforts between the Center and ASV Global LLC beginning in 2015 and delivered in 2016. Teledyne Oceansciences donated a Z-boat ASV also in 2016, and Seafloor Systems donated an Echoboat in early 2018. A Hydronaulix EMILY boat, donated by NOAA is in the process of refit. Finally, through the Center's industrial partnership program the Center has acquired 20 days per year of operation of the new iXblue DriX ASV.

These various vehicles provide platforms for in and off-shore seafloor survey work, product test and evaluation for these industrial partners and NOAA, and ready vehicles for new algorithm and sensor development at the Center. BEN is an off-shore going vessel, powered by a 30 HP diesel jet drive, is 4 m in length, has a 20-hour endurance at 5.5 knots, and a 1 KW electrical payload capacity. The Z-boat, Echo-boat and EMILY vehicles are coastal or in-shore, two-man portable, battery powered systems with endurances of 3-6 hours at a nominal 3 knots (sensor electrical payload dependent). The DriX is also an ocean-going vessel, with a unique carbon fiber hull, giving it a maximum speed exceeding 13 knots and endurance exceeding seven days at 7 knots.

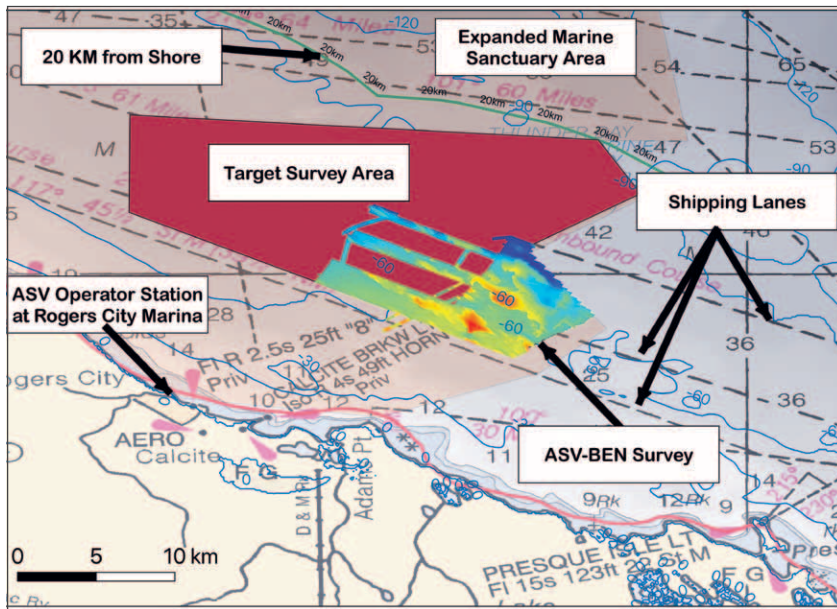

Figure 11-1. ASV-mapped area from the Thunder Bay National Marine Sanctuary Mapping Expedition. The ASV was operated from shore at Rogers City Marina, surveying between shipping lanes more than 10-25 km distant (data credit: OET/UNH-CCOM).

The marine autonomy group within the Center focuses on the practical use of robotic systems for marine science and in particular seafloor survey. Practical autonomy is defined here as the engineering of systems and processes that make operation of robotic vehicles safe, effective and efficient. These systems and processes are designed to mitigate the operational risk of an operation by increasing the

autonomy and reliability of its sensors and algorithms. Practical autonomy is viewed in a holistic way, including not only the safe navigation of the vehicle through the environment, but also the systems and processes that allow for unattended operation of sonars, data quality monitoring, and even data processing, and allow for operator-guided operation of these systems when necessary.

ASV operations in 2019 focused on collaborative expeditions using BEN with the Ocean Exploration Trust and testing of the DriX and sea trials on the NOAA Ship *Thomas Jefferson*. Working with the OET, the Center's ASV provided additional shallow water mapping capability operating either from shore or augmenting the deep-water capability

of the E/V *Nautilus* at sea. Expeditions were undertaken to Thunder Bay National Marine Sanctuary (May), American Samoan National Marine Sanctuary (July–August), and in the vicinity of Nikumaroro Island (August). Intensive testing of the DriX took place in September and October. Details of these events and the ongoing research and engineering involved are provided below.



Figure 11-2. The ASV Shore Command Center was created to operate ASV-BEN from the Lake Huron shoreline during the Thunder Bay expedition (lower two images courtesy of OET/Nautilus Live).



## Thunder Bay National Marine Sanctuary Expedition

In the spring of 2019, the ASV Group's focus was on critical updates to systems in preparation for a collaborative field program to search for shipwrecks with the Ocean Exploration Trust, NOAA's Office of Coast Survey, NOAA's Office of Ocean Coastal Science, and the NOAA Thunder Bay National Marine Sanctuary Figure 11-1).

Research objectives and engineering field tests conducted by the Center during the Thunder Bay mapping program included:

### Shore Command Center *(McLeod, Fairbairn, Arsenault and Schmidt)*

During the Thunder Bay mapping expedition the ASV was operated for the first time from a shore-based command center (Figure 11-2).

To support these operations the Center's ASV trailer was fitted with a custom folding antenna mast system elevating antennas more than 10 m above ground level, an AIS system for wide area vessel monitoring, a VHF radio for vessel communications, a PTZ camera with 30x optical zoom to improve situational awareness for operators and an uninterruptable power supply to ensure a temporary loss of shore power would not leave the operation crippled. Software was written to pan the PTZ camera to a selected map location and to optionally track the ASV, as well as to display AIS targets real-time. This new mode of operation posed all manner of challenges, including how to handle vehicle failures from shore, how to remain aware of the vehicle's immediate surroundings, how to monitor distant shipping traffic and plan safe passage well in advance of their arrival and how to anticipate and plan for loss of telemetry between the ASV and the command center. Learning to handle these situations opens up new possibilities with respect to shore-based ASV operations.

### Long Range Telemetry *(Schmidt and McLeod)*

To prepare for the expedition, the team procured and installed a Kongsberg Marine Broadband Radio telemetry system (Units 179 and 144), which had the potential to more than double the telemetry range of



Figure 11-3. ASV-BEN, conducting test of sustainable telemetry range with the Kongsberg Marine Broadband Radio telemetry system. Here the ASV is some 20 km from the operating station, approaching the center of Lake Huron. This range resulted from exceptionally favorable conditions. More typical maximum ranges were 14-16 km.

the existing system, to near 20 km (Figure 11-3). The system was installed and tested prior to arriving on site, but its first operational use occurred during the expedition. Routine telemetry ranges exceeded 15 km, with a link maintained beyond 24 km on one occasion (although this was atypical). Unpredictable failures of the 144 unit after prolonged operation proved operationally challenging and are under investigation.

### 360 Degree Camera System *(McLeod and Schmidt)*

The team added a five-camera system to augment the single factory installed camera system aboard the ASV (Figure 11-4). These cameras increase the operator's ability to remain aware of the vehicle's surrounding and to visually inspect contacts identified in radar and other sensors. Prototype algorithms for automatic object classification were run on these camera streams (see below). These cameras were tested operationally for the first time during this expedition, and were found to provide far superior awareness to the factory camera, but require tuning and re-engineering to manage their bandwidth consumption relative to other streams.



Figure 11-4. Operator's view of the three forward looking cameras of the five-camera system on board the ASV.

### LIDAR (Fairbairn and Moreno)

As part of these trials, the team installed a new lidar system. This system's 100 m maximum range provides relatively close-in sensing to identify immediate hazards to navigation. The Center collected preliminary data with this sensor to aid in algorithm development going forward for basic operator warning and collision avoidance.

### Power Monitoring and Control (Fairbairn, McLeod and Schmidt)

The team also installed a new payload power monitoring and control system to replace our initial system whose occasional past instability posed the greatest obstacle to autonomous mapping in the previous season. The new system increases the ASV's reliability and functionality by allowing individual loads to be remotely switched, and programmed for automatic operation, as well as monitored for power consumption. This functionality is critical for unmanned operations in which there is no operator to monitor and power cycle loads when required and the newly designed system operated reliably throughout the season.

### General Improvements to Project11 (Arsenault, Schmidt)

To provide a research and development environment for increased autonomy and functionality for our vehicles a marine robotics framework, dubbed "Project11," is being developed by Arsenault,

Schmidt, and others. Based on the widely popular Robotic Operating System (ROS), it is designed to be portable and work with the various autonomous vehicles in the Center's fleet. ROS provides a middleware layer allowing the various components, called nodes, to publish and/or subscribe to data streams and a framework for data logging and playback. The major components of the Project11 framework and data flows between them are illustrated in Figure 11-5.

Improvements to Project11 made during this year include: 1) modifications that improved the latency checking and error checking of User Datagram Protocol (UDP) data transfer mechanisms for unreli-

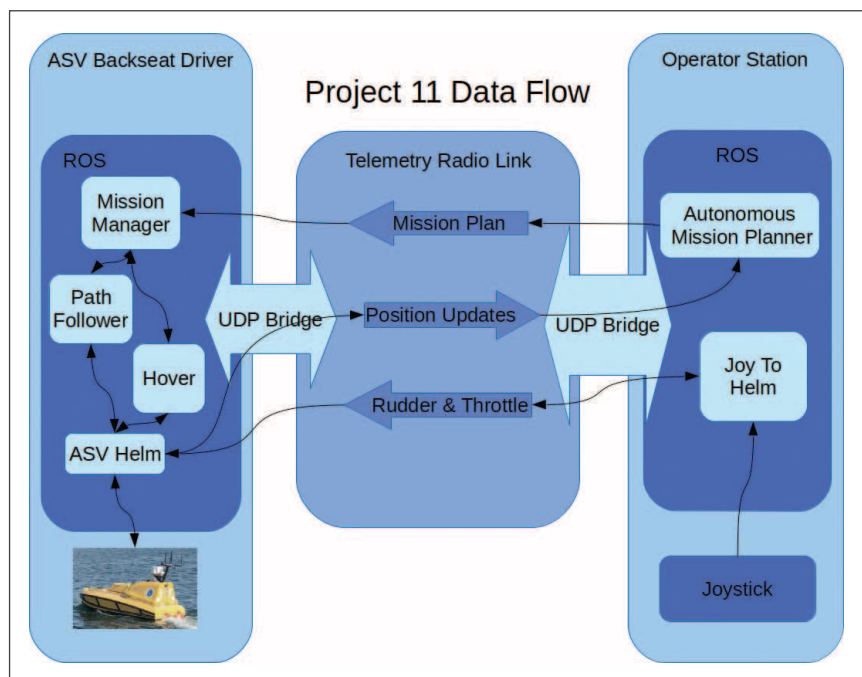

Figure 11-5. Conceptual drawing and data flow for the Center's "Project11" framework for marine autonomy.

able telemetry links; 2) new modularity that separates path generation from trajectory following and rudder/thrust interfaces with the vehicle(s), allowing graduate students and engineers to replace existing functionality with new algorithms and also add support for new vehicle interfaces piecemeal with minimal tweaking; 3) new simulator functionality that allows injection of moving contacts for object avoidance development; and 4) a new ability to speed-limit vehicles for additional safety when operating them within the Center's engineering tanks.

#### **Path Following Algorithm** (*Arsenault*)

The navigation of the ASV for mapping requires not only that the boat can be pointed in the direction of the next waypoint, but also that the boat can follow a line intersecting two waypoints with minimal cross-track error ( $< 2\text{m}$ ). This functionality was previously provided by an external software package whose performance was sub-optimal in cross-currents and so a new path follower routine has been designed and written. The new algorithm was tested in simulation this winter and again in preliminary field tests in Portsmouth in early 2019. The new algorithm was tested operationally for the first time during this mission and found to work exceptionally well.

#### **Vehicle State Machine** (*Arsenault and Schmidt*)

Robotic systems often use a "state machine" to provide various modes of operation for the vehicle and rules for transitioning the robot between those modes. Vehicle modes might include "STANDBY," "MANUAL," "IN MISSION," or "EMERGENCY." This functionality is still being developed within BEN and a new prototype design was trialed during these operations.

#### **Real-time Neural Network for Object Detection and Classification** (*Moreno*)

In recent years advances in methods for designing neural networks and the increased compute power provided by modern graphics cards have opened new possibilities for training and operationalizing these algorithms. One recently developed algorithm ("You Only Look Once" or YOLO) combines the ability to detect and classify objects in a camera image in a single pass, at speeds approaching video frame rates. As a preliminary trial, a YOLO implementation provided by Redmon et al., which has been trained

on only a limited number of classes, was installed on the ASV. The system was run on a newly installed NVIDIA Jetson TX2 computer, and provided real-time object detection and classification as seen by the ASV's new five-camera system. Evaluation of data collected during operations is underway to determine how to best optimize its performance.

#### **CPA Calculator** (*Moreno and Schmidt*)

A traditional first step in assessing the risk that another vessel poses to the ASV and determining a safe course of action is to calculate the closest point of approach (CPA) that will occur between them. To estimate the CPA in real-time, a new node within the ASV's Robotic Operating System was written and tested operationally during the expedition. This node will provide vital information for path planning algorithms in future work.

#### **SIS-5 Trial** (*Schmidt*)

Kongsberg has recently released new acquisition software for the ASV's EM2040P echosounder. The new software includes the "K-Controller" headless command interface, which for the first time will provide a complete software interface to the sonar suitable for autonomous systems, and a new operator's interface package, "SIS 5." In addition, with the new firmware comes a new sonar format—".KMALL." The Center evaluated this new software during the expedition, both operationally aboard the vessel and through the data processing pipeline. The Center trialed three successive releases of SIS-5, providing feedback and bug reports to Kongsberg with each, before finding it sufficiently stable for production operations. Unfortunately, the interface for remote control of the sonar remains incomplete and the KMALL format and its converter to the previous ".ALL" format remain not fully supported for backscatter processing.

#### **EM2040P MK II Upgrade** (*Schmidt*)

The Kongsberg EM2040P MBES aboard the ASV was upgraded this spring to the newly released MKII model. This model allows for increased swath coverage up to 170 degrees (200kHz and 300kHz only), well beyond the 120 degrees allowed by previous systems. The Center evaluated this system's suitability for operation aboard a small vessel and found increased sea states made it difficult to utilize the increased coverage.



## QINSY and Real-Time Qimera *(Schmidt)*

The Center also tested new data acquisition (QINSy) and post-processing (Qimera) packages provided by QPS b.v. aboard the ASV. These packages were tested in modes suitable for autonomous operations with the hope of allowing real-time monitoring of data acquisition by both operators through the telemetry link and artificial agents aboard the vehicle. Unfortunately, data archival requirements set by the NOAA Sanctuaries grant for the project prohibited data collection in proprietary formats and these systems could not be used during the expedition.

## Adaptive Survey *(Arsenault)*

The Center has previously developed prototype software for the automatic generation of survey lines based on previous data coverage. This code is being recast into a larger and more flexible robotic framework. There was insufficient time to test the revised code during these operations.

## Sonar Alignment System *(McLeod, Lavoie, Fairbarn, Schmidt)*

During the 2019 expedition to Thunder Bay, the ASV ran aground during survey of a wreck adjacent to the Alpena Marina jetty. The grounding weakened the ASV's sonar mount, allowing minute movement of the sonar when lowered into the deployed position and operating in rough weather. A new arrangement has been designed in which the mount is lowered into alignment pins ensuring the sonar returns to the exact location each deployment and that no movement of the sonar is possible. This system will be fabricated and installed in early 2020.

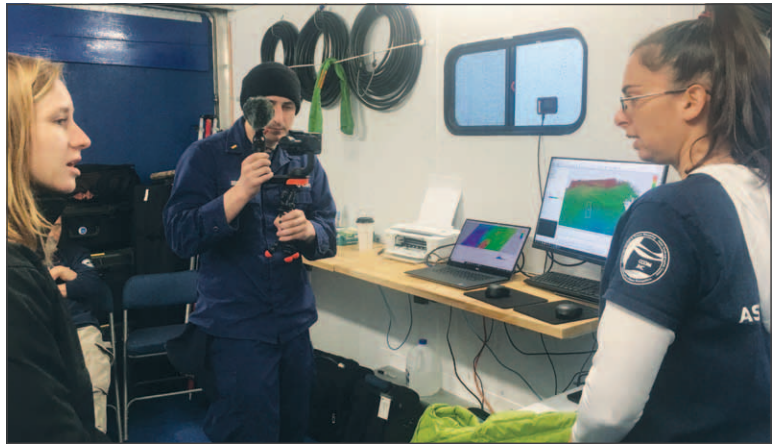

Figure 11-6. Ph.D. Student Coral Moreno explains multibeam sonar data during an interview by NOAA Education Specialist, Hannah MacDonald, during a Facebook Live Event. (credit OET/Nautilus Live).

## Outreach *(Schmidt, McLeod, Fairbarn, Arsenault, Moreno and Davis)*

Outreach is an integral part of any operation with the Ocean Exploration Trust, and the Thunder Bay mapping effort was no exception. The ASV and our crew were the center of attention during our visit to the marinas in Roger's City and Alpena, MI. Over the two weeks dozens of informal tours were provided to passers-by. During Regional MATE ROV competition, the control van was relocated to the Thunder Bay National Marine Sanctuary Campus and tours and demonstrations were provided to participants, their families, and the public. In addition, several formal events were arranged by NOAA and Ocean Exploration Trust personnel, including "Facebook Live" and "Google Hangout" events, tours for over 50 Eighth Graders from Roger's City, and interviews with two local television affiliates, which aired locally in mid-May.

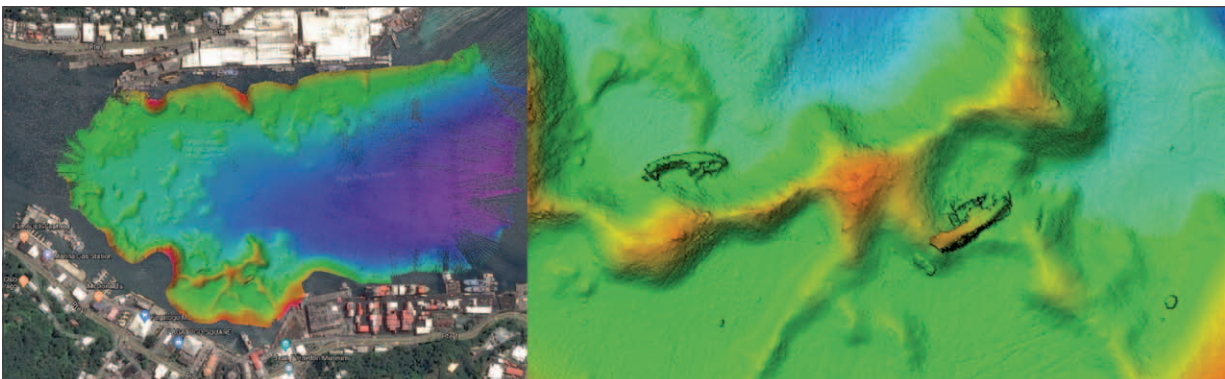

Figure 11-7. ASV Survey highlights from Pago Pago Harbor, American Samoa.

## American Samoa and Nikumaroro Island Expeditions *(Schmidt, Fairbarn, McLeod and Davis)*

Just one week after returning from the Thunder Bay expedition, the Center shipped BEN and associated gear to American Samoa for two weeks of survey operations in American Samoa National Marine Sanctuary followed by three weeks of survey in the vicinity of Nikumaroro Island to aid in the search for Amelia Earhart's missing Lockheed Electra aircraft. These expeditions were supported by the NOAA Marine Sanctuaries, the Ocean Exploration Trust and National Geographic.

ASV survey efforts began in American Samoa. Pre-underway system checks were conducted from shore in Pago Pago Harbor where numerous shipwrecks (some uncharted) from the area's 2009 tsunami were clearly evident in the data (Figure 11-7).

The team then deployed aboard the E/V *Nautilus* for a week of exploration within the American Samoan National Marine Sanctuary and associated islands. Surveys were conducted over shoals in the vicinity of Aunu'u Island that had been omitted from previous surveys due to wave conditions and nearby unexploded ordinance from a Japanese shipwreck (Figure 11-8).

After completing the American Samoa work, the E/V *Nautilus* set sail for Nikumaroro Island, a Kiribati atoll in the South Pacific where evidence suggests Amelia Earhart may have landed during her ill-fated around-the-world flight attempt in July of 1937. The E/V *Nautilus*, although equipped with sonar systems and ROVs for deep-water exploration was ill-equipped to survey the islands shallowest waters, and BEN provided this capability (Figure 11-9). Much of the survey

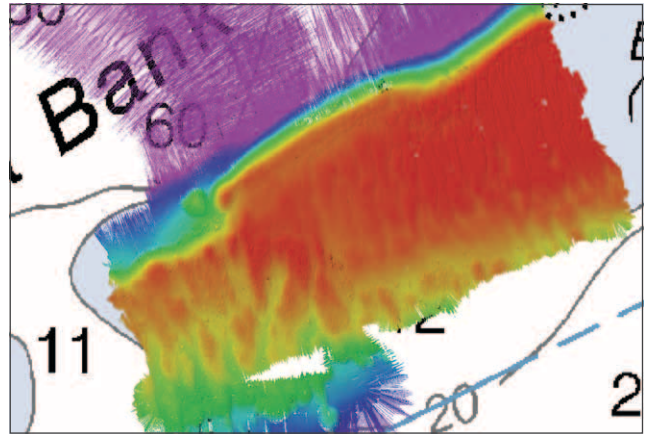

Figure 11-8. ASV BEN survey in the vicinity of Aunu'u Island, American Samoa.

work was directly adjacent to the surf break. Drones were flown to aid real-time piloting of the vehicle to provide situational awareness while mapping adjacent to the surf break. A drone can be seen hovering to the right of the ASV in Figure 11-9. In addition to sonar mapping with the BEN, the team provided both drone-based aerial imagery and ASV-captured underwater imagery to provide near seamless mapping coverage from the reef surf-break to the sonar data acquired by the ASV and ship (Figures 11-10 and 11-11).

Along with the mapping data, the team engineered inexpensive geodetic GPS units from OEM electronics in custom housings to provide a GPS reference station on the island and to create six roving GPS systems capable of logging raw observables. These systems were provided with GoPro cameras to archeologists going ashore allowing them to document the positions of any artifacts that might be found. Post processing of the GPS data allowed PPK positions of these artifacts with deci-meter uncertainty.



Figure 11-9. BEN preparing to survey in the vicinity of Nikumaroro Island, Kiribati, during the search for Amelia Earhart's plane.



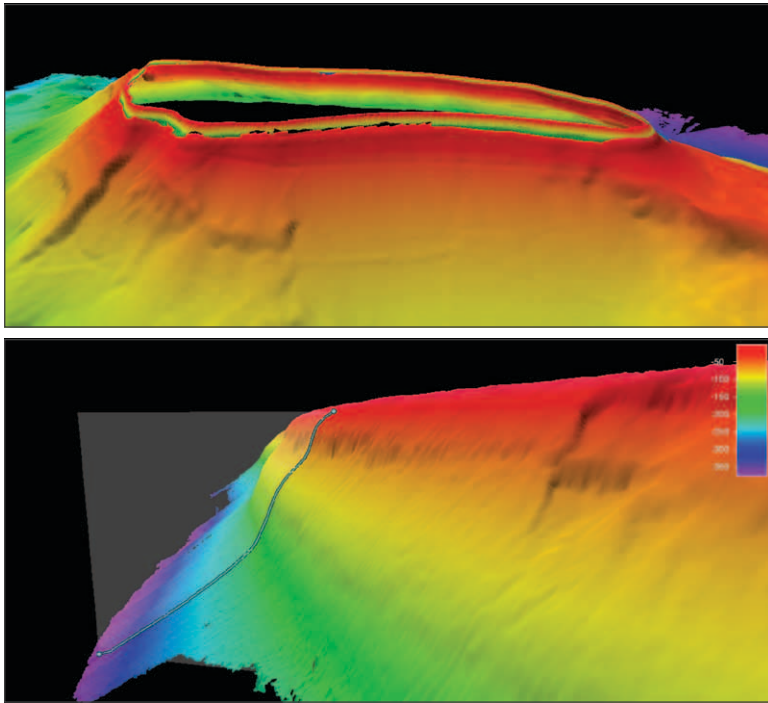

Figure 11-10. ASV Surveys at Nikumaroro Island provided critical high-resolution coverage in the shallowest waters. Slopes down the side of the atoll sometimes exceeded 45 degrees making survey and target detection exceedingly difficult.

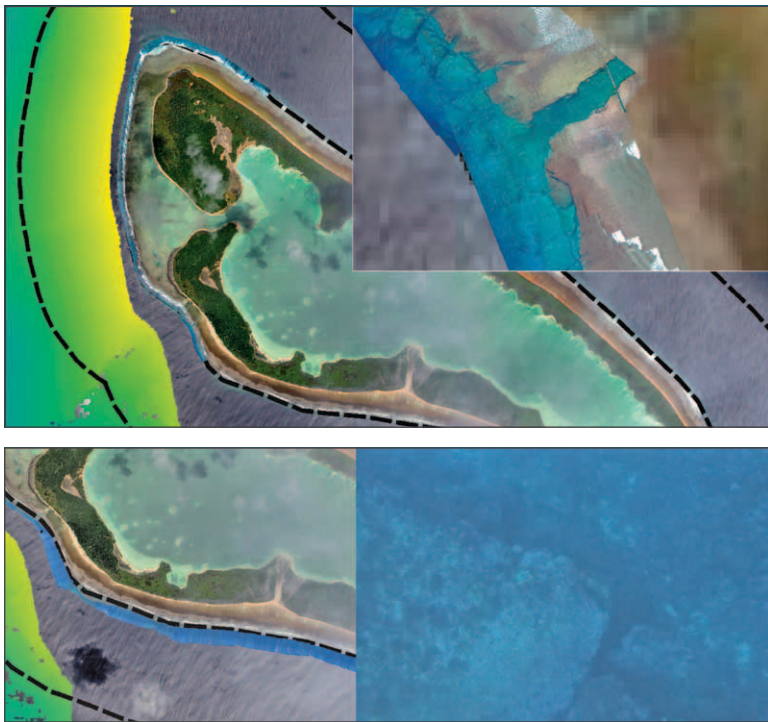

Figure 11-11. Aerial drone imagery (above) and ASV-mounted GoPro imagery (below) were used to fill the survey gap between the ASV's safe survey area beyond the surf break and the reef edge.

During survey operations aboard the E/V *Nautilus* in the South Pacific, the deployed ASV team was supported in real-time by Arsenault via the Center's Telepresence Console in Durham, NH. In a prototype test, ASV data was streamed to a local installation of the Center's mission planning software, CAMP, providing mapped location of the vessel and remote programming and control of the ASV on the other side of the globe. This was the team's first attempt at satellite ASV control.

**DriX Trials** (Schmidt, McLeod, Fairbairn)

The DriX ASV manufactured by iXBlue provides a unique platform for seafloor survey. Survey speeds of a large ship can be matched or exceeded by the vessel with equivalent data quality and multi-day endurance. For these reasons the Center has been partnering with iXBlue in sea-trials of the DriX and in collaboration for development of technologies to support autonomous operations.

This summer, in preparation for sea trials aboard the NOAA Ship *Thomas Jefferson*, iXBlue overhauled and sea-tested "DriX Hull 4" at the Center. Schmidt, Fairbairn and McLeod provided logistics, technical and at-sea support for these efforts (Figure 11-12).

In October, the Center facilitated DriX trials aboard NOAA Ship *Thomas Jefferson*, with Schmidt acting as liaison between the iXBlue team and the ship's crew. Efforts were focused on adaption of the ship's davit to accept the DriX Delivery System (DDS) and DriX, establishment of an ASV operations center aboard the ship, followed by several days test and development of recovery methods for various failures at sea (Figure 11-13). Integration paths of DriX-collected data were established with NOAA's acquisition systems, and operational survey models were evaluated with the ship both at anchor and underway, surveying in tandem with the DriX. Schmidt wrote draft handling and deployment procedures for the ship and an operational guideline for DriX operations from NOAA ships in future operations.





Figure 11-12. iXblue collaborators, Olivier Moisan, Camille Sales, and Antoine Diers aboard the Center’s R/V *Gulf Surveyor* during iXBlue post-overhaul trials of the DriX off the New Hampshire coast.

**Other Ongoing Work**

Other ongoing ASV projects (not tied to field programs) include advanced just-in-time path planning for ASVs and further development of the Center Autonomous Mission Planner (CAMP).

**Path Planning for Survey Coverage** *(Brown, Ruml, and Schmidt)*

The Center has been collaborating with computer science graduate student Alex Brown, and his advisor, Dr. Wheeler Ruml, since September 2018 to build a system for ASV path planning that optimizes line following for seafloor survey, while avoiding stationary and dynamic obstacles (Figure 11-14). Brown was brought on full-time as a graduate research assistant in May 2019.

Brown and Ruml designed a real-time motion planning algorithm for ASVs which optimizes for driving along survey lines while avoiding potential collisions. When integrated with the other software systems the Center has developed for controlling ASVs, an operator can specify a survey line or pattern through an intuitive graphical interface and a planner running the algorithm will determine the best trajectory,



Figure 11-13. Trials of the DriX ASV aboard the NOAA Ship *Thomas Jefferson*.

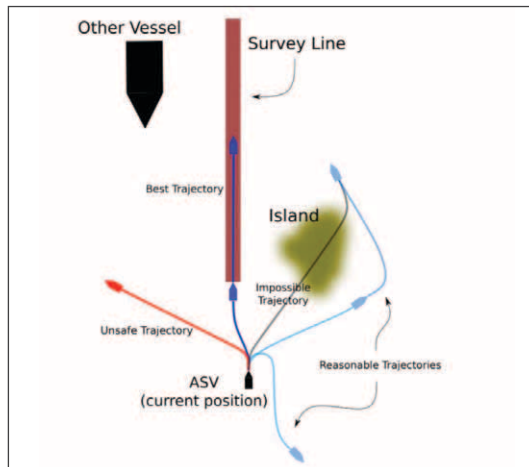

Figure 11-14. Conceptual drawing of the Real-time Motion Planning for Path Coverage algorithm, in which safe paths are sought that prioritize the survey mission.

out to a time bound, which follows the line without getting too close to any obstacles, and will update it every second. Brown and Ruml also worked with a computer science undergraduate to implement a model predictive controller suitable for controlling ASVs along trajectories generated by such a planner, and Brown has since integrated it into the Center's "Project11" framework. The system as a whole shows promise in simulation, but has yet to be field tested on any real ASVs.

### Enhancements to the CCOM Autonomous Mission Planner (Arsenault)

In addition, development continues by Arsenault on the CCOM Autonomous Mission Planner (CAMP) to

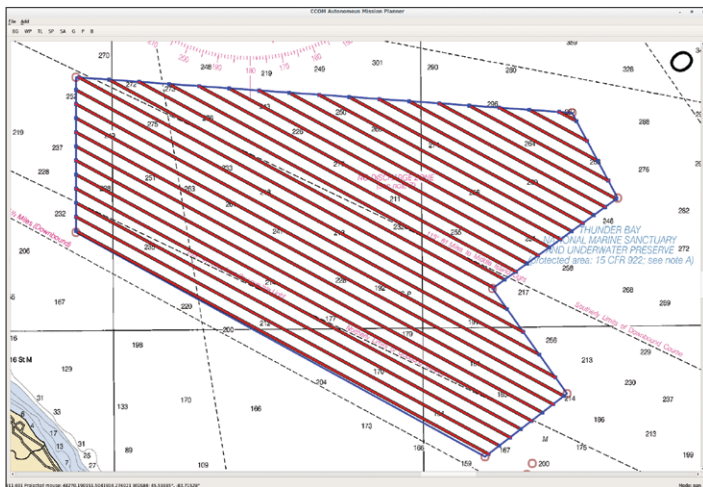

Figure 11-15. The CCOM Autonomous Mission Planner (CAMP) was enhanced with the ability to generate line plans within an arbitrary polygon to adapt to irregularly shaped survey areas.

improve usability and interface with new systems. Recent enhancements include:

- Support for displaying either a fixed or a mobile operator's station.
- Creation of a new general-purpose geographic plotting interface that allows any ROS node on the vessel to send collections of geographic points, lines and polygons, which are displayed in real-time on the operator's map in CAMP. For example, a new hover capability displays two concentric circles at the hover location indicating the drift and reposition radii. Vessels announced by AIS are now displayed in CAMP using the new plotting interface.
- A new hover mode has been added to CAMP, allowing the vehicle to "pause" a current mission either in place to at a specified location, and later resume the mission.
- It is now also possible to have fine control over how survey plans are executed through new operator controls. These include the choice of survey line to run, whether to run the line from the beginning or the nearest perpendicular intersection, reversing of a survey pattern and controlling the logging and ping-ing of the multibeam echo sounder.
- Since many survey areas tend to not be rectangular, the ability to specify a survey pattern within a polygon was added (Figure 11-15).
- Multiple mission elements may now be appended within CAMP to create a sequential list of tasks.
  - When operating from our mobile control lab, situational awareness was improved with the addition of a Pan/Tilt/Zoom (PTZ) camera on the roof allowing the scanning for traffic and monitoring of the vehicle. Tools were added to CAMP to point the camera in a direction specified by clicking on CAMP's chart display and ability to automatically track the ASV was also added with the help of a custom ROS node.
  - CAMP can now display the operator's position as either a fixed or moving location improving situational awareness.
  - An AIS receiver was added to the Center's mobile command trailer to improve on the range capability of BEN's receiver. New functionality was added to CAMP to display contacts reported by this receiver in CAMP.

## THEME: 1.A.4: Trusted Partner Data

**TASK 12:** *Develop a portable “trusted system” capable of generating qualified data using an incremental approach to the problem that would start with a desktop study of capabilities and requirements, followed by the design and build of an appropriate prototype system, and then a demonstration of its ability to interface with appropriate data repositories. PI: Brian Calder*

### Project: Trusted Community Bathymetry

**JHC Participants:** Brian Calder, Semme Dijkstra, Casey O'Heran, and Dan Tauriello

**Other Collaborators:** Kenneth Himschoot and Andrew Schofield, SealD

While it is tempting to assume that a bathymetrically-capable crowd of observers will emerge spontaneously for any given area (c.f. Task 34), and that there is a bathymetric equivalent of Linus' Law, most hydrographic agencies appear to be quite resistant to the idea of including what is variously termed “outside source,” “third party,” or “volunteered geographic” data in their charting product. Most commonly, liability issues are cited.

This is not to say that such data cannot be used for other purposes, or even for the production of “not for navigation” depth products (e.g., customer-updated depth grids in recreational chart plotters from, inter alia, Garmin and Navionics). Such things can and do exist. It does however appear that volunteered geographic information (VGI) is unlikely to be fully acceptable for hydrographic charting purposes in the near future.

As an alternative, consider a system where the data from a volunteer, or at least non-professional, observer is captured using a system which provides sufficient auxiliary information to ensure that the data does meet the requirements of a hydrographic office. That is, instead of trusting to the “wisdom of the crowd” for data quality, attempting to wring out valid data from uncontrolled observations, what if the observing system was the trusted component?

Brian Calder, Semme Dijkstra, and Dan Tauriello have been collaborating with Kenneth Himschoot and Andrew Schofield (SealD) on the development of such a Trusted Community Bathymetry (TCB) system, including hardware, firmware, software, and processing techniques. The aim is to develop a hardware system that can interface to the navigational echosounder of a volunteer ship as a source of depth information, but capture sufficient GNSS information to allow it to establish depth to the ellipsoid, and auto-calibrate

for offsets, with sufficiently low uncertainty that the depths generated can be qualified for use in charting applications. The originally proposed plan for this task was to develop such a system independently; collaborating with SealD, who already produce data loggers of this type and strongly interact with the International Hydrographic Organisation's Crowd-Source Bathymetry Working Group, is a more efficient route to the same objective.

Testing of the development system in previous reporting periods demonstrated that soundings can be resolved (with respect to the ellipsoid) with uncertainties on the order of 15-30cm (95%) and confirmed the accuracy and stability of a lower-cost (Harxon GPS500) antenna for the system. In the current reporting period, therefore, research has been focused on extensions of the system for auxiliary sensors, and observer ship horizontal offset calibration.

### Auxiliary Sensors

Having demonstrated the basic capabilities of the TCB system, expansions of the technique are now being considered. One very interesting research line is to consider auxiliary sensors that might potentially provide more useful information for hydrographic office use. Recent developments in the recreational sonar market have made available low-cost side-scan sonar systems, which might potentially allow for hydrographic offices to benefit from imagery of targets and obstructions in the vicinity of TCB observers, and even to have the system automatically log imagery in the vicinity of targets of interest specified by the hydrographic office and disseminated to the TCB system during data exchanges. Additionally, the availability of high-resolution sidescan imagery may provide valuable datasets for habitat mapping, geological mapping, and for detecting non-hydrographic targets in the water column, such as fish.



Calder, Semme Dijkstra, and graduate student Dan Tauriello are therefore investigating the implications for this idea with respect to the TCB system, and are developing a demonstrator system, and concept of operations. After a thorough audit of existing side-scan modules suitable for integration with a TCB system, it was discovered that no published network protocol exists for interacting with a commercially available unit. Therefore, Dan Tauriello has focused his efforts on reverse engineering the Garmin GCV-10 SideScan module, which is sold for approximately \$500—with transducer included—and can produce high-resolution single beam and side scan imagery at 455 kHz and 800 kHz.

As is common with many modern, high resolution, sonar systems, the Garmin GCV-10 communicates with the chart plotter using proprietary TCP and UDP Ethernet protocols, instead of NMEA sentences. So far, code has been developed to allow for direct control of the Garmin GCV-10 unit functions using a simple Python package installed on a Linux-based workstation. Device power, gain, frequency, range, and toggle between side scan and single beam modes are all controllable by a TCB datalogger computer when connected with a single Ethernet cable.

In order to decode and reassemble the sonar's imagery data, Tauriello has conducted a number of experiments with the GCV-10 aboard R/V *Gulf Surveyor* as well as in the Chase Ocean Engineering Lab test tank (Figure 12-1). In these experiments a variety of targets are imaged using the available range of sonar settings, and the raw data is recorded, parsed, and visualized using MATLAB code under development (Figure 12-2). Now that the sidescan image can be properly reconstructed a tool is being developed to convert proprietary formatted Garmin GCV-10 data to a 'hydrographically friendly' format such as XTF, in order to allow for data analysis in industry standard software packages. The research is on-going.

### Horizontal Offset Calibration

The prototype TCB system has previously been shown to be able to auto-calibrate the vertical offset between the GNSS antenna and the echosounder being used to report depth, at least to within the uncertainty required to produce useful soundings. Depending on the size of the vessel and installation method, however, horizontal offsets between the antenna and echosounder may become significant in the accuracy of the soundings just as it would for a conventional survey system. Quickly determining the horizontal offsets is therefore of interest for improving the quality of TCB data.



Figure 12-1. Development of a TCB interface for a recreational-class sidescan sonar. In order to determine where particular components of the data appear in the network packets, a sealed (highly acoustically reflective) PVC pipe was used (a) to affect the output of the sonar (b).

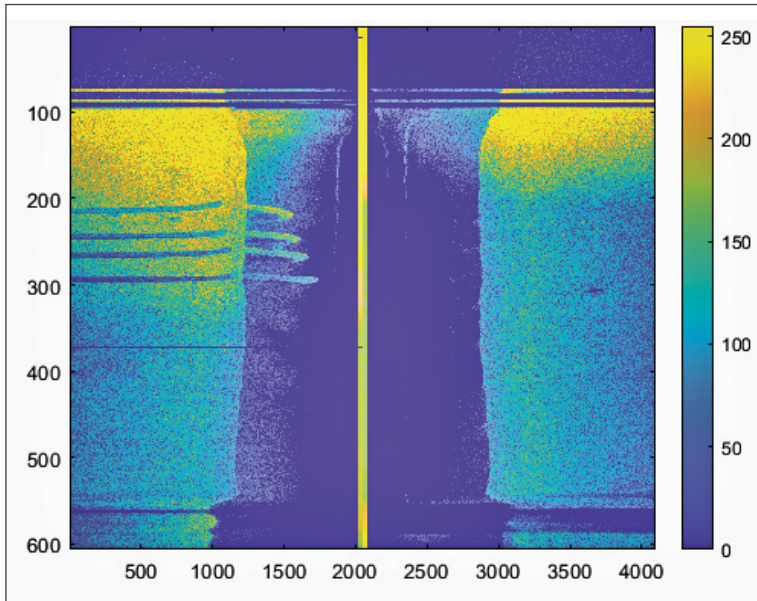

Figure 12-2. Reconstructed Garmin GCV-10 side scan imagery using MATLAB code. Four bridge pilings are readily visible water column targets on the port side. The transducer was lifted out of the water causing data loss near the top of the image.

Calder and graduate student Casey O’Heran have therefore begun research on how to resolve accurate horizontal offsets on survey vessels using non-traditional survey methods. One method being considered involves estimating the vessel’s horizontal offset between the GNSS receiver and the sonar using an authoritative seafloor model as reference. Using SealD GNSS receivers, the vessel would collect data over a defined feature that has already been observed. By comparing the observed data to the known data, the horizontal offset value could be estimated in a manner similar to a standard patch test, except that one half of the “patch” is pre-determined by an already calibrated system. In the current reporting period, however, the primary investigation has been in surveying a vessel with photogrammetry and lidar from an Unmanned Aerial Vehicle (UAV).

As an initial matter, to conduct any research utilizing a UAV, a certified UAV pilot must fly the UAV or be present when the UAV is being used to conduct official research. O’Heran thus got his Part 107 UAS certification from the Federal Aviation Administration (FAA) in February of 2019 to fly official research flights for this project.

In order to develop the techniques required for offset determination and provide a quantification of the accuracy of the methods, the R/V *Gulf Surveyor* was used as a test target. *Gulf Surveyor*, the Center’s primary survey and research platform, was surveyed using terrestrial lidar in 2016, providing a ground-truth for the methods, and is extensively monumented, allowing for multiple comparison points across the topside of the vessel.

A primary concern with this method is to determine what level of survey accuracy can be achieved by different sensing modalities, and thereby to determine the cost-performance trade-offs for the technique. (Volunteered geographic data collection can be extremely cost sensitive, so understanding complexity/cost trade-offs is important.) To provide a high-specification survey, a local engineering company called ARE was hired to conduct a lidar survey of the *Gulf Surveyor* while it was docked at the UNH pier on New Castle Island, New Hampshire on April 17, 2019. A DJI Matrice UAV was flown with a Riegl lidar sensor, while Aeropoint ground control points (GCPs) were deployed on the surface of the pier. In addition to the Aeropoints, several paper Secchi targets were placed on the *Gulf Surveyor*. Several passes at different heights above ground were

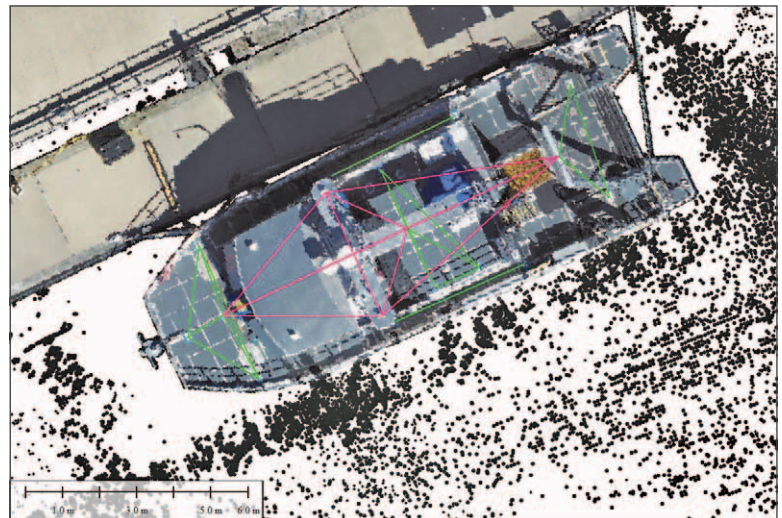

Figure 12-3. Point-cloud for the R/V *Gulf Surveyor* constructed using aerial LiDAR from a DJI Matrice UAV at multiple altitudes. Note the lines joining survey monuments (purple) and Secchi targets (green), which are measured in the point cloud to assess the technique.



flown over the course of the lidar survey. The data was processed by ARE and was further analyzed by O’Heran using Global Mapper. The lidar point cloud was colorized using aerial imagery taken on the same day that the lidar survey was executed. Using an at-nadir view of the point cloud, polylines were placed on designated targets within the model, Figure 12-3. Measurements from the model were then compared directly to the respective ground truth distances from the 2016 laser scan survey. MATLAB was employed to compute/plot the differences between the ground truth and observed target distances. It was found that the UAV lidar method achieved errors on the centimeter level.

To provide a cheaper alternative for comparison, a photogrammetry survey of the *Gulf Surveyor* was conducted on the same day. O’Heran flew a DJI Phantom 4 Pro with a 20-megapixel camera over the survey area at different flying heights and in different flight patterns while the vessel was tied down snugly with extra lines. Data from the photogrammetry survey was then brought into Agisoft Metashape and a structure from motion (SfM) algorithm was applied; a number of different combinations of datasets have been considered to determine recommended capture methodologies, and the achievable uncertainties. Uncertainties from the first experiment were determined by constructing a point cloud, Figure

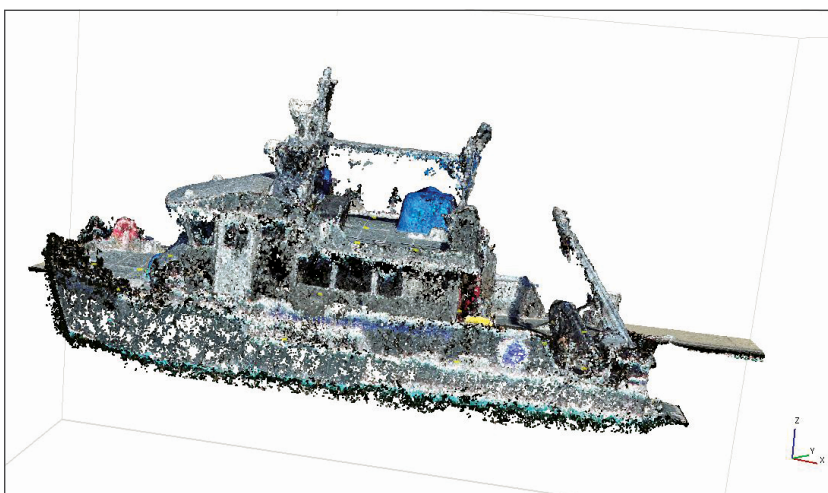

Figure 12-4. Point-cloud for the R/V *Gulf Surveyor* constructed using Structure from Motion (SfM) techniques applied to the drone photogrammetry survey at an altitude of 31m.



Figure 12-5. Orthomosaic of the R/V *Gulf Surveyor* corresponding to the point-cloud of Figure 12-3. Note the lines joining survey monuments (purple) and Secchi targets (green), which are measured in the orthomosaic to assess the technique.

12-4, and orthomosaic, Figure 12-5, and then comparing measurements from the models to the ground-truth laser survey. Initial error estimates in the photogrammetric offsets were on the centimeter level with Ground Control Points (GCPs) and decimeter level without GCPs. Multiple models of the vessel were produced with a varying number of GCPs to determine the effect decreasing the number of GCPs has on the error estimates for the respective model. No significant change in error estimates were experienced when going from eight to three GCPs. To prove that this level of accuracy can be achieved using SFM photogrammetry on a consistent basis and to further understand how uncertainties are introduced in this type of survey, four more experiments were conducted.

To prepare for the succeeding photogrammetry flights, ten nylon survey targets were secured to the UNH pier and were surveyed with a Trimble 5700 receiver with a zephyr antenna on August 6, 2019. Photogrammetry flights were then conducted from August 21–23, with the conditions and flight patterns of these experiments being simulated to closely match the respective properties of the April 2019 experiment. However, unlike the first experiment, the August 21 flight was performed with the vessel “loosely”



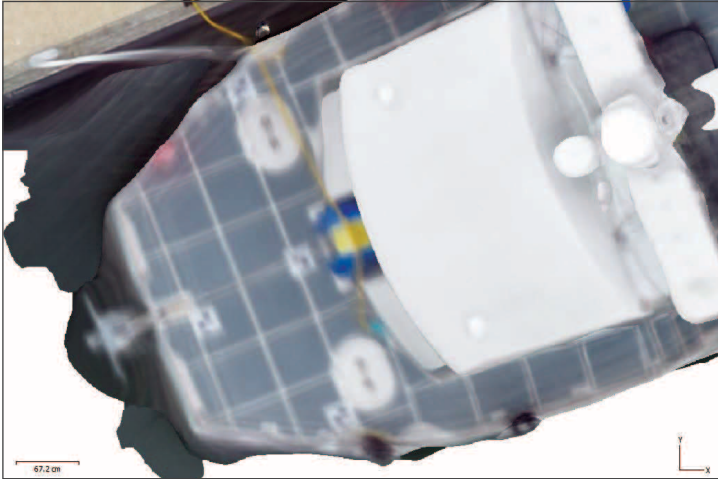

Figure 12-6. Close up of an orthomosaic of the R/V *Gulf Surveyor* created from the August 21, 2019 dataset. The blurriness seen on the deck of the vessel makes it difficult to locate objects on the vessel with a high degree of accuracy.

tied down. This was done to quantify the effect introducing more motion on the vessel has on the error estimates of the survey. The orthomosaic created from this particular dataset turned out very blurry in comparison to the original and succeeding experiments, Figure 12-6. The significant blurriness in this orthomosaic makes it extremely difficult to identify the appropriate targets required to make measurements on the vessel. In addition to the blurriness, high error estimates were observed in this model. To investigate whether the vessel motion caused this,

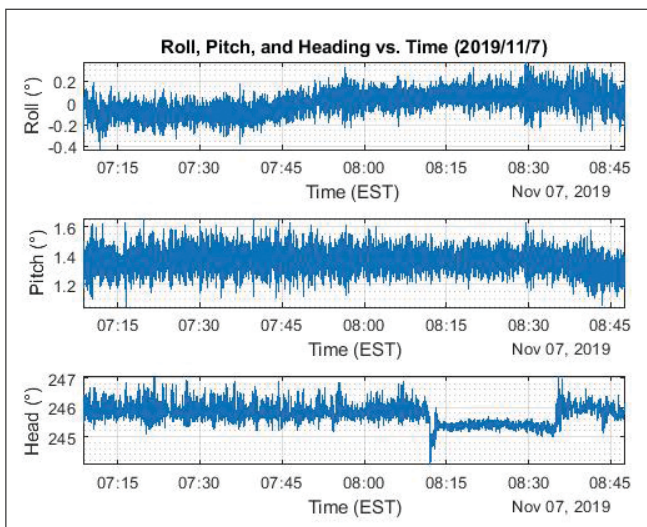

Figure 12-7. Roll, pitch, and heading of the R/V *Gulf Surveyor* during the November 7, 2019 flights. The vessel was tied down tight from approximately 0813-0835.

the POS MV data that was collected on board the vessel during the flights was analyzed. Initial analysis in MATLAB of the attitude data showed that the heading was changing much more throughout the flight on August 21 than in the flights performed on other days.

This phenomenon was explored further with one last set of flights on November 7, 2019; when two flights were conducted with the vessel loosely tied down and a third performed with the vessel tied down tight. In the loosely tied down flights, the orthomosaics were blurry, similar to the August 21, 2019 dataset. The attitude data displayed in Figure 12-7 demonstrates the difference in motion that the vessel underwent when it was loosely tied down compared to being tightly tied down during the November 7 flights. It can be seen from the figure that the heading experienced

the most significant change when transitioning from a loose to tight tie down setup, as opposed to the roll and pitch. To quantify how much the motion is affecting the quality of the survey, MATLAB code was created to compute the number of pixels the vessel shifts during a set number of time/photos. As shown in Figure 12-8, there is a stark difference in the size of the shift when loosely and tightly tied down. As the vessel was tied down tighter, the change in heading decreased, lowering the degree of pixel shift, thus resulting in a cleaner orthomosaic.

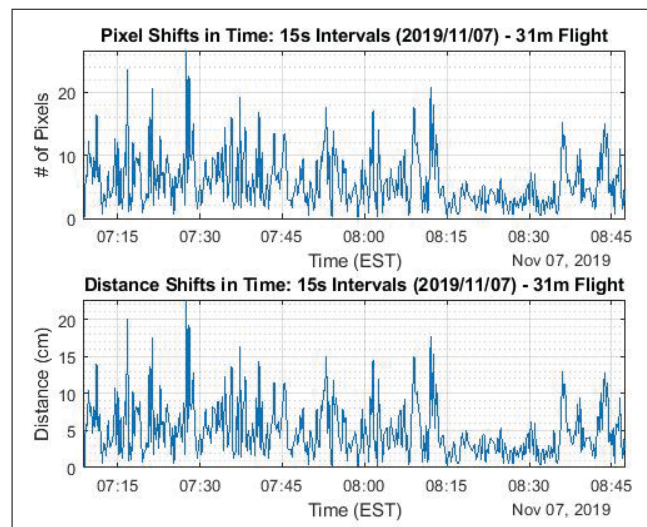

Figure 12-8. Pixel shifts that the R/V *Gulf Surveyor* experienced, every 15 seconds, during the November 7, 2019 flights. This calculation was performed using the attitude data from Figure 12-7, flying height, camera characteristics, and a known monument location in the Ship's Reference Frame (SRF).

Based on this discovery, it is recommended that when performing this type of calibration survey, the vessel should be tied down as tight as possible to limit the potential for both blurriness in the orthomosaic and high error estimates.

With the conclusions of both the motion investigation and UAV photogrammetry experiments, a complete analysis of the survey accuracies began. Figure 12-9 puts into perspective the scale of the general errors for this type of vessel calibration. As seen in the first experiment, using GCPs consistently results in error estimates at a centimeter level. It is also important to note that the UAV lidar method results in a very similar error estimate as the SfM photogrammetry method. In some cases, the SfM photogrammetry models even appear to have slightly lower error estimates than the UAV lidar method. This means that a consumer grade drone can achieve the same level as accuracy for a vessel calibration survey as an industrial drone equipped with an expensive lidar sensor. Thus, for this application, it would be advantageous to implement the SfM photogrammetry method over the UAV lidar, as it is less expensive and more intuitive to operate.

On a basic level, the analysis derived from Figure 12-9 is very useful. However, this analysis only looks at comparing direct distances between targets, rather than the cartesian components in the Ship's Reference Frame (SRF), which are required for full understanding. To allow for this analysis, the observed SfM coordinates were transformed to the *Gulf Surveyor's* SRF by establishing the x-axis of the observed model in WGS 84 UTM 19N and rotating it by the heading from North. This is the recommended procedure for establishing an SRF when performing a vessel calibration with a UAV. Analysis of the cartesian errors is ongoing.

A number of factors have been found to impact the uncertainties achieved, including motion of the vessel over the duration of the flight, and the stage of the tide at the time of survey. After conducting several flight missions, the Standard Operating Procedures (SOP) have been fine-tuned and the recommendations for conducting a UAV survey of a vessel while it is docked in water have become clear. In the upcoming reporting period, focus will shift towards exploring the seafloor reference method. The end goal of this research is to fully assess and compare the results of all three proposed vessel calibration methods.

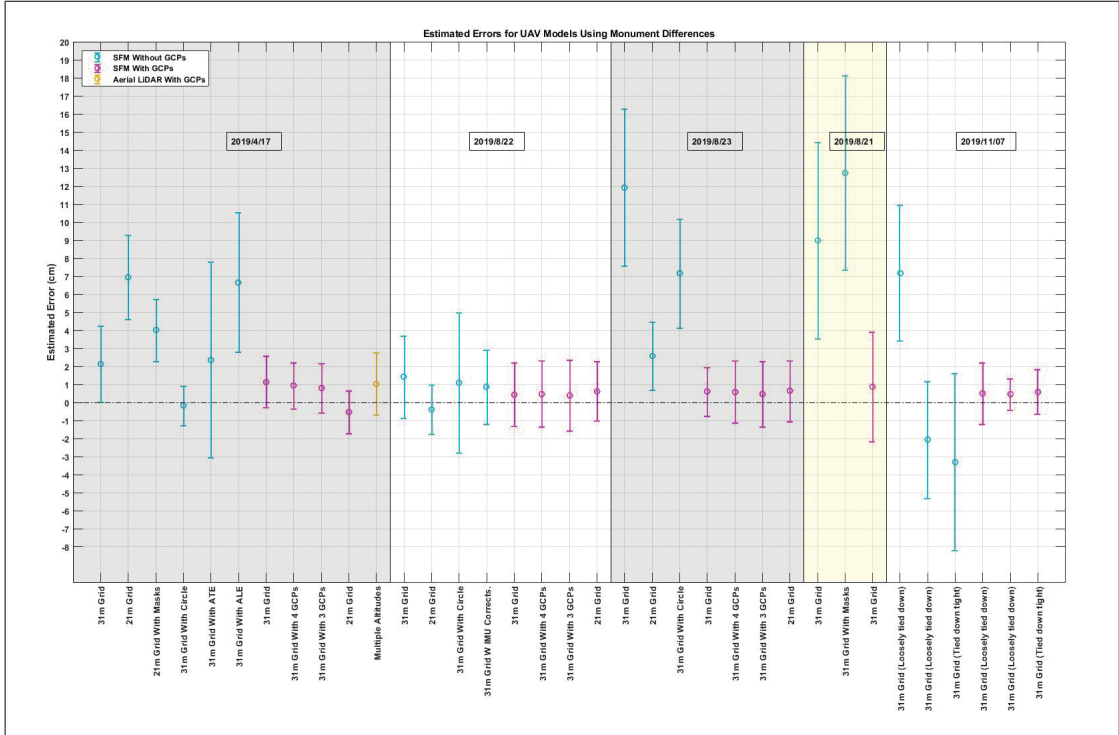

Figure 12-9. Error estimates for all SfM photogrammetry datasets. These error estimates were calculated by subtracting the observed monument baselines from the ground truth laser scan baselines.

## Research Requirement 1.B: Data Processing

**FFO Requirement 1.B:** “Improvement in technology and methods for more efficient data processing, quality control, and quality assurance, including the determination and application of measurement uncertainty, of hydrographic and ocean and coastal mapping sensor and ancillary sensor data, and data supporting the identification and mapping of fixed and transient features of the seafloor and in the water column.”

### Theme: 1.B.1: Algorithms and Processing

#### Sub-Theme: Bathymetric Processing

**TASK 13:** *Continued development of CHRT and like algorithms, with particular attention to the use of slope information, correlations between measurements, and refinement techniques for variable resolution grids. For alternative bathymetric data processing techniques, we will explore non-parametric methods, non-uniform sampling methods, and non-local context for decision-making. We will also continue our development of parallel and distributed processing schemes, with particular emphasis on practical application of local-network distributed-computing, distributed-storage, and cloud-based environments. Finally, we will investigate better user-level algorithm completeness and skill metrics that provide stable, reliable, and visually impactful feedback for data quality assurance. These efforts will be coordinated with our visualization team to ensure that the final products impart data quality parameters in a manner that is easily interpretable. PI: **Brian Calder***

#### Project: CHRT

**JHC Participants:** Brian Calder, Matt Plumlee, and Kim Lowell

**Other Collaborators:** Kari Dempsey, David Stephens, and Thomas Redfern (UKHO)

Despite advances in processing techniques and technology in the last decade, processing of large-scale, high-density, shallow-water hydrographic datasets are still a challenging task. JHC/CCOM has pioneered a number of techniques to improve on the processing times achievable, and new technologies that have conceptually redefined what we consider as the output of a hydrographic survey. There is, however, still some way to go.

The CHRT (CUBE with Hierarchical Resolution Techniques) algorithm was developed to provide support for data-adaptive, variable resolution gridded output. This technique provides for the estimation resolution to change within the area of interest, allowing the estimator to match the data density available. The technology also provides for large-scale estimation, simplification of the required user parameters, and a more robust testing environment, while still retaining the core estimation technology from the previously-verified CUBE algorithm. CHRT is being developed in conjunction with the Center’s Industrial Partners who are pursuing commercial implementations.

Although the core CHRT algorithm is in principle complete and has been licensed to Center Industrial Partners for implementation, modifications, some significant, continue to be made as the research pro-

gresses. In the current reporting period, for example, we have assisted a number of Industrial Partners with parameter configurations, and provided tools to assist with survey edge effects to NOAA for implementation in HydrOffice/Pydro.

#### Level of Aggregation Estimation of Resolution

In its original implementation, the CHRT algorithm used data density as a proxy for achievable resolution of a gridded data product; the data density was estimated by computing the area insonified by the sounder over a coarse resolution grid, the cells of which were then piecewise replaced with higher resolution grids over which the final depth estimation was computed. This coarse-to-fine refinement is efficient and convenient, but requires the user to specify the coarse resolution (which is not necessarily an obvious choice), and relies in implementation on the swath nature of multibeam echosounder data, making it unsuited for single-beam, mixed point data, or (most) lidar data. It is also difficult to construct reliably and hard to parallelize for computational efficiency.

Motivated by the need to process high-density topobathymetric lidar data (see Task 17) using CHRT-like methods, Calder designed an alternative scheme which works fine-to-coarse, estimating the level at which high-resolution cells need to be aggregated in



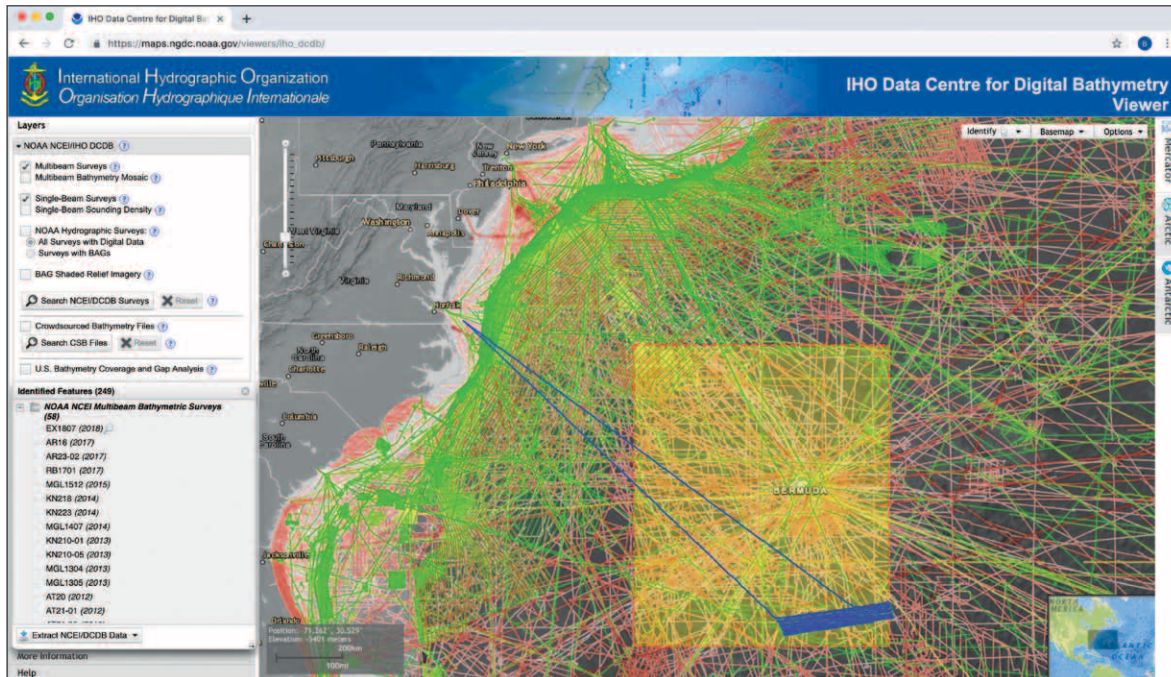

Figure 13-1. Datasets from the National Centers for Environmental Information (NCEI) for the area surrounding Bermuda (highlighted area: 62-70W x 28-36N). Tracklines from all singlebeam (tan lines) and multibeam (green lines) surveys are shown. The highlighted line is from a recent NOAA Ship *Okeanos Explorer* survey (EX1807).

order to ensure that there will be a sufficient number of observations in the area to reliably estimate the depth (in practice, this is the actual computation that CHRT was always doing, using data density as a proxy). Due to this basic mechanism, the technique is called “Level of Aggregation” (LoA) analysis. In the last reporting period, Calder adapted this technique to acoustic data, and demonstrated that it achieved comparable results to prior methods, at competitive processing rates after core-parallel optimization. In the current reporting period, LoA analysis has been adapted to the question of computable completeness of surveys.

Although knowing when a survey is “done” is important for any hydrographic unit, a computable sense of completeness is particularly important for autonomous systems where algorithms need to be able to determine whether the data collected so far is sufficient for purpose. Similarly, projects such as Seabed 2030 need to be able to determine whether the data holdings to hand are sufficient to achieve their goals. Such issues are closely related to the estimation of resolution: if the resolution supportable by the data is computed (given suitable assumptions on what constitutes “supportable”), then a compari-

son against the required resolution (as specified by survey standard) can quickly determine where data collection is “complete.” Areas of incomplete data can then be identified and used to guide further collection or rework.

To demonstrate this idea, consider the area of the Atlantic around Bermuda, Figure 13-1. While compelling, visualizations such as this are often misleading, because each trackline must be shown as at least a one-pixel line, which may be a significant size if the visualization is zoomed out to a sufficiently small scale. This tends to make it appear as if there is more data than there really is.

To apply the LoA analysis to this data, a minimum resolution of 25m and maximum of 3,125m were selected (the latter selected automatically by the algorithm from the data), and the algorithm was configured to require at least five observation to be judged “stable,” and allowed for up to 20% of the observations to be noise. This is intentionally pessimistic, and considerably more than Seabed 2030 requires, but is not unrealistic for reliable determination of depth in areas with data reaching back over 50 years.

The results of this analysis, Figure 13-2, clearly demonstrate just how much of the seafloor is considered “unsurveyed” (i.e., there is not enough data to make any reliable assertion of depth, irrespective of the required resolution) under these assumptions. For the areas where a reliable depth can be determined, however, the resolution required by the Seabed 2030 project is 100m to 1,500m depth; 200m from 1,500-3,000m depth; 400m from 3,000-5,750m depth; and 800m below 5,750m. Using the low-resolution depth estimates from CHRT, Figure 13-3(a), required resolutions can be computed, and then compared with those predicted from the data, Figure 13-3(b). Examination of Figure 13-3(b) demonstrates that no area with single beam coverage is considered complete under the given assumptions (although depths are still generated since CHRT will estimate depths even with a single observation—just not reliably), and even some areas of multibeam coverage are insufficient to support the desired resolutions. For example, there are a number of cases where MBES tracklines partially meet the requirement (e.g., in the inner swath), and some where none of the data meets current requirements (see, for example, the northwest corner of the area in Figure 13-3(b)). This MBES data is a legacy of first-generation commercial deep-water MBES systems from the 1980s, where there were many fewer beams across the swath than is now typical, and therefore lower data density to support higher resolution depth estimation.

Efficiency in algorithms such as this is important. The LoA solution, since it is computed solely from a grid of occupancy counts, can be readily updated as new data is added to the database, so long as the count grid is preserved. For scale, allowing that computation time will vary significantly with implementation and hardware, the full refinement computation (post count-grid constructed) here was approximately 17.5s (Intel Core i7 processor at 4GHz, 32GB memory and SSD-fronted hard disc) with grid dimensions (35,623 x 41,864) cells, demonstrating the algo-

rithm can be implemented with low overhead (the time required to read the raw data in order to create the count grid is significantly longer than the computation time). This makes re-running the refinement resolution computation occasionally a low-cost event and making real-time updates feasible.

### Distributed Processing for CHRT

In the last two to three years, there has been greater interest in distributed, embedded, and cloud-based hydrographic data processing, embodying processing paradigms proposed by the Center since 2007. While the current version of the CHRT algorithm has a multi-threaded (i.e., single processor parallel) computation mode, and some experiments have been conducted previously to examine how the algorithm might be distributed, it is by no means clear how the algorithm should best be adapted to these types of services. In the current reporting period, therefore,

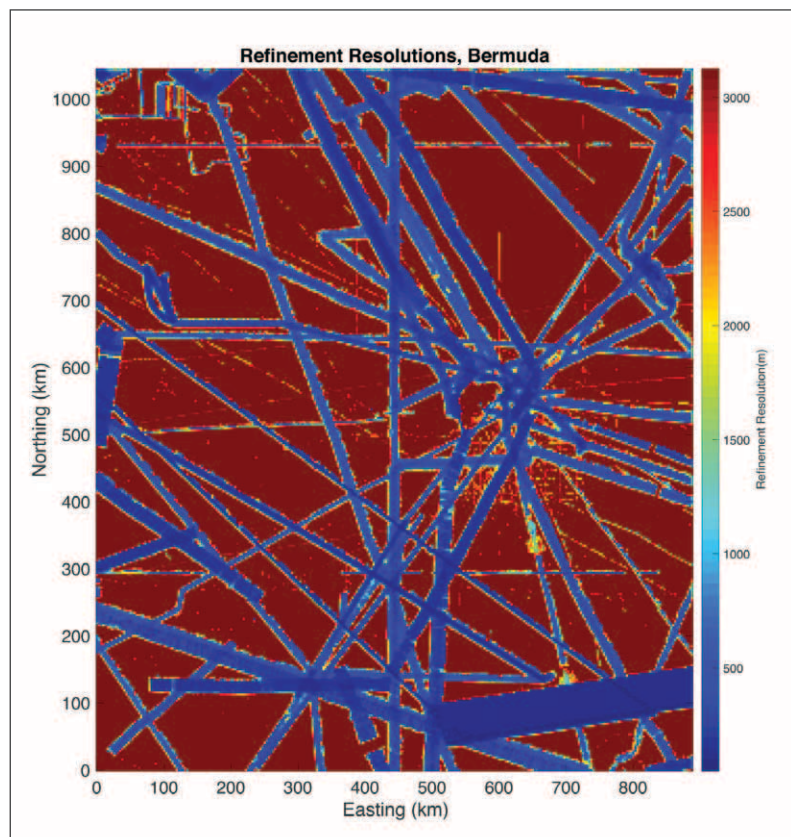

Figure 13-2. Estimates of achievable depth estimation resolution (assuming five observations for stability and allowing 20% noise) corresponding to the highlighted area of Figure 13-1. Note that much of the area is set to 3,125m, indicating that there is insufficient data to support stable depth estimation.



Plumlee and Calder have continued efforts to design a version of CHRT that could be distributed onto a loosely-coupled symmetric computing cluster, which would be ideal for implementation in a cloud service, or through a local compute cluster (e.g., a blade server or small server farm). The current design uses the Message Passing Interface (MPI), a standard approach to distributing tasks across large and scalable clusters, to split the computation across multiple nodes, each of which can cache intermediate results and therefore increase both compute and network bandwidth available to the algorithm.

In the current reporting period, a distributed version of the first phase of the CHRT algorithm has been demonstrated and the design and implementation of the second phase, and particularly the scheduler, have been significantly advanced. We have also opened discussions with a provider, and a potential provider, of cloud-based hydrographic data services on the potential for a proof-of-concept demonstration of CHRT in the cloud.

## Machine and Deep Learning for Data Processing

In conjunction with the work reported in Task 17 on lidar data processing, Calder and Kim Lowell have initiated a collaboration with the United Kingdom Hydrographic Office's Data Science program to investigate modern machine and deep learning techniques for the processing of bathymetric data. Both organizations have submitted a publication for review on the topic, and have outlined a joint development and publication which would advance the collaboration. The initial collaboration builds on joint experience in data modeling and test, with the intent of integrating CHRT-like algorithms with the point-data classification developed within UKHO and the metadata analysis (see Task 17) developed at the Center. It is expected to lead in the future to algorithms that assess their own success as part of the processing, and which can benefit from operator-mediated in-processing learning opportunities (which are currently discarded).

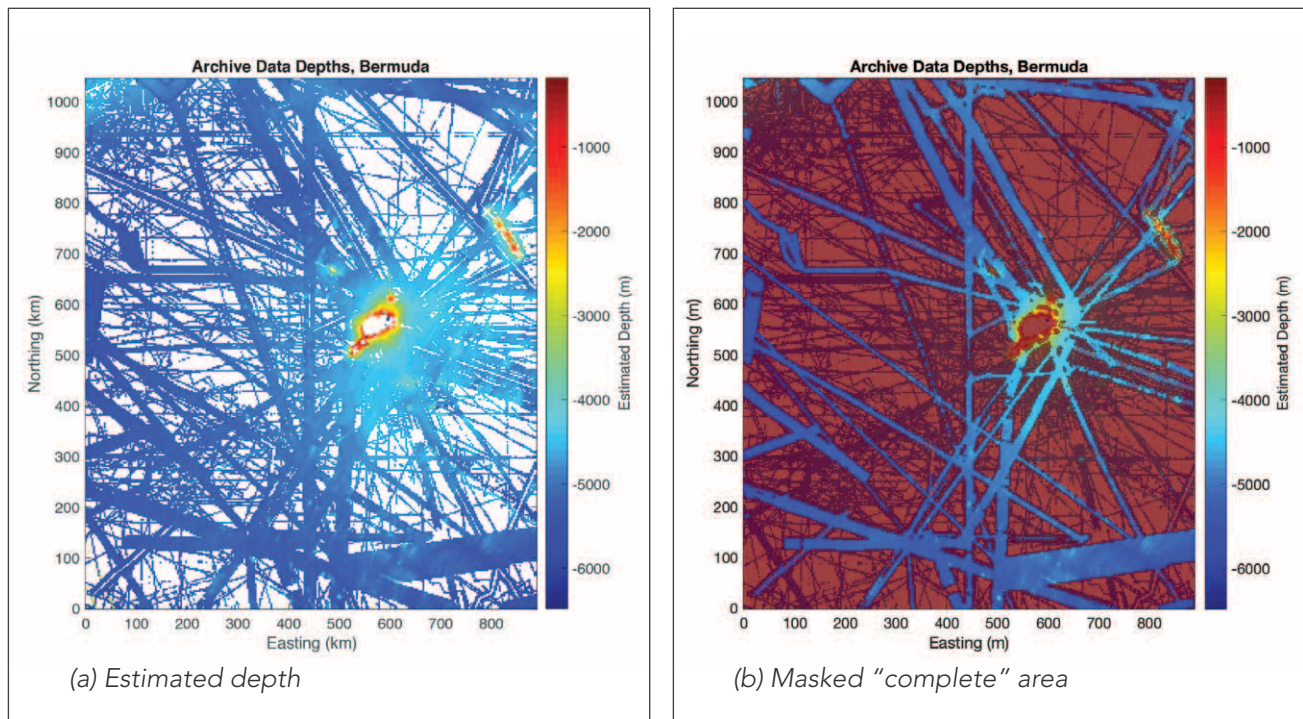

Figure 13-3. Estimated depth (a) and “complete” coverage (b) corresponding to the shaded area in Figure 13-1. Depth is the primary low-resolution CHRT estimate from raw observations at 3,125m cell resolution; areas with semi-transparent red tint are considered “incomplete” given the assumptions of five observations for estimation stability, and 20% noise.



**TASK 14: Multi-detect Processing:** *Develop processing algorithms required to generate multiple detections within a single beam, to appropriately combine their evidence, and to provide qualified detections to the user. We will establish the uncertainty of the measurements determined from the multiple detections, as well as adapt current generation processing algorithms to incorporate the information from multiple detections, and use them to generate the hypotheses being reported while adjusting hypothesis selection to provide more than one “plausible” hypothesis. Pls: Tom Weber and Brian Calder*

Multi-detect offers the promise of improved MBES performance for scenarios where hydrographic targets of interest are not constrained to a single surface (e.g., ship wrecks or submerged structures), where strong targets mask weak ones (e.g., specular reflections from pipelines), and for a variety of other applications where targets of interest are not on the seabed (e.g., fish schools, gas seeps). At least two manufacturers (Kongsberg and Reson) employ a front-end multi-detect capability that is integrated with their normal bottom detection routines, although it appears that the approaches are not yet optimized (Figure 14-1).

Current manufacturer (e.g., Kongsberg) approaches to multi-detect are tied to amplitude (backscatter) threshold, an SNR threshold, and a quality factor. We are exploring additional algorithmic components and have been testing them on recorded water column data (note that water column data does not typically include phase-difference data, with a few notable exceptions, and this has the ultimate effect of making the multi-detects noisier than they otherwise would be). These components are linked in sequence to form a complete multi-detect routine, and the first in the sequence is sidelobe rejection, in which the water column data are stepped through in sequential range increments. At each range increment, the strength of the maximum return across all beams is found, and then any other returns that are lower than this maximum return minus the predicted side-lobe level is suppressed under the assumption that it is possibly a sidelobe. Sidelobe rejection is followed by a simple amplitude threshold, which has the downside of being subjective but the upside of being reportable as a later detection classification tool in follow-up processing schemes. The upper statistical tail of the noise can pass through these first two components but is often readily identifiable as ‘speckle.’ That is, the noise is often distributed randomly throughout the water column data in small clusters

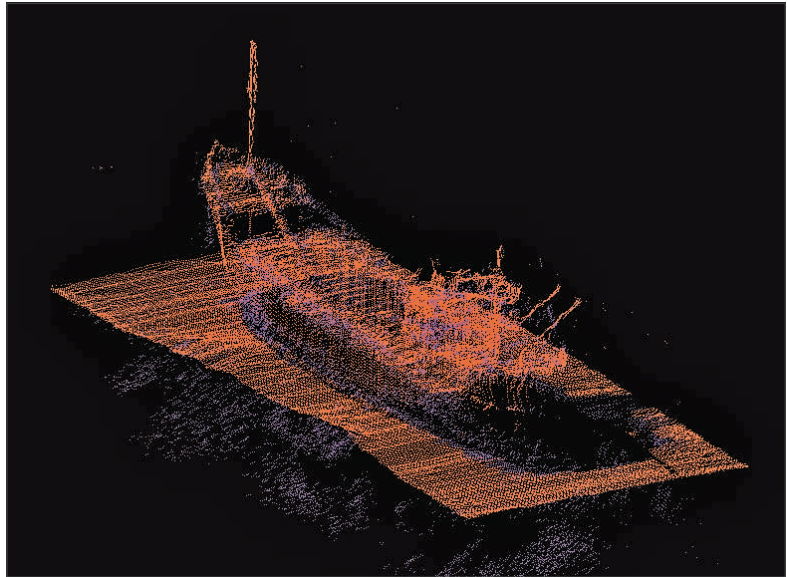

Figure 14-1. Standard seafloor detections (orange) and multi-detects (purple) from an EM2040, data courtesy of J.H.C.

containing 1-2 spatially contiguous samples that are above the amplitude threshold. This manifestation of the noise lends itself to despeckling, a process by which each detection is assessed in terms of its near neighbors, and if the number of near neighbors is small, then the detection is classified as noise and rejected. Finally, the data are clustered into contiguous groups, each of which is associated with a detection.

These multi-detect algorithmic components have been applied to opportunistic data in the past, including the data associated with the shipwreck in Figure 14-1. This year, we have applied these algorithms to a more controlled set of tests using a PVC pipe that is 0.6 m in diameter and slightly more than 4 m long (Figure 14-2). Pipe surveys represent a challenge because they invariably have a high specular reflection that leaks into sidelobes, and because of the underlying substrate which can be preferentially detected rather than the pipe. The PVC pipe used for this work was deployed in the Chase engineering tank. A Reson T50P, mounted on the moveable tank bridge, was used to detect/map the pipe.

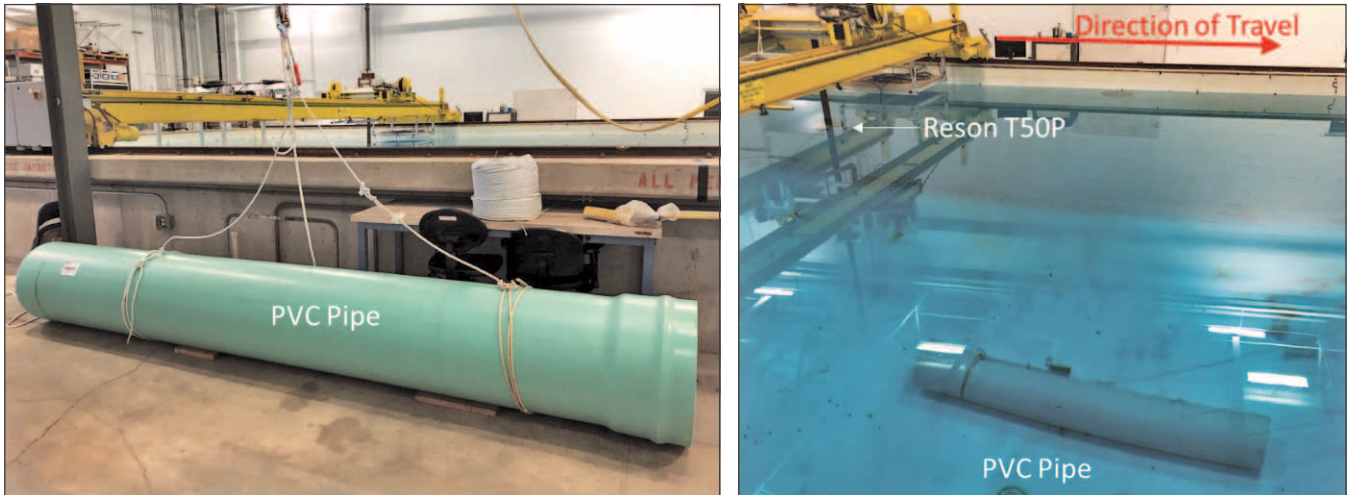

Figure 14-2. PVC pipe deployed in the tank and used for testing multidetect algorithms in the Chase Lab engineering tank.

The tank environment itself represents an extreme environment for a multibeam echo sounder: the hard and (mostly) smooth tank walls and flat water surface create a strong multipath scenario. This can be seen by the detections (both our multi-detects and the Reson standard bottom detects) in Figure 14-3. The vertical tank walls are 'reflected' below the bottom by acoustic paths that leave the T50 projector, experience a specular reflection off the tank wall toward the tank bottom, and then scatter off the tank bottom back toward the projector (or, similarly, scatter off the tank wall and specular reflect off the tank bottom). These reflected/scattered paths are visible in Figure 14-3 as arcs of detections that intersect the tank-bottom corners, slowly growing in range as the receive angle grows further from the direction of the tank-bottom corner. The tank surface also causes an 'image' tank that appears below the tank bottom, visible in Figure 14-3 as walls that appear to extend below the 6 m deep tank. These multipath returns from the tank walls understandably confuse a multibeam echo sounder that is

seeking one bottom detection per beam, and also makes an interesting analog for surveys of sub-surface marine structures including wrecks, pipes, and other subsurface infrastructure.

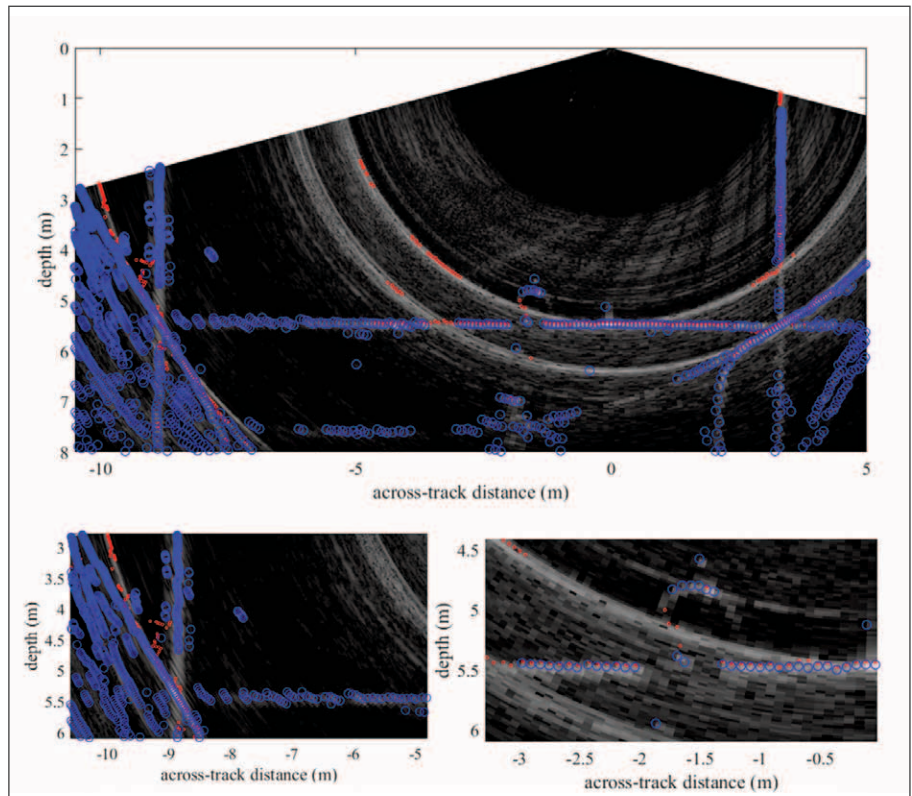

Figure 14-3. A single ping of Reson T50P data from the Chase lab engineering tank. The backscatter intensity is shown in grayscale. Reson standard bottom detections are shown as red dots. Our multidetect algorithm results are shown as blue circles. The pipe is apparent on the tank bottom at an across-track distance of -1.5 m, and in the insert on the lower right.



The PVC pipe itself creates a detection challenge. The impedance contrast between PVC and the tank water is similar to a coarse silt, but the surface of the PVC pipe is extremely smooth even at a frequency of 400 kHz where these measurements were made. The lack of roughness on the pipe severely reduces the scattering levels from the pipe, except close to normal incidence, and likely causes a masking of the tank floor underneath the pipe as some portion of the incident sound wave is specularly reflected away from the tank floor.

The combination of a reverberant tank and a smooth pipe are probably an extreme case (i.e., unnaturally smooth) for a marine scenario, but offer useful insight into MBES detection performance. The Reson standard bottom detections (red dots in Figure 14-3) understandably experiences challenges in this environment. The system:

- mistracks sidelobes, including the sidelobes associated with the strong specular reflection off the tank bottom at a range of ~5.5 m,
- erroneously identifies the reflected/scatter paths (described above) over the tank walls as the chosen detection for certain beams. This latter scenario is most easily observed in the lower left insert of Figure 14-3, where the wall is not detected by the Reson standard bottom detection at all; and for the lower portion of the wall on the right side of the image,
- is occasionally misled by the 'image' of the tank walls appearing below the tank bottom.

The pipe is detected at the specular detection point by the Reson standard bottom detection.

Our multi-detect algorithm appears to be an improvement (note that the Reson multi-detect may be as well, this has not yet been examined). The multi-detect treats the multipath and 'image' tank walls as real targets—as it should—but also does a good job of:

- rejecting areas that are sidelobes or are masked by sidelobes
- detecting the walls and tank bottom, even close to the tank corners where the reverberation provides 'opportunity' for choosing other nearby strong targets
- providing several detections of the pipe, to the extent that it would be possible to consider the tank curvature.

The multi-detect algorithm also appears to get two detections associated with the bottom of the pipe, in the specular direction (see lower right insert in Figure 14-3).

To increase the ability to detect the pipe, two surface treatments were added. A black anti-skid tape was wrapped around the pipes at either end, and several wraps of potwarp (rope) were added (Figure 14-4, left). The pipe was then deployed at sea (Figure 14-4, right), and surveyed with a Reson T50P.

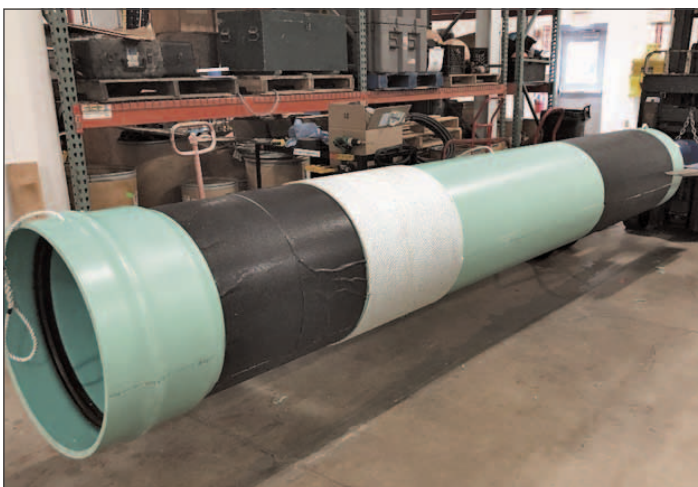

Figure 14-4. The pipe with a 'roughened' surface consisting of antiskid tape and a wrap of potwarp (left image), and the deployment of the pipe at sea using the R/V *Gulf Surveyor*.



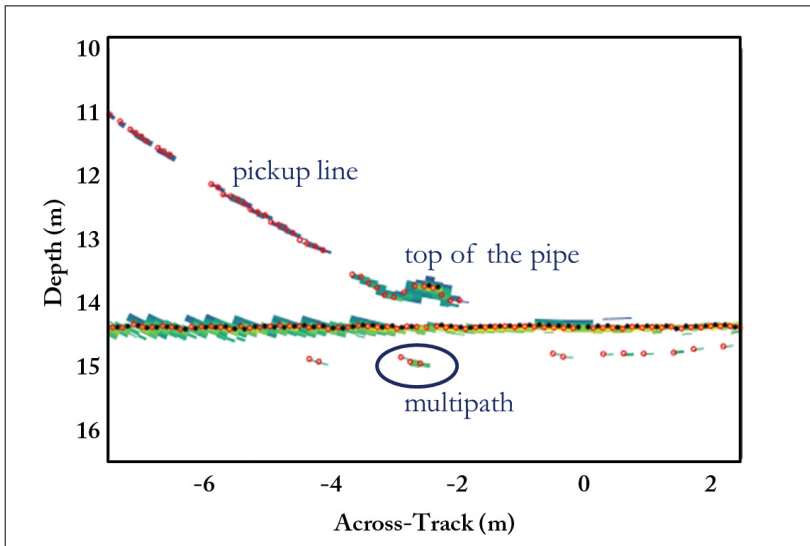

Figure 14-5. A single snapshot showing the result of our multi-detect process including the seafloor the top of the pipe, and the pick-up line used to deploy/recover the pipe.

Figure 14-5 shows the results from our multi-detect process on a single ping of T50P data. In addition to seabed detections in each ping, including under (or through) the partially acoustically transparent pipe, the curvature associated with the top of the pipe can be seen, as can the pick-up line in the water column. This result, processed automatically, suggests there is significant potential for a multi-detect. The multi-detect story becomes more complicated when looking at the pipe data in its entirety (Figure 14-6), however.

The top of the pipe is detected in ~5-10 beams, as the vessel traverses over the top of the pipe, resulting in a qualitatively reasonable-looking map of the shallows portion of the pipe. The backscatter (Figure 14-6, right) shows regions of high backscatter correlated to the areas of pipe in anti-skid tape and potwarp, and low backscatter in between. Interestingly, the bathymetric performance appears roughly equivalent for both the high-backscatter and low-backscatter regions.

The pipe field-tests also suggest a potential fundamental problem for multi-detect, however. The pipe appears to extend significantly past the areas of high backscatter, with decreasing depths (i.e., the ends of the pipe appear to be ‘drooping’ downward). This is a likely manifestation of the pipe appearing ahead of or behind the multibeam, similar to the classic chevron shape of a single target echo in the water column. This effect can also be seen between pings 50-60 for the most negative across-track distances, where the base of the pick-up line can be seen.

The multi-detect solutions give the appearance that the width of the pickup line is almost half-that of

the roughened section of the pipe. This is an issue related to transmit beamwidth, and could be a significant hindrance to interpretation, horizontal positioning, and measuring of targets. The obvious ways around this are either increased transmit beam resolution (or a closer approach in range), or within-beam target angle estimation using the same split-aperture correlator techniques used for across-track phase-detects. The latter is not achievable without a significant system redesign.

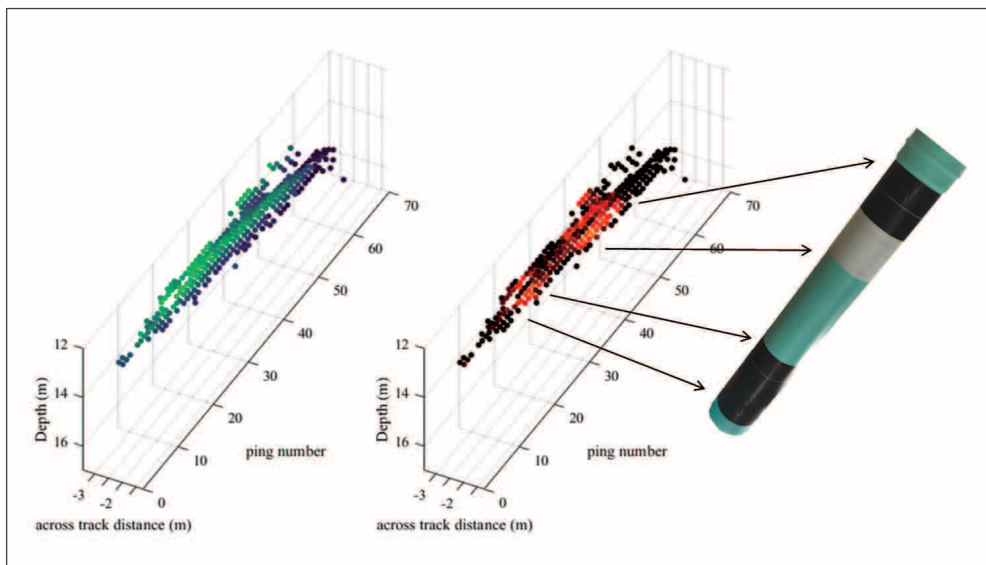

Figure 14-6. Pipe soundings extracted from our multi-detect soundings showing both depth (left) and backscatter (right). Hotter colors are shallower (left) and stronger backscatter (right).

**TASK 15: Data Quality and Survey Validation Tools:** *The development of tools and methods to assess the quality of data during early- and mid-stage processing, primarily to establish a baseline quality standard, assessing the degree to which the data meet the requirements. Additionally, we will develop tools and methods to actively manage the data processing procedure, identifying problem areas in the data, ensuring that objects are appropriately identified and addressed, and keeping track of those objects to ensure that all are addressed before the survey is closed; provide a ‘pack and go’ option to ensure that the data is complete before the survey is readied for delivery; aggregate information, provide a system-monitoring dashboard, and derive management data. Finally, we will explore the development of tools and methods to support mid-stage office-based data processing: tracking objects, assisting with sounding selection, and correlation of hydrographer notes and chart objects. PI: **Brian Calder***

**JHC Participants:** Giuseppe Masetti and Christos Kastrisios

**Other Participants:** Tyanne Faulks (NOAA PHB); Julia Wallace (NOAA AHB); Damian Manda, Glen Rice, Jack Riley, Barry Gallagher, Chen Zhang, Eric Younkin, and John Doroba (NOAA HSTB); Gretchen Imahori, Joshua Witmer (NOAA RSD), Kim Picard, Aero Lepplastrier, Justy Siwabessy, and Georgina Falster (Geoscience Australia); Mark Paton (QPS); Stuart MacGillvray (Teledyne CARIS); Jeff Adams (Leidos).

The volume of modern survey data makes it difficult to address each observation for correctness or quality individually. Even products from surveys can be difficult to assess en masse (for example, finding a single outlier in a multi-million node grid). More importantly, it can be difficult, or at least very time consuming, to confirm that all of the requirements from a given survey specification are being met within a particular dataset (for example, does every S-57 attributed object have a corresponding bathymetric expression?). These types of problems, however, often have the potential to be automated, since they can consist of essentially simple rules applied in the same manner each time to large amounts of data. Recent field experience using the tools described below show that this process can lead to significant workflow efficiency improvements.

Not all rules or best practices are simple to translate into computable form, however. The rules and best practices used in the field are developed over many years by hydrographic offices and other mapping agencies, and the thousands of experience-based rules that are reflected in survey specifications are often subject to human interpretation. They can also be, sometimes deliberately, vague. This can make them hard to interpret unambiguously enough to be transformed into code, but this is essential if they are to be applied consistently at scale.

The projects in this task, therefore, are considering how to translate these rules into computable form, and how to prompt careful re-formulation of the rules where required in order to obtain a computable interpretation. This is not to suggest that all rules

can be so transformed: some will always require the “judgment of an expert hydrographer.” However even identifying this subset is, in itself, a useful endeavor since it informs the potential for automation: the more rules require human intervention, the less automation is possible. Understanding the extent to which this is the case will also help to inform decisions about the future structure of survey workflows.

### QC Tools (HydrOffice)

Since 2015, the Center has collaborated with NOAA HSTB personnel to develop a suite of analysis tools designed specifically to address quality control of problems discovered in the NOAA hydrographic workflow. Built within the HydrOffice tool-support framework (<https://www.hydrooffice.org>), the resulting QC Tools were released in June 2016, and have since been enthusiastically adopted by NOAA field units and processing branches. Indeed, yearly updates and edits to NOAA’s Hydrographic Survey Specifications and Deliverables are now made with an eye toward automation, anticipating implementation via QC Tools. In the current reporting period, Giuseppe Masetti, Tyanne Faulkes (NOAA PHB), and Brian Calder have continued, in collaboration with Julia Wallace (NOAA AHB) and NOAA HSTB personnel, to develop the toolset. The application, which aggregates a number of tools within a single GUI is available through NOAA Pydro (which delivers software to the NOAA hydrographic units) and through the HydrOffice website for non-NOAA users. A number of mapping agencies, NOAA contractors, and other professionals have adopted some of these tools as part of their processing workflow.

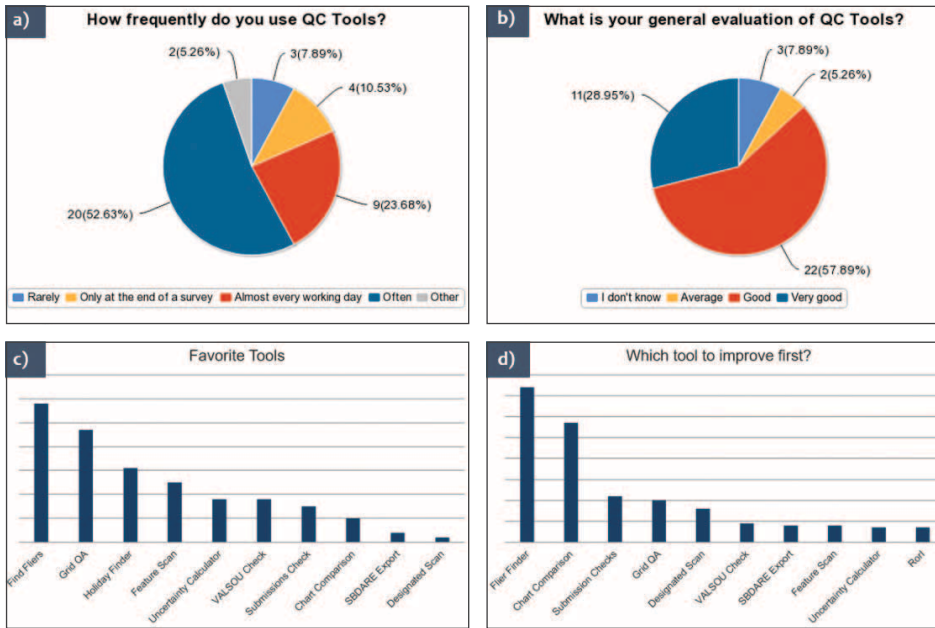

Figure 15-1. Results of the user-survey. The upper boxes (a, b) capture the frequency and the evaluation of QC Tools for the survey respondents. Box c shows the popularity among the sub-tools in QC Tools. Box d provides hints about the two sub-tools ('Flier Finder' and 'Chart Comparison') that users suggest development further.

QC Tools is in active use in the field, which is a valuable source of feedback and suggestions. Before the beginning of the 2019 field season, a customer satisfaction survey was performed among NOAA Office of Coast Survey users (Figure 15-1). Of 39 NOAA respondents, about 75% use QC Tools almost every single working day (Figure 15-1a). This provides evidence that the application is judged valuable to the QC Tools community. The survey also provided useful hints on where to put current and future improvement efforts (Figure 15-1d).

The recent introduction in the OCS hydrographic workflow of variable resolution surfaces has removed the fixed resolution per depth range structure in use for single resolution grids. This made calculation of the flier height

thresholding mechanism in the Find Flier sub-tools more difficult. Masetti and Faulkes are currently working on an algorithm to calculate a localized flier height (per-node) using grid-derived proxies including the median depth, roughness, and depth range variability (Figure 15-2). The resulting new Anomaly Detector sub-tool is currently only experimental, but some preliminary tests show that the new approach should provide a more robust solution (i.e., with reduced false and missed fliers) than Flier Finder when analyzing variable resolution grids.

In the current reporting period, QC Tools has also improved existing sub-tools to enhance the detection of anomalous data by the "Find Fliers" algorithm (Figure 15-3) and improve the validation of elevation-related feature attributes in the Feature Scan algorithm.

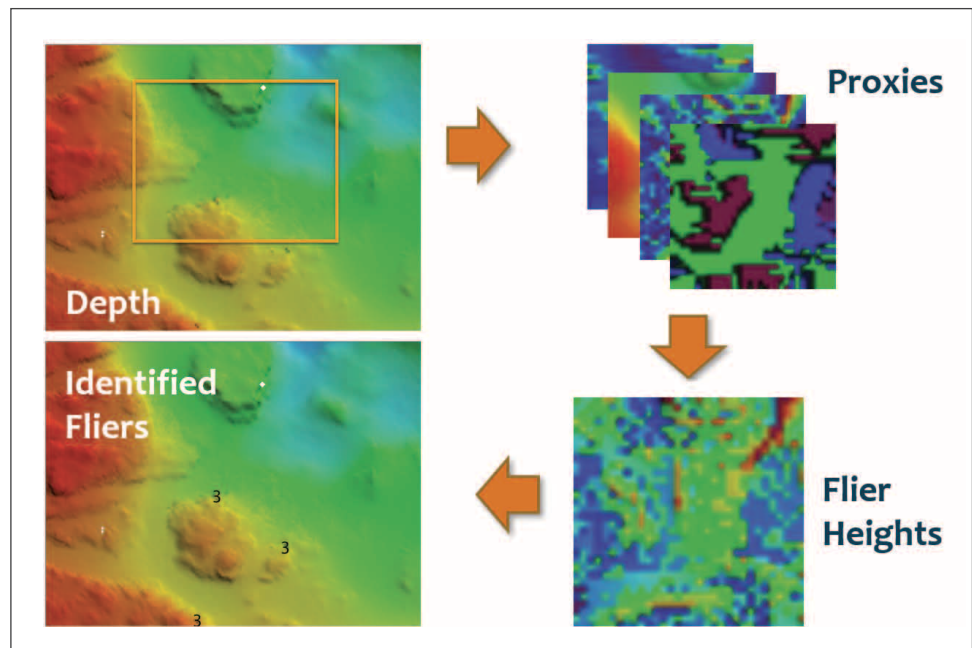

Figure 15-2. Structure of the Anomaly Detector algorithm. This calculates localized flier heights using grid-derived proxies, potentially resulting in fewer false positives and missed fliers.



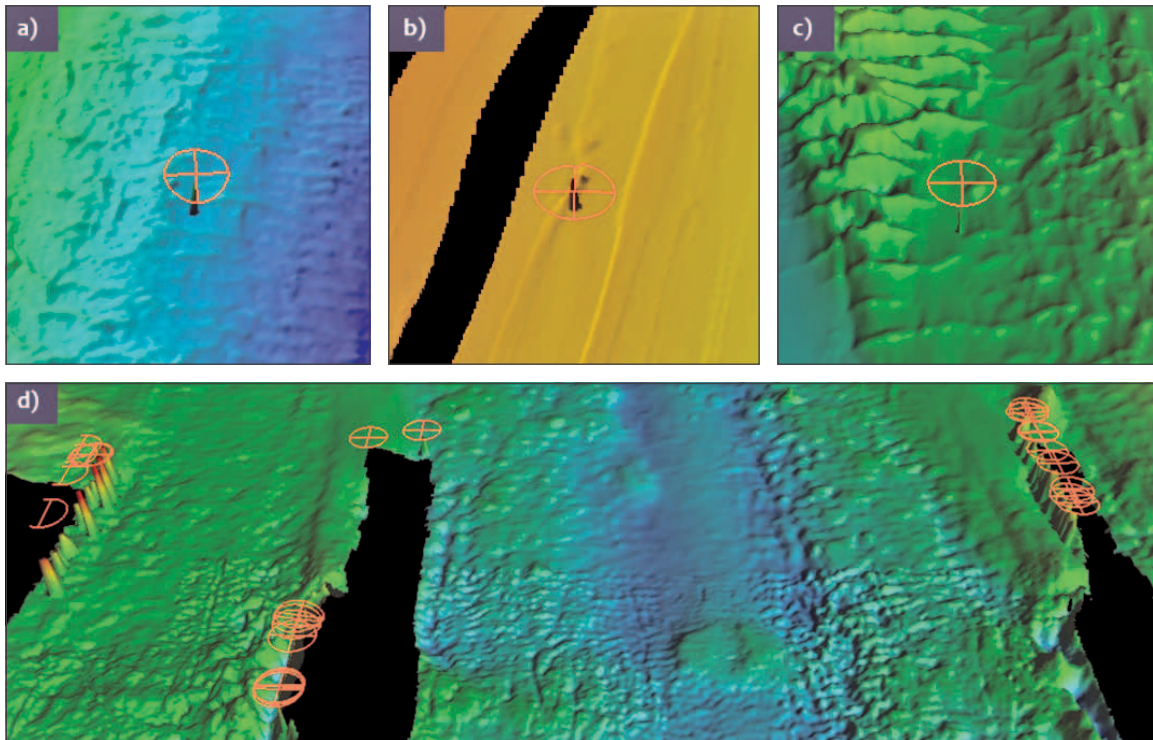

Figure 15-3. Improvements in the Find Fliers sub-algorithm. The upper panes ('a', 'b', and 'c') show examples of identified fliers using the 'traditional' set of bathymetric anomaly detection algorithms. Recently adopted technologies in the NOAA OCS workflow have generated a new type of fliers that required the introduction of dedicated 'noisy edges' algorithm (examples of detected fliers are shown in pane 'd').

An intentional design feature of QC Tools is that the implementation is particularly flexible, allowing for the accommodation of new tools and recurring changes to policy and best practice. The algorithms are carefully separated into libraries, for which the GUI is simply an interface. This allows the application to be tailored for non-NOAA users (who do not have Pydro or NOAA-specific S-57 attribute tables) and distributed through the HydrOffice website, as well as through the NOAA-specific Pydro distribution. The library-based design has also allowed the tools to be called non-interactively from an automation tool ("Charlene") built by Eric Younkin (NOAA HSTB), to manage overnight processing of data collected by the fleet, as well as the creation of task-specific scripts that help NOAA OCS hydrographic branches to automate a variety of checks.

The QC Tools application is supported by publicly available documentation as well as NOAA-generated instructional videos, available through the HydrOffice website, or directly via YouTube. The QC Tools development team was invited by Geoscience Australia to provide training on the application (and an overview

of other HydrOffice tools) during the week-long AusSeabed–NOAA Office of Coast Survey–CCOM/JHC Workshop, "Effective Seabed Mapping Workflow."

### CA Tools (HydrOffice)

Timely and accurate identification of change detection for areas depicted on nautical charts constitutes a key task for marine cartographic agencies in supporting maritime safety. This task is usually approached through manual or semi-automated processes, based on best practices developed over the years that require a substantial level of human commitment (i.e., to visually compare the chart with the newly collected data or to analyze the result of intermediate products). In the current reporting period, Giuseppe Masetti and Christos Kastrisios, in collaboration with Tyanne Faulkes (NOAA PHB), have continued the development of CA Tools, an application begun in 2018 aiming to act as a container of tools to automate this chart-adequacy task by comparing current Electronic Navigational Charts (ENCs) with newly acquired survey data sets.

During the second half of 2018, a first release of a Chart Comparison tool was developed, then made available to the NOAA OCS field units, on an experimental basis, through the Pydro framework. Chart Comparison implements an algorithm that aims to largely automate the change identification process as well as to reduce its subjective component. Through the selective derivation of a set of depth points from a nautical chart, a triangulated irregular network is created to apply a preliminary tilted-triangle test to all the input survey soundings (Figure 15-4). Given the complexity of a modern nautical chart, a set of feature-specific, point-in-polygon tests are then required. As output, the algorithm provides danger-to-navigation candidates, chart discrepancies, and a subset of features that require human evaluation. During the 2018 field season, the algorithm was successfully tested with real-world electronic navigational charts and survey datasets (Figure 15-5).

Based on field feedback, several improvements have been introduced to the original algorithm that was published in the *International Journal of Geo-Information* (DOI: 10.3390/ijgi7100392) as "Automated Identification of Discrepancies Between Nautical Charts and Survey Soundings." In particular, a field feature request triggered the creation of a tool for soundings selection from bathymetric grids that currently implements both a "moving-window" and a "point-additive" algorithm (Figure 15-6).

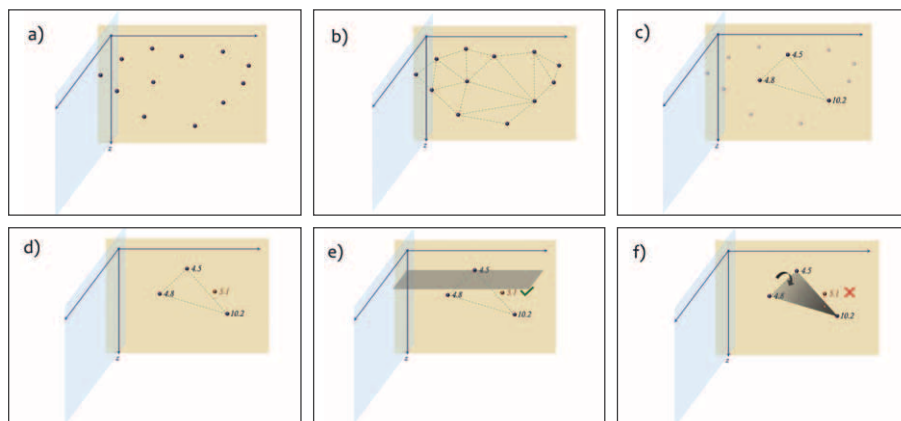

Figure 15-4. Implementation of the Tilted Triangle Test in Chart Comparison. In pane 'a', a few nodes are represented as they were collected from a nautical chart. Pane 'b' shows the resulting triangulated irregular network from the collected nodes. Pane 'c' focuses on a specific triangle with the nodes from the nautical chart (in green) as vertices. Pane 'd' shows, in orange, an example of newly collected survey sounding. Pane 'e' demonstrates that the traditional Triangle Test does not capture the chart discrepancy highlighted by the survey sounding, while the Tilted Triangle Test capture it (pane 'f').

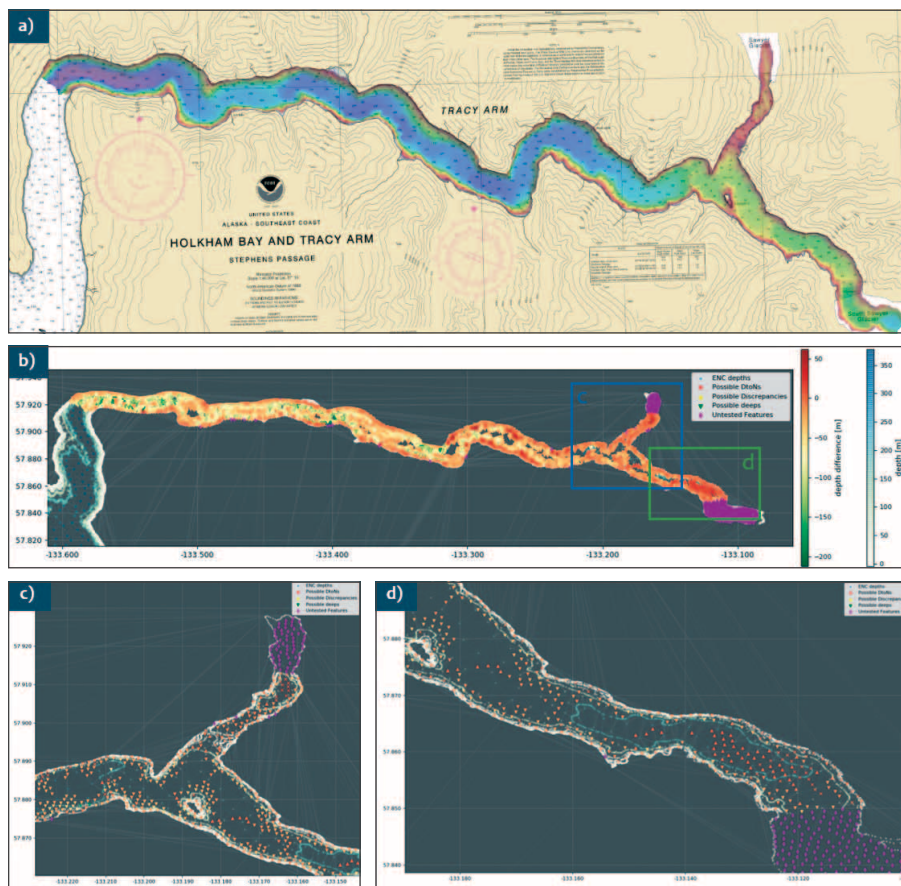

Figure 15-5. Field example of the Chart Comparison tool. Pane a: bathymetric model generated using the data collected by from NOAA survey H13071. NOAA raster nautical chart (Holkham Bay and Tracy Arm) is shown in the background. Pane b shows the results of the Chart Comparison tool using survey H13006's soundings compared to the US4AK35M ENC. Axes in geographical WGS84 coordinates. The areas in panes c and d were selected to illustrate the large detected chart discrepancies.

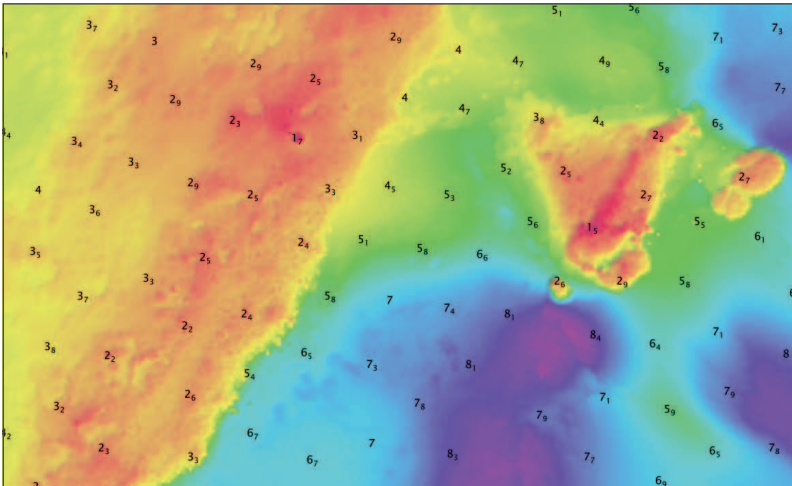

Figure 15-6. Example of output soundings created using the “point-additive” algorithm provided by the Sounding Selection tool recently introduced in CA Tools. The algorithm can take as parameter a user-defined search radius (in meters) or can automatically retrieve the compilation scale from an ENC (if provided).

The addition of the Sounding Selection tool both makes the workflow repeatable for users using different commercial processing software and increases the control on the survey selected soundings that are one of the two inputs of the Chart Comparison tool. An updated flowchart that combines the Sounding Selection and the Chart Comparison tools is provided in Figure 15-7; an example of the output obtained is provided in Figure 15-8.

### Open Navigation Surface Working Group (BAG Data Transfer Format)

A key component in assessment of data quality and workflow assurance is ensuring that the data has a safe place to go, and that the quality metrics attributed are not lost as part of the processing effort. Since its inception in 2003, the Bathymetric Attributed Grid (BAG) data transfer format has provided a standard method for representation of fixed (and since 2015, variable) resolution gridded bathymetric data, along with metadata and an uncertainty estimate at the same resolution as the bathymetry. The Open Navigation Surface Working Group project, which maintains the BAG specification and access library, is hosted by the Center.

In the current reporting period, the Open Navigation Surface library (<http://www.opennavsurf.org>) has benefited from re-organization of the library to remove larger sub-projects into sub-repositories, which necessitated transition to GitHub as a repository hosting service. The project also adopted a BSD three-term license, accepted a proposal from NOAA for an auxiliary metadata layer to support their composite BAG structure required for the National Bathymetric Database, and updated the project website to support better visibility of the participants in the project.

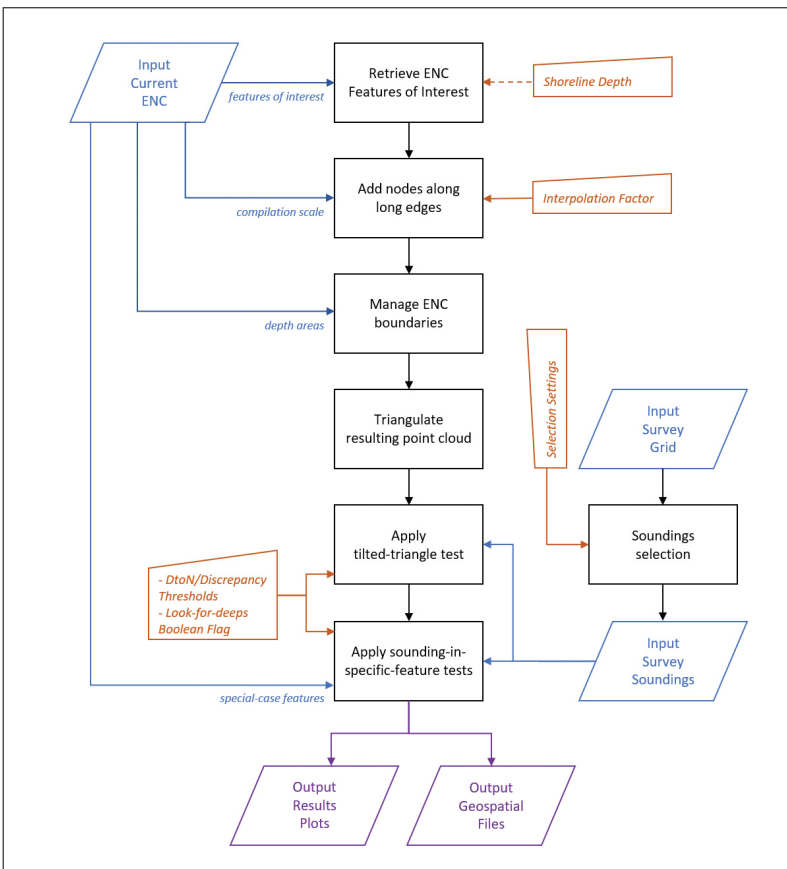

Figure 15-7. Flowchart for CA Tools. The flowchart shows, in black, the main steps of the two combined tools (i.e., Sounding Selection and Chart Comparison). The inputs are represented in blue, the user parameters in orange (with a dashed connector when optional), and the outputs in purple.



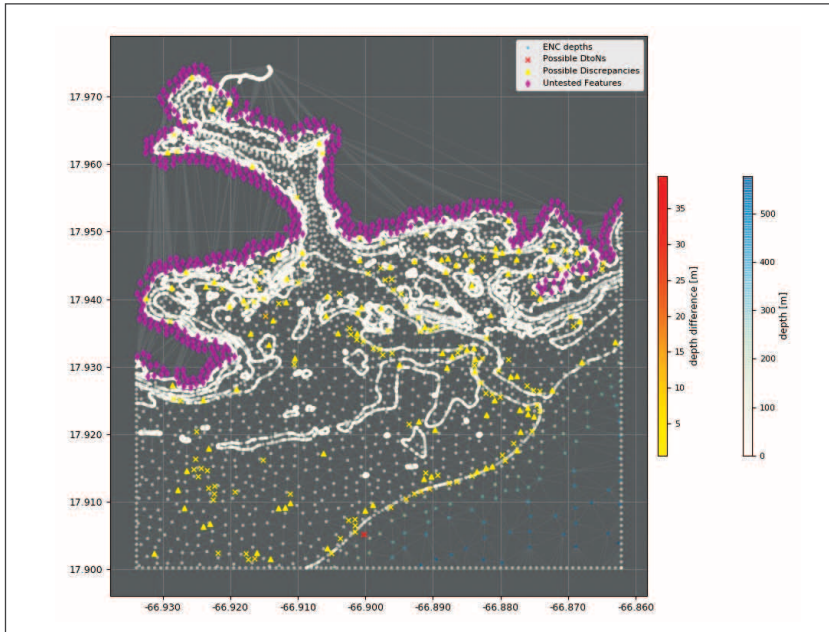

Figure 15-8. Results from the combined workflow obtained using the Soundings Selection and the Chart Comparison tools. The survey's selected soundings, obtained from the survey PR-1401's bathymetric grid, are compared to the US5PR63M ENC. Axes in geographical WGS84 coordinates.

Based on the outcomes of the ONSWG meeting in October 2018, Giuseppe Masetti established a GitHub organization (<https://github.com/OpenNavigationSurface>) with a main "BAG" repository (i.e.,

the core library) and a "bagViewer" sub-repository which contains an example QT5/OpenGL application to display BAG files (Figure 15-9). Masetti has also worked on the prototype for a new website for the project (Figure 15-10) with the goals of increasing discoverability and simplifying the process for publication of new content. The new website will be presented to the working group at the next meeting (during Canadian Hydrographic Conference 2020).

During the ONSWG meeting in March 2019, a large re-organization of the BAG code base was proposed. One of the discussed improvements was the adoption of continuous integration development to ensure the library continues to build smoothly after modifications. Giuseppe Masetti, in collaboration with Glen Rice (NOAA HSTB), implemented the required changes to adopt the continuous integration under Linux (i.e., Ubuntu) and Mac using Travis-CI services (free for open-source projects). An experimental continu-

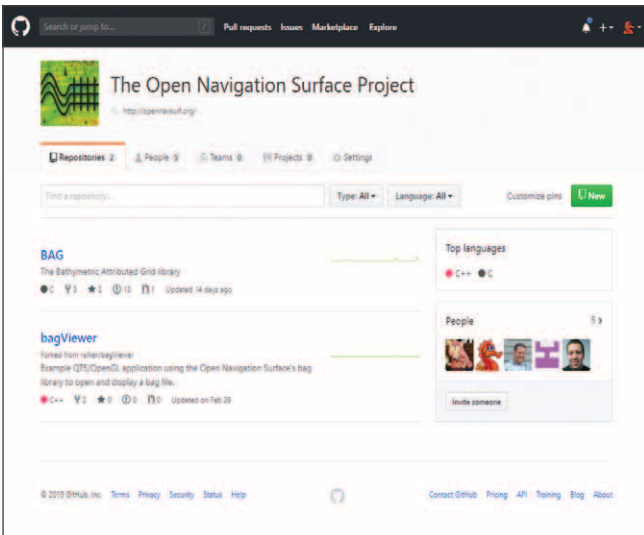

Figure 15-9. The landing page of the Open Navigation Surface Project GitHub organization. Moving the project to GitHub in place of the old (now deprecated) BitBucket repository aligns the BAG library with most popular open-source projects. It may also help to improve the visibility of the overall ONSWG project.

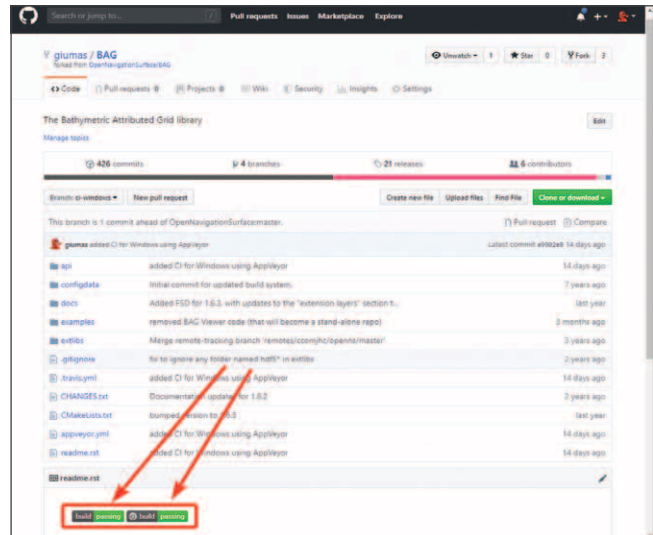

Figure 15-10. The new proposed website for the ONSWG based on GitHub Pages.

ous integration was also implemented for Windows using AppVeyor (Figure 15-11). A test framework for regression testing of the library has also been selected, using Catch2, and Masetti has initiated a new collaboration with Glen Rice (NOAA HSTB), Mark Paton (QPS), Stuart MacGillivray (Teledyne CARIS), and Jeff Adams (Leidos) to evaluate different approaches to storing variable resolution refinements in the HDF5 structure used for BAG files.

A further consequence of the 2019-03 meeting was the understanding that the current library API needs redevelopment to put it on a stable basis for the future. Consequently, development of a prototype replacement API for the library, sponsored by NOAA, has continued throughout 2019, and is expected to be considered by the working group at the Canadian Hydrographic Conference in 2020-02.



Figure 15-11. The adoption of continuous integration across the three major operative systems (i.e., Windows, Linux, and Mac) facilitates the maintenance of cross-platform library requirements. The red arrows show the continuous integration badges indicating the current status of the project (green when passing) and providing a link to the corresponding services (Travis-CI and AppVeyor).

**TASK 16: Phase Measuring Bathymetric Sonar Processing:** Continue engineering, evaluation, and post-processing efforts for PMBS systems. Continue development of new signal processing algorithms that provide additional robustness against multipath returns when measuring the direction of arrival of incoming signals.

**PI: Val Schmidt**

As discussed in Task 2, our research efforts with respect to Phase Measuring Bathymetric Sonars have indicated continued issues and limitations with respect to hydrographic quality data and advantage over other methods, and thus the effort on PMBS has been de-emphasized within the context of the grant. Nonetheless, Schmidt continues to keep abreast of progress with the systems and continues to work with manufacturers and software developers to increase their capability and suitability for hydrographic applications.

**Task 17: Automatic Data Processing for Topo-Bathymetric Lidar Systems:** Investigate automated processing tools for topo-bathymetric lidar data, with the aim of providing output products that include uncertainty, metrics for quality assurance, and a strong visual feedback mechanism (again coordinated with our visualization team) to support user manipulation of the data. This process will involve establishing an uncertainty model for topo-bathy lidar, adapting current generation processing tools, and exploring the use of waveform shape, reflectance, and other features as aids to processing. **PIs: Brian Calder and Firat Eren**

**JHC Participants:** Kim Lowell

**Other Collaborators:** Chris Parrish, Jaehoon Jung, and Nick Forfinski-Sarkozi (Oregon State University/NOAA RSD); Stephen White, Gretchen Imahori, Mike Aslaksen, and Jamie Kum (NOAA RSD)

New-generation topographic-bathymetric (“topobathy”) lidar systems have the potential to radically change the way that lidar data is used for hydrographic mapping. Specifically, they generate significantly more dense data, albeit generally in shallower water depths, resulting in improved data and product resolution, better compatibility with modern data processing methods, and the potential to fill in detail in the shallow regions where acoustic systems are least efficient.

NOAA’s National Geodetic Survey, Remote Sensing Division (RSD) routinely use topobathy lidar data in updating the National Shoreline, and they are also useful for regional sediment movement studies, flood risk estimates, and emergency management. Routine ingestion of topobathy data into the hydrographic charting pipeline is, however, problematic. In addition to large volumes of data being generated, which makes processing time-consuming and many tools ineffective, the topobathy data lacks a robust total propagated uncertainty model that accounts for the aircraft trajectory and laser beam ranging uncertainties as well as the behavior of the laser beam in response to waves and the water column.

In conjunction with RSD and colleagues at Oregon State University (OSU), the Center is developing tools to understand and predict the sensor uncertainty of typical topobathy lidar systems, and adaptations of current-generation data processing tools to the lidar data processing problem.

**Total Propagated Uncertainty Model for Topobathy Lidar Systems**

A Total Propagated Uncertainty (TPU) model for lidar systems can be broken into two components (Figure 17-1): the sub-aerial vector from the lidar to the water surface, and the sub-aqueous vector from the water surface to the seafloor. This decomposition reflects the fact that the subaerial component is well modeled using standard geomatics techniques (analytical propagation of variances), whereas the subaqueous portion is more challenging to model analytically, and better suited to a Monte Carlo ray tracing approach. The subaerial uncertainty model uses the trajectory uncertainties, along with estimated ranging and scan angle uncertainties, and a laser geolocation equation to propagate the measurement uncertainties to laser point coordinate uncertainties as the pulse is incident on the water surface.

In previous reporting periods, a TPU model for Reigl VQ-880-G lidars, as flown by RSD among others, was developed and implemented in the cBLUE (Comprehensive Bathymetric Lidar Uncertainty Estimator) tool, Figure 17-2. At a high level, the cBLUE software is designed to take a number of input data sets and parameters, which are readily available in existing topographic-bathymetric processing workflows, compute per-pulse uncertainty estimates for seafloor points, and output uncertainty metadata, summary statistics, and point clouds with per-point uncertainty attributes, which can be used in generating total propagated uncertainty surfaces. The first fully-operational version of cBLUE was delivered to NOAA/NGS in January 2018, and additional lidar training, including cBLUE training was conducted by Christopher Parrish (Oregon State University) at NOAA RSD on 2019-12-10/11.

The software, including source code, is hosted as a GitHub code repository (<https://noaa-rsd.github.io/cBLUE.github.io>), so that at any time, a main (or “base”) branch contains the latest fully-tested version of the software, while development branches are used for research and testing. After discussions among the Center, OSU, and RSD, it was concluded that the appropriate technology transfer choice for cBLUE was to make the project open source, specifically so that instrument manufacturers, as well as RSD contractors, would be able to benefit from the research;

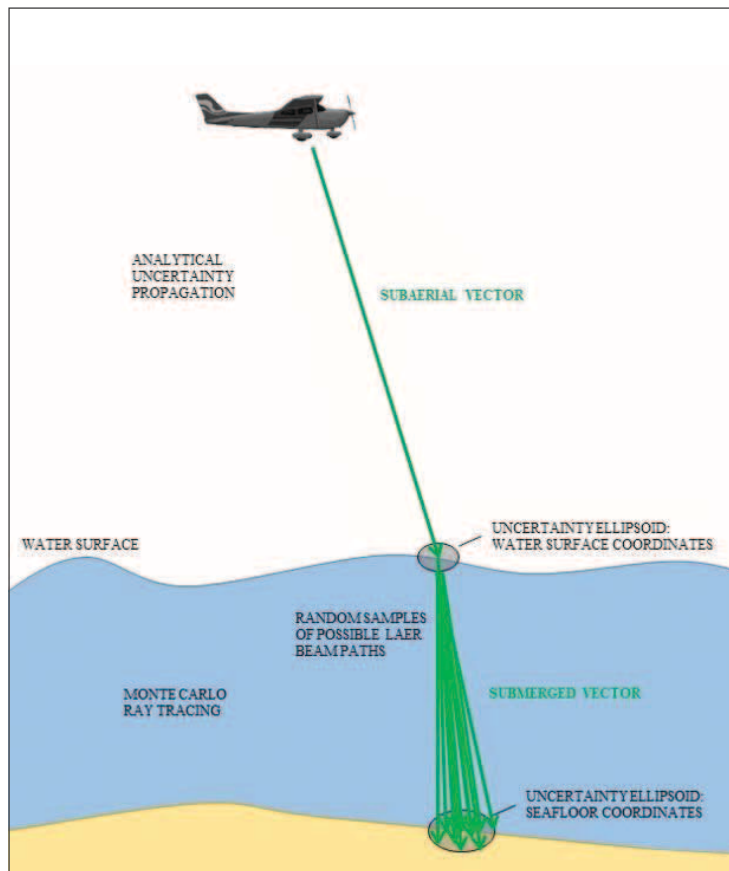

Figure 17-1. Decomposition of the two main uncertainty factors for topobathy lidar systems: the sub-aerial (lidar to water) and sub-aqueous (water to seafloor) components.



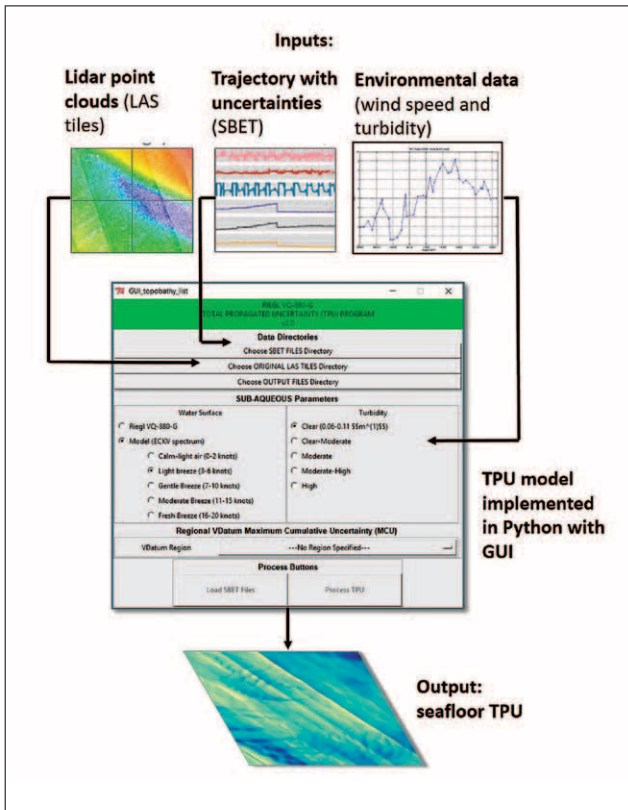

Figure 17-2. Overview of cBLUE software, including inputs and output.

an additional goal is standardization of the algorithm. The code was therefore released under the GNU Lesser General Public License (v. 2.1). Since then, the tool has been reported as being in use by a number of contractors and vendors, and Reigl are implementing a version of a TPU model in their next generation firmware and software for the system. Meanwhile, at the 2019 Annual Coastal Mapping Workshop of the Joint Airborne Lidar Bathymetry Technical Center of Expertise (JALBTCX), the project team led a discussion session on bathymetric lidar TPU. The session focused on documenting hydrographic surveying/nautical charting requirements for bathymetric lidar TPU, methods for benchmarking/validation of TPU software, and support for TPU by the American Society for Photogrammetry and Remote Sensing (ASPRS) LAS Working Group. A major recommendation from the session was for cBLUE to be recognized as the standard against which other bathymetric lidar TPU software can be tested.

In the current reporting period, significant development of the model has been accomplished. In addition to much effort in documentation of the code and tool, the project has been updated to use Python 3, been made significantly more extensible and maintainable through better object encapsulation, implemented multiprocessing for better performance, and has added support for LAS file "ExtraBytes," which are used to store uncertainty information in the LAS file, rather than writing it as a separate file that needs to be merged with LAS information for processing. In addition, the core TPU geo-location model has been extended, the system is being extended for new sensors, and the project team are consciously developing outreach and best practice strategies to ease adoption of the new technology into processing and operational workflows. Sadly, however, we have also had a staff transition, as Firat Eren has moved to a new position back in his home country. The Center is actively seeking a replacement.

During initial development, a simpler geo-location equation was developed for the lidar sensor model which did not include smaller factors that were expected to be well known. This simplified the development, and generated TPU estimates that were plausible, and sufficient for pathfinder development and implementation. In some systems, however, such features may be more important, and extensions of cBLUE to other sensors requires that these effects are now more rigorously considered. Consequently, significant effort has been expended in expanding the geo-location equation to include

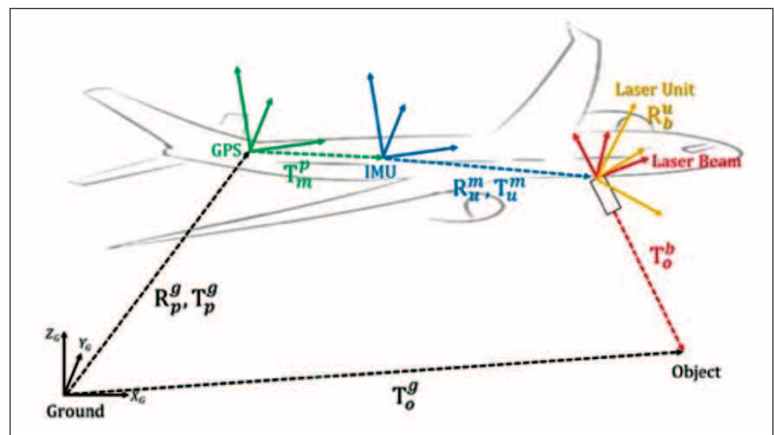

Figure 17-3. Improved geo-location model for cBLUE, which includes boresight calibration misalignments. These are typically small but can be significant in some cases.

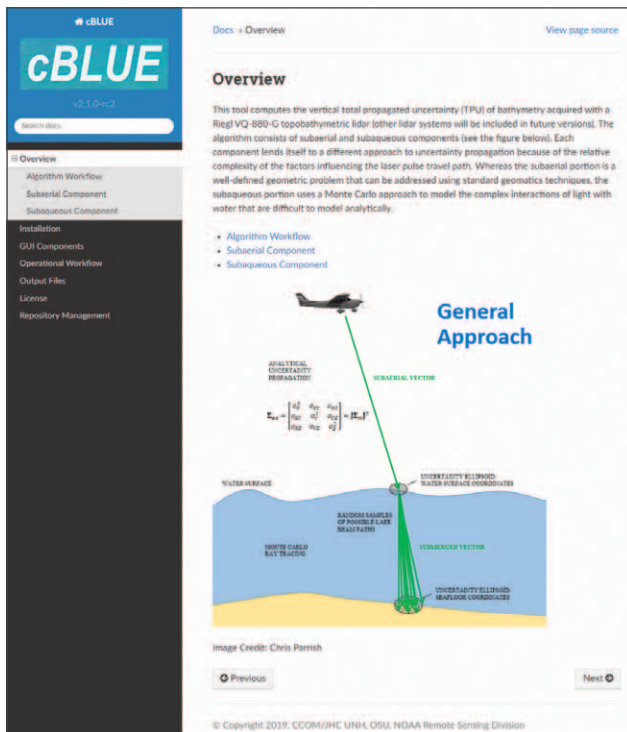

Figure 17-4. Documentation of the cBLUE tool in the GitHub repository. Much effort has been placed in carefully documenting the tool itself, and its operational use.

boresight parameter uncertainty (Figure 17-3), which allows the lidar equivalent of a patch-test uncertainty to be included in the computation.

The current cBLUE model was designed to be generic but was initially customized to the Reigl system most commonly used in RSD’s workflow. With the basic model more mature, effort has turned towards supporting other systems, starting with the Teledyne Optech CZMIL system currently being flown by JALBTCX and the Naval Oceanographic Office (this was requested by both JALBTCX and NOAA RSD). This has included developing relationships with operators and vendors so that critical information such as beam divergence, pointing angle uncertainty, and ranging uncertainty is available for inclusion in the model, and in re-building the reference tables for the sub-aqueous portion of the model, which rely on a Monte Carlo simulation approach.

This latter effort has been particularly important since, with the transition of Eren, transfer of this capability was essential. This has been supported by significant documentation of the code and operational procedures, which are available in the GitHub repository for the project (Figure 17-4).

The subaerial TPU component for CZMIL is based on the CZMIL laser geolocation equation developed by CDR Michael Gonsalves (NOAA), as part of his dissertation research (Gonsalves, 2010). To address the subaqueous component, OSU graduate student Selina Lambert has been generating a look-up table of polynomial coefficients for the fit of vertical uncertainty to depth (for tabulated pairs of wind speed and diffuse attenuation coefficient values) for the CZMIL Nova utilizing the Monte Carlo approach embedded in cBLUE. Since the CZMIL Nova is capable of mapping to greater depths than the Riegl VQ-880-G, greater depth ranges needed to be considered in the simulations, which required a detailed investigation of the algorithm’s implementation, and specifically, for each maximum depth, asking: what is the corresponding maximum diffuse attenuation coefficient,  $K_d$  allowed as a function of the number of simulated scattering layers? The results (Figure 17-5) show that the shallow channel maximum depth is  $2/K_d$  (bottom reflectivity > 15%), and the deep channel maximum depth is  $4.2/K_d$  (bottom reflectivity > 15%). The deep channel limit function lines up with the limits on a

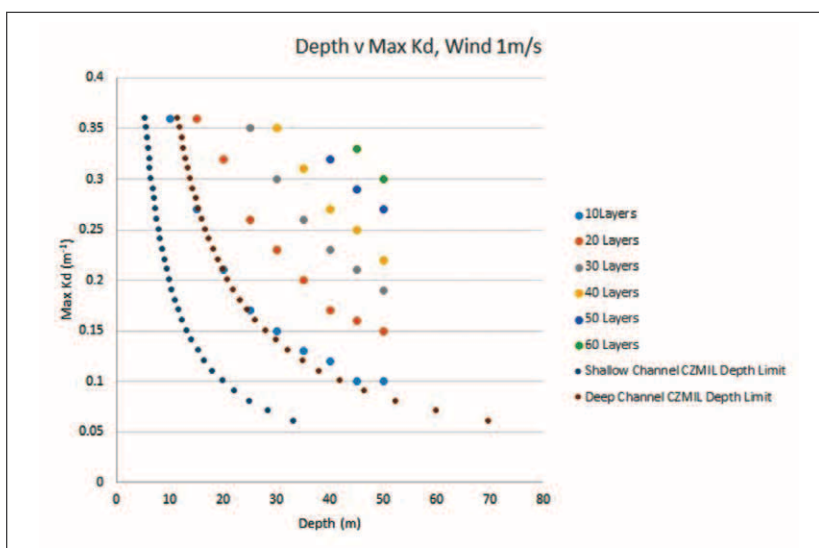

Figure 17-5. The maximum  $K_d$  that can be used to compute uncertainty at a depth, by number of scattering layers for a wind speed of 1m/s. The deep and shallow channel depth limits described by the specification sheet are also plotted. The deep channel limit is very closely aligned to the simulation limits with 10 layers.

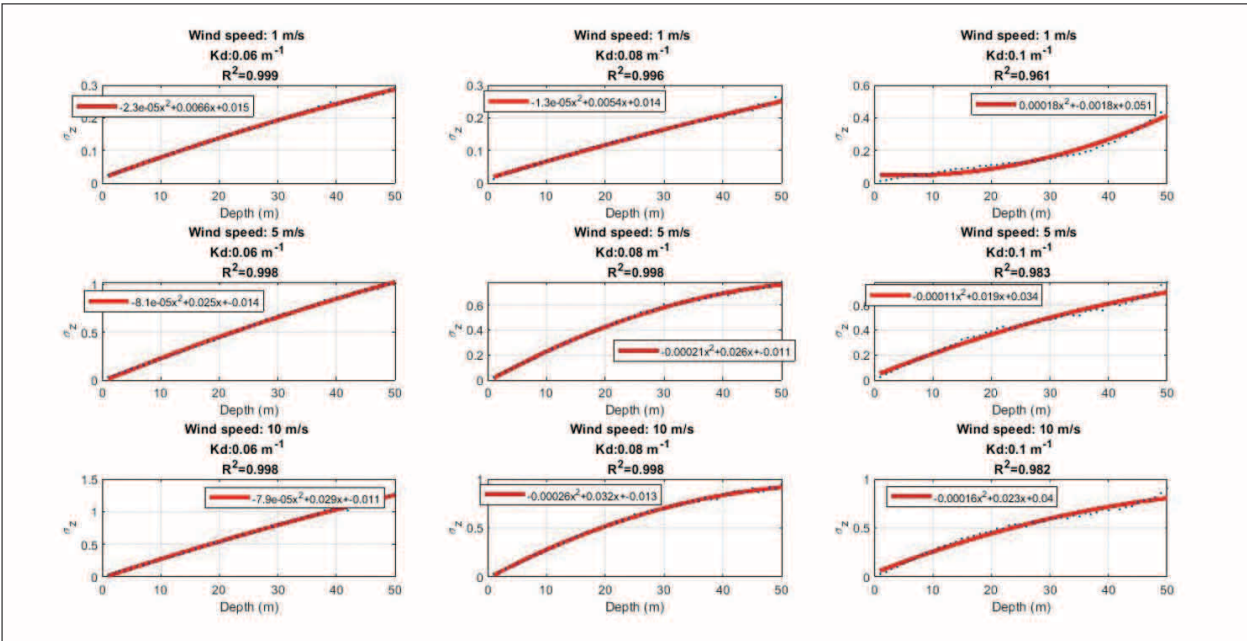

Figure 17-6. A sampling of the simulation results for CZMIL and their polynomial fit: depth vs.  $\sigma_z$  for wind speeds of 1, 5, and 10 m/s and Kd of 0.06, 0.08, 0.1 m<sup>-1</sup>.

simulation with just 10 layers. Using this setting, the CZMIL lookup tables were then computed; an example is shown in Figure 17-6.

Given these results, a planned enhancement is to provide guidance on valid depth and Kd ranges when running the tool. For example, cBLUE might allow the user to compute TPU up to a depth that would be considered beyond the achievable limits for a given sensor, Kd, and wind speed; however, in doing so, it would generate a warning to the user. Further testing for stability, and comparison against the CZMIL "rule of thumb" uncertainty (which does not account for environmental conditions), are planned.

Since the beginning of the project, based in part on previous Center experience with adoption of TPU models in acoustic systems and data processing, it was obvious that outreach would be a significant component of the effort. The model has therefore been documented through a number of academic papers and conference presentations, and OSU and the Center have been active in promoting the effort within the community. As the models and concepts of TPU are now starting to be supported within the bathymetric lidar community, standardization and validation of models, and best practices, is seen to be very important with respect to vendor and client adoption. OSU, and the Center, are therefore help-

ing to support development and documentation of best practices through stakeholder meetings (e.g., at the JALBTCX coastal lidar mapping workshop, as above), and via interaction with the ASPRS working group that maintains the specification for the LAS file format typically used for data processing and archive.

While computing TPU for survey data is in itself an important step towards quantitative and objective data understanding, it also has significant implications for processing of the data. Current processing paradigms for bathymetric lidar data often inherit from topographic workflows and rely on individually classified lidar observations much in the same way as acoustic hydrographic data processing used to. While there may be some applications which require this type of product, such methods are time consuming, error-prone, and often rely on subjective human hand-classification. Available TPUs are the gateway to more objective, semi-automated processing (such as that described in the following project), and effort has therefore been expended on ensuring that the outputs of the TPU model flow into the Center's processing methods. This has included detailed discussions with RSD, JALBTCX, and the Naval Oceanographic Office on workflow retooling, and the start of a LAS-file interface (via the "ExtraBytes" component) for uncertainty ingestion. The process is continuing.



**Automatic Data Processing for Topobathy Lidar Data**

The volume of data generated by modern topobathy lidar systems is immense. Any particular “lift” (i.e., a single flight) could entail collection of perhaps three billion observations (at the lowest capture rate available), which are recorded as several hundred gigabytes of digital records. Even moving the data from place to place is therefore problematic, and most data processing systems designed for hydrographic work respond poorly to this volume and density of data. Current data processing workflows for NOAA lidar data utilize conventional terrestrial lidar processing modes, where each observation is given a classification label to indicate its likely nature (e.g., “road,” “building,” “noise,” or “seafloor”). Class labels are added primarily by automated scripts and are then adjusted manually if required. In order to facilitate this process, the lidar data is broken into 500x500m grid tiles; once all labels are assigned, all observations corresponding to bathymetry can be extracted, and product grids generated.

While workable, this process can be extremely time consuming, and much of the time is taken by computer-based processing rather than interactive inspection of data, making it ripe for further automation. In addition, inspection of data processed by this method readily demonstrates that many otherwise plausible data points that appear consistent with those labeled “bathymetry” are labeled as “noise” or “unclassified.” To some extent this is expected—

automated classification scripts are readily fooled, especially in shallow water environments with lots of water column noise, but this means that not all of the available information from the dataset is being exploited. Consequently, new processing strategies are required.

Almost since its inception, JHC/CCOM has worked to develop semi-automated processing schemes for hydrographic data, culminating in the CUBE and CHRT processing algorithms, which are widely available in commercial software implementations. These algorithms are focused primarily on high-density acoustic data, generally from multibeam echosounders, and aim to provide gridded data products, with associated uncertainty and other metrics, as their primary outputs. In the past, density of data from strictly bathymetric lidar systems has generally been insufficient to allow them to be considered within the same processing scheme. The data from topobathy lidars, however, appears to be just as dense, or denser, than the typical input data for these algorithms.

In the previous reporting period, therefore, Brian Calder began adapting CHRT to the topobathy lidar data processing problem, and demonstrated that it was possible to extend the basic algorithm with a new “level of aggregation” approach to resolution determination (see Task 13) and machine learning (ML) based methods (specifically a vector-quantized Hidden Markov Model) to provide clean first-pass estimates of depth from raw data, Figure 17-7. In addition to being objective, this approach significant-

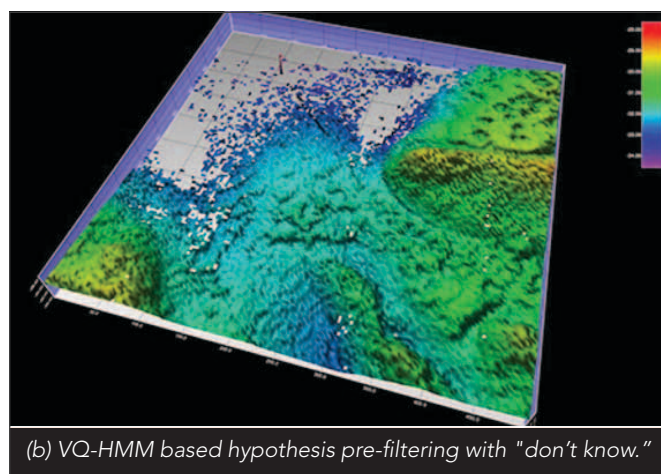
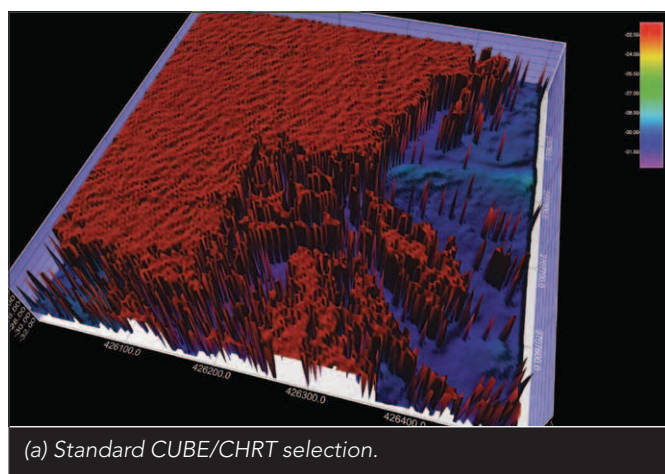

Figure 17-7. Example of depth reconstruction using acoustic-inspired selection rules (a), and the (revised) VQ-HMM approach (b), based on raw (unclassified) LAS files. The noise points in the “standard” selection method (a) are mis-selected reconstructions caused by the density of noise, or lack of actual data, at the estimation points; red points are reconstructions due to surface noise. The VQ-HMM method (b) pre-filters hypotheses and opts to not reconstruct if there are none which resemble the training set’s idea of a sea floor hypothesis.

ly reduces the user interaction time, and provides an acoustic-compatible workflow for lidar.

In the current reporting period, the research moved, with Kim Lowell, to the use of data analytics to enhance the lidar algorithm (and CHRT, Task 13, in general). When choosing among hypotheses, current CHRT disambiguation rules rely on metrics such as the number of observations per hypothesis or the depth determined for one or more neighboring grid points. Implicit in such rules is that all lidar observations have an equal *a priori* likelihood of being bathymetry. The ML approach being developed seeks to assign to each return an *a priori* probability of being bathymetry— $p(\text{Bathy})$ —that is incorporated into the disambiguation rules. This “certainty index” will ultimately be used within CHRT to influence the decision about which hypothesis for a grid point is considered most likely.

As an illustration, Figure 17-8, consider an estimation node with three depth hypotheses—4, 7, and 10m—that have been developed from the all of the data associated with the estimation node. Current disambiguation rules might accept Hypothesis 1 (4m depth) because it has the most observations incorporated. However, if a reliable estimate of  $p(\text{Bathy})$  were available for all returns, as shown, Hypothesis 2 (7m depth) might be accepted instead.

Scientifically, the viability of this approach is dependent on obtaining a useful estimate of  $p(\text{Bathy})$ ; operationally it depends on estimating  $p(\text{Bathy})$  from the lidar point cloud alone, i.e., without using ancillary data such as existing bathymetric charts. The effort in this reporting period has therefore focused on methods to improve the preliminary classifications, and technical details of the implementation methods which might assist in performance improvements.

To identify features that can be used to augment the  $p(\text{Bathy})$  detection, the ML approach is currently using three types of meta-data associated solely with the lidar point cloud:

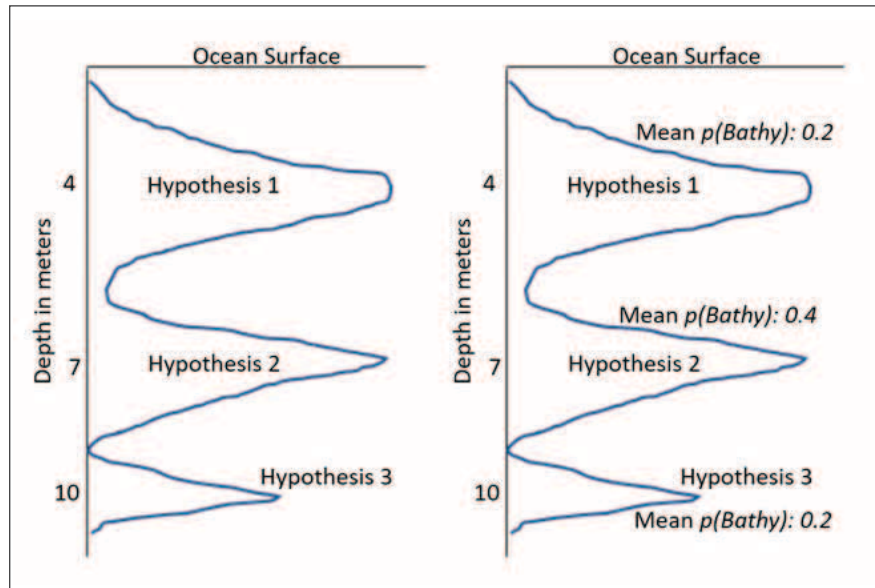

Figure 17-8. Conceptual model motivating the use of  $p(\text{Bathy})$  to augment the CHRT hypothesis disambiguation rules.

- **Pulse-specific:** As part of the LAS data standard, each return is tagged with information such as whether it is a single return, or the first (or second, or third, etc.) of many returns. Also employed is the angle of the generating pulse relative to flight path direction.
- **Flight path stability:** It is surmised that the stability of the airplane platform and the linearity of the flight path are indicative of wind conditions at the time of data acquisition which in turn may affect the sea surface and the reflectance of lidar pulses. Hence the following data are employed:
  - **SBET:** Smoothed Best Estimate of Trajectory files provided with the lidar return data include the uncertainties of the X, Y, Z location of a plane and its yaw, pitch, and roll at 200Hz. These are assigned to individual returns based on time of acquisition.
  - **Crenularity:** The degree to which the data edges are rough is considered as a proxy for lidar beam (or scanner) movement during flight. This is estimated as the orthogonal distance between lidar returns on the edge of the swath, and a “straight line” path along the edge, Figure 17-9. This deviation is assigned to each return based on acquisition time.

- Topographic Characteristics:** The configuration of the seafloor could potentially affect the bathymetry probability. Various characteristics—e.g., depth, slope, and orientation—are obtained by applying spatial interpolation and extrapolation to the points identified by NOAA as “ground truth” bathymetry, Figure 17-10. Orthogonality of pulse direction and incident angle to slope steepness and orientation are also derived. These are assigned to each pulse return using spatial overlay.

The ability of these meta-data to provide a reliable  $p(Bathy)$  estimate has been evaluated for four 500x500m tiles near the Florida Keys (RSD project FL1611-TB-N, 2016). Three ML techniques have been used to develop models to classify returns as *Bathy/NotBathy* as determined by NOAA standard operating procedures. The three techniques are: regularized logistic regression (RLR), multi-layer perceptrons (MLP, a type of neural network), and extreme gradient boosting (XGB, a tree-based classifier). All produce an estimate of  $p(Bathy)$  that is subsequently used to classify each return as *Bathy* or *NotBathy*. The accuracy of this classification is then assessed using standard confusion matrix approaches.

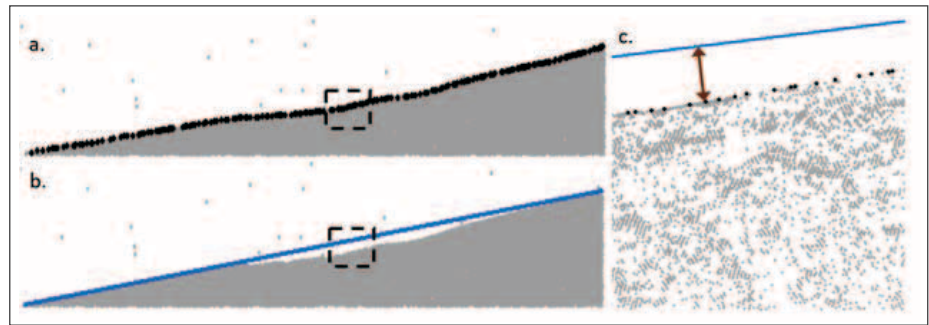

Figure 17-9. Estimation of the crenularity of the lidar returns from a given flightline. The crenularity is estimated as the orthogonal difference (c) between lidar points considered to be the edge of the swath (black points (b), dashed box zoomed in (c)) and the “straight line” path (blue) fitted to the edge.

It was clearly demonstrated that:

- The *Bathy/NotBathy* signal in the meta-data is sufficiently strong to warrant exploration of its impact on CHRT disambiguation rules in operational workflows. (R2 averages about 0.70 ( $n = 1,000,000+$ ); global classification accuracy is approximately 80%).
- XGB models outperform RLR and MLP both for accuracy and speed of model development and application.
- All three variable suites—pulse-specific, flight path stability, topographic characteristics—are represented in the best model for each tile.
- The individual variables that are important in the models fitted vary by tile with no discernible

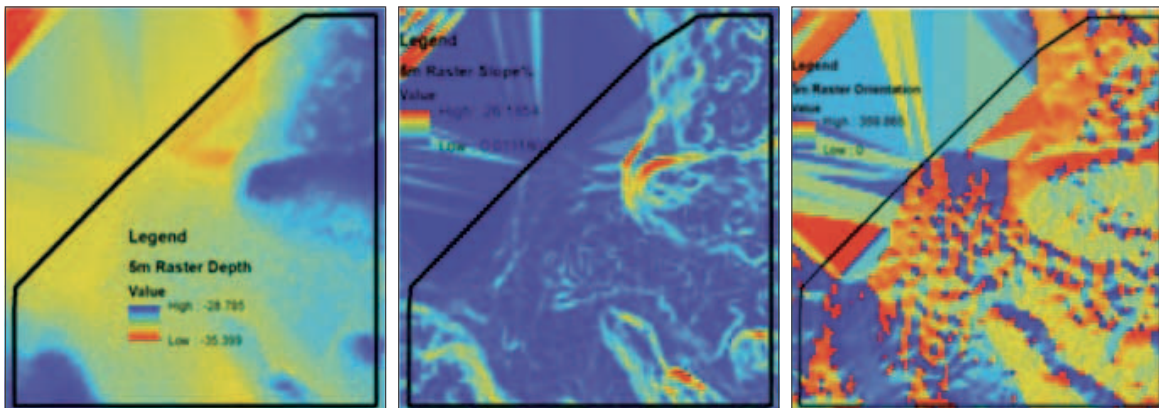

Figure 17-10. Estimation of depth, slope, and orientation using interpolation and extrapolation from RSD ground-truth, used to provide topographic metadata for the analysis. Black outline shows extent of the ground-truth data.



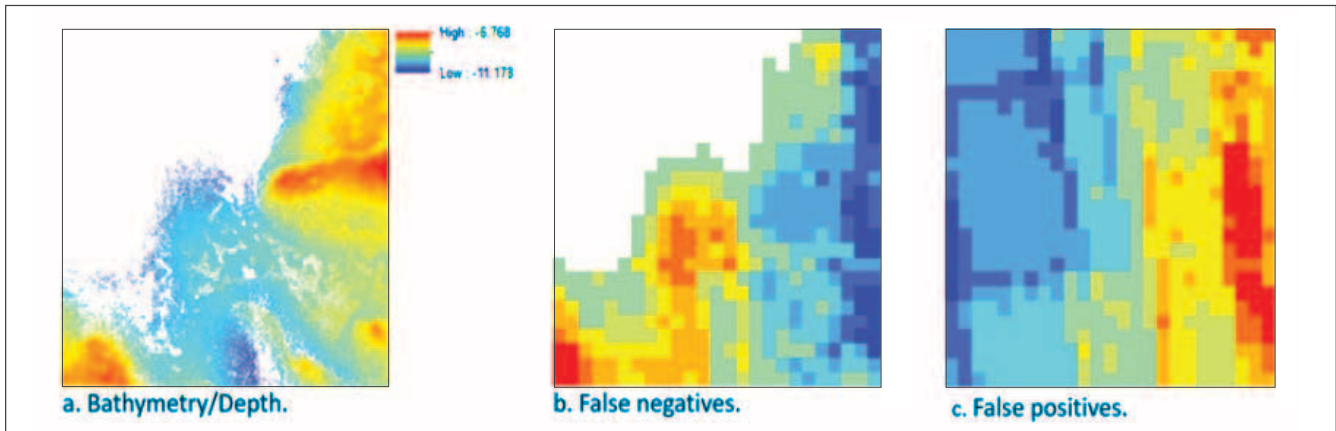

Figure 17-11. Spatial distribution of bathymetric lidar pulse returns (a) and FNs (b) and FPs (c) associated with the model for the Deeper data tile. In (b) and (c), hot colors indicate an abnormally high number of errors; cool colors indicate an abnormally low number of errors.

tendency relative to depth, topographic characteristics, or percentage of points identified by NOAA as bathymetry.

- A significant issue identified in this pathfinder work was a severe *Bathy/NotBathy* imbalance (according to NOAA classification) in lidar point clouds. This imbalance causes globally optimized ML models to improve the accuracy of the majority class (often *NotBathy*) at the expense of the accuracy of the minority class (often *Bathy*). For hydrography, however, this is often not the optimal answer. A number of different approaches to this problem are possible, including observation augmentation techniques (e.g., SMOTE or ADASYN), and importance weighting. However, the approach developed here, which successfully addresses this issue without extra computational burden, is to apply an “optimal probability decision threshold” (OPDT) to the  $p(\text{Bathy})$  values produced by XGB models. Conventionally, a threshold of 0.50 is adopted, i.e., for each pulse return, if  $p(\text{Bathy}) > 0.50$

then *Bathy* else *NotBathy*. The OPDT is the point at which the false negative rate (FNR: undetected *Bathy*) equals the false positive rate (FPR: erroneously detecting noise as *Bathy*).

A further potential enhancement, using a decomposition of the confusion matrix for any tile, was investigated. The initial goal was to iteratively use subsets of the data to highlight weaknesses in the analysis, and correct them with further models. Detailed investigation demonstrated that this approach was not likely to be productive, however.

Recognizing that operational quality assurance and continuous improvement requires better knowledge

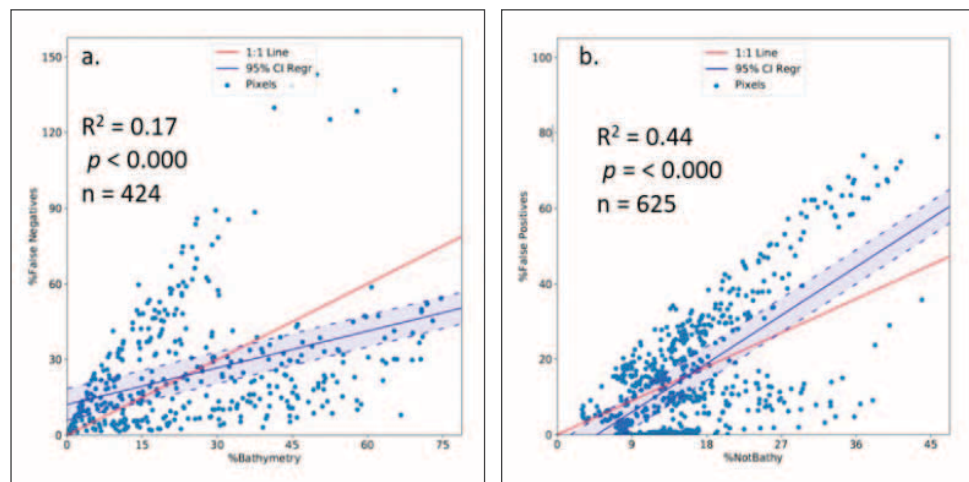

Figure 17-12. Regression lines for the Deeper tile for the percent of errors (FNs or FPs in (a) and (b), respectively) in a pixel relative to its expected percentage (*Bathy* or *NotBathy* for (a) and (b), respectively).

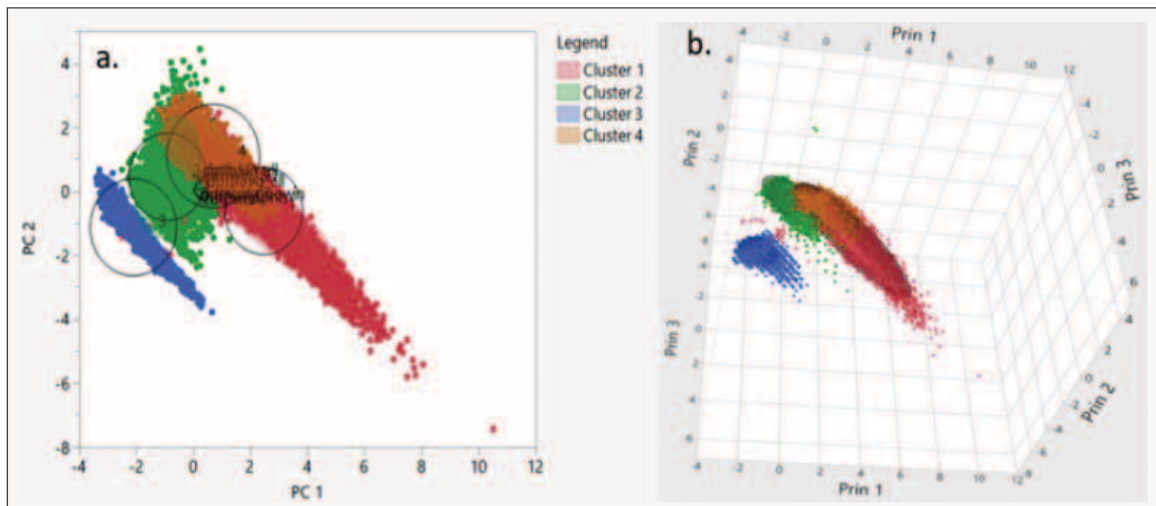

Figure 17-13. Example of normal mixtures clustering for the Deeper tile using four classes.

of model performance, the spatial distribution of errors was also examined. A method has been developed that provides for rapid identification of areas having an abnormally high error rate; the ultimate goal is to provide this information to operators, allowing for rapid analysis of where further work may be required.

The method comprises dividing an area into (relative) coarse pixels and comparing the percent of total pulse returns of a given type—*Bathy* or *NotBathy*—against the percent of total errors of a particular type, i.e., FNs for *Bathy* and FPs for *NotBathy*. The comparison is made visually (Figure 17-11) and statistically (Figure 17-12).

It is quickly apparent that, for example, the eastern edge of the Deeper tile has an abundance of FPs but a lower number than expected FNs. The disagreement between observed and expected over the whole tile is apparent in Figure 17-12:  $R^2$  values are low (though significant), and the fitted lines do not adhere closely to the 1:1 line that indicates perfect agreement. The disagreement between actual and expected may be related to geographically explicit poor model performance, or to errors in NOAA's *Bathy* classification. Regardless of the cause, these figures provide useful information for improving both the model and NOAA's *Bathy* classification.

The ultimate goal of the methods being developed are to augment the CHRT hypothesis selection algorithm for very high levels of noise. Towards the end of the reporting period, therefore, focus has shifted to operationalization integration with CHRT.

Though CHRT selects a “most likely” depth hypothesis for a grid of “estimation nodes” (ENs) over an area using known selection rules, it is unknown if the best estimate of depth for a given EN is *Bathy* or *NotBathy*. Lowell is therefore exploring whether unsupervised clustering can separate *Bathy* ENs from *NotBathy* ENs using EN-specific descriptors such as the total number of pulse returns, average depth of pulse returns, and associated variances. Normal mixture clustering is the initial focus of this work as it estimates the probabilities that each EN belongs to a given cluster. Figure 17-13 visualizes the concept. The EN descriptor data clearly indicate that there are no *Bathy* ENs in the readily separated blue cluster, and cluster probabilities indicate there is no confusion with the other three clusters. However, the remaining three clusters all contain a mixture of ENs that are *Bathy* or *NotBathy*. A reliable method for identifying which of the ENs in both pure and mixed clusters is being explored and will be one focus during the next reporting period.

In parallel with the CHRT integration effort, Calder and Lowell have continued to develop a collaboration with the UK Hydrographic Office Data Science team on other uses for ML and Deep Learning (DL) algorithms in hydrographic practice. The goal of the collaboration is to determine a functional combination of conventional processing techniques and ML/DL techniques to enhance (and assess) accuracy of processing for all types of bathymetric data. After an in-person visit (2019-10) at the UKHO, a rough project outline has been agreed; project development is expected to continue.

## THEME 1.B.2: Identification and Mapping of Fixed and Transient Features of the Seafloor and Water Column

### Sub-Theme: SEAFLOOR

**TASK 18: Hydro-Significant Object Detection:** *Develop algorithms to automatically detect objects attached to the seafloor that might be hydrographically significant and, if possible, to determine their character (e.g., natural or anthropogenic) using all available sources of data, including information about the local environment. Provide directed visual feedback to the user, ideally in a quantitative manner, on the objects in the area that might be hydrographically significant, preferably in order from most significant to least; and to seed geodatabases with the information in a manner that addresses downstream use of the detections. Investigate the development of tools that address the issue of correlation between different data sources for the objects detected, both algorithmically and visually, so that objects can be tracked over time and compared with prior information on location.*

Pls: **Brian Calder and Giuseppe Masetti**

JHC Participants: Larry Mayer, Larry Ward, and Zach McAvoy

Other Collaborators: Derek Sowers (NOAA OER)

Detection and management of objects in a hydrographic workflow can be a significant resource burden. Hydrographically significant objects are often small and close to the skin-of-the-earth bathymetric surface and are therefore difficult to identify in survey data. In addition, once potential objects are identified, they have to be correlated to other sources of information and then managed throughout the pro-

cessing lifetime of the survey. Algorithms to identify, classify, and manage such objects are therefore beneficial to efficient survey operations and down-stream data processing.

In the context of the QC Tools project (see Task 15), JHC/CCOM have developed a number of algorithms to detect “fliers” in bathymetric data, defined as

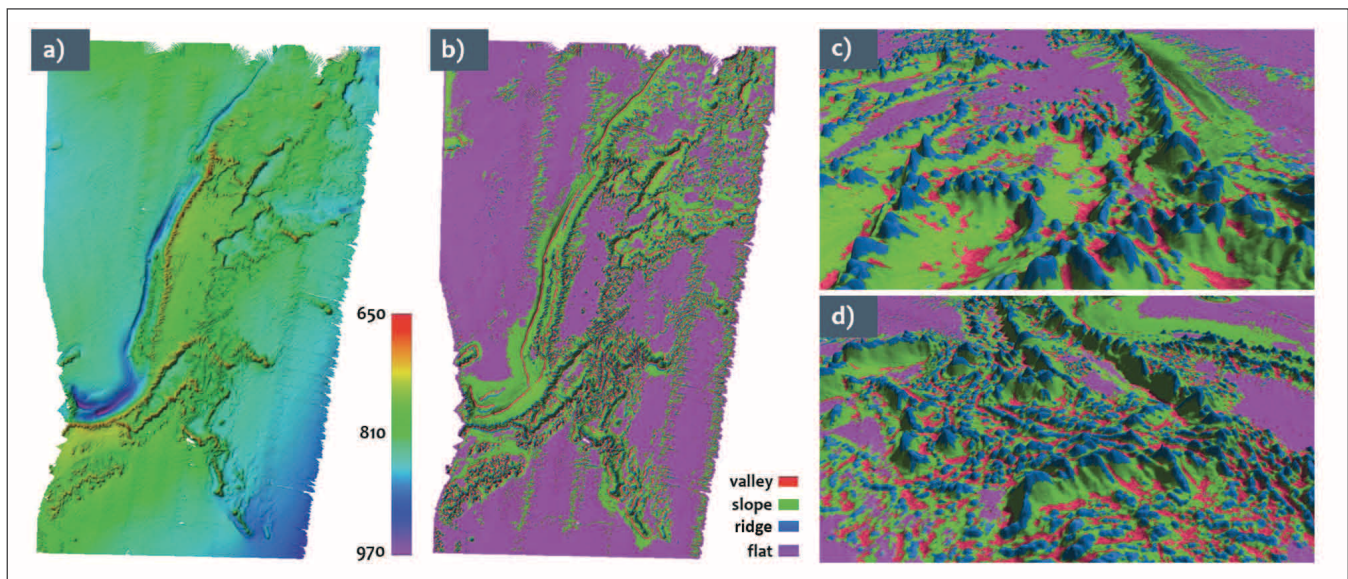

Figure 18-1. Example of BRESS usage. Pane ‘b’ shows seafloor landform features as delineated from, and draped over, bathymetric data of the Richardson Reef area (pane ‘a’). This area was mapped in detail in 2018 by NOAA Ship *Okeanos Explorer*, with further follow up investigations conducted by both NOAA’s Office of Ocean Exploration and the DEEP Sea Exploration to Advance Research on Coral/Canyon/Cold seep Habitats (DEEP Search) team funded by the National Oceanographic Partnership Program. The mound and ridge features in this area form a massive deep-sea coral reef stretching at least 85 miles long off the coast of Charleston, South Carolina. The blue features (‘shoulder’ landforms) in the map are ridge features identified using BRESS (zoomed areas are provided in in pane ‘c’, for the northern area, and pane ‘d’, for the southern area). The identification of the ridge crests is useful because it identifies the most likely places to support dense deep-sea coral communities. This detailed spatial information may improve coral habitat predictive models and helps quantifying the potential areas suitable for supporting this habitat type in the region.



-/+	0	1	2	3	4	5	6	7	8
0	FL	FL	FL	FS	FS	VL	VL	VL	PT
1	FL	FL	FS	FS	FS	VL	VL	VL	
2	FL	SH	SL	SL	CN	CN	VL		
3	SH	SH	SL	SL	SL	CN			
4	SH	SH	CV	SL	SL				
5	RI	RI	CV	CV					
6	RI	RI	RI						
7	RI	RI							
8	PK								

**a)**

-/+	0	1	2	3	4	5	6	7	8
0	FL	FL	FL	FS	FS	VL	VL	VL	VL
1	FL	FL	FS	FS	FS	VL	VL	VL	
2	FL	SH	SL	SL	SL	VL	VL		
3	SH	SH	SL	SL	SL	SL			
4	SH	SH	SL	SL	SL				
5	RI	RI	RI	SL					
6	RI	RI	RI						
7	RI	RI							
8	RI								

**b)**

-/+	0	1	2	3	4	5	6	7	8
0	FL	FL	FL	SL	VL	VL	VL	VL	VL
1	FL	FL	SL	SL	VL	VL	VL		
2	FL	SL	SL	SL	SL	VL	VL		
3	SL	SL	SL	SL	SL	SL			
4	RI	RI	SL	SL	SL				
5	RI	RI	RI	SL					
6	RI	RI	RI						
7	RI	RI							
8	RI								

**c)**

Figure 18-2. Variant classification tables for BRESS. The four-type classification table (pane 'c') was derived from the six-type classification table (pane 'b') with modification in red. In turn, the six-type classification table (pane 'a') represents a marine-adaptation of the land-based classification provided by Jasiewicz and Stepinski (2013). Landform types: FL for Flat, PK for Peak, RI for Ridge, SH for Shoulder, CV for Convex Slope, SL for Slope, CN for Concave Slope, FS for Foothlope, VL for Valley, PT for Pit.

points in the bathymetric surface that are not consistent with the surrounding terrain. Although the intent is different, there is an obvious similarity between this process and identification of "objects," and adaptation of such techniques of object detection may be a fruitful line of exploration.

Recognizing that spatial context in detection is likely to be important in the development of future object detection algorithms, Masetti, Larry Mayer, and Larry Ward have recently started a project to automatically segment the seafloor in homogeneous areas through

a combination of information from both backscatter and bathymetric observations. The performance of detection algorithms for objects (e.g., in the mine countermeasures community) is known to often be data-set specific. That is, algorithms that work well in the context of one data-set may not translate well to another without at least re-estimation of parameters. A robust algorithm, therefore, needs to be able to understand its background in order to adapt; in essence, the algorithm needs to be taught what the different haystacks look like before trying to find the needles.

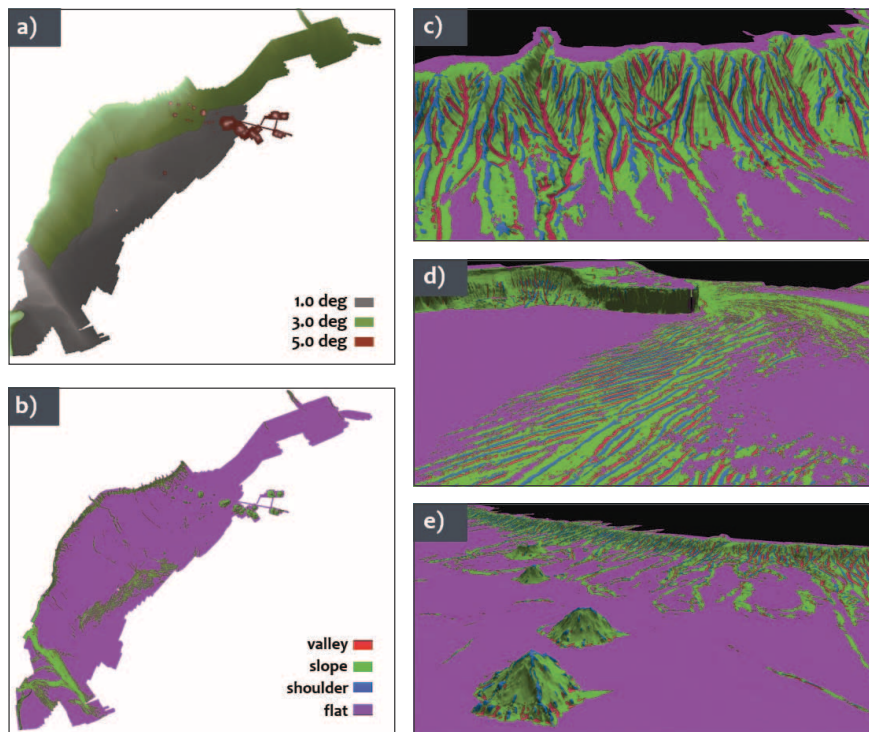

Figure 18-3. Application of hand-crafted flatness parameter modulations to the Atlantic Margin ECS data. Pane 'a' shows the flatness parameter mask used to apply different flatness values of the BRESS landform algorithm to different regions. A value of 5.0 degrees (red) is applied to the seamounts, 3.0 degrees (green) to the continental slope, and 1.0 degrees (grey) to abyssal areas. Bathymetry data shown in the background for context. Pane 'b' shows the resulting continuous coverage landform map classified into four landform types: flats (purple), slopes (green), ridges (blue), and valleys (red). Oblique 3-D views (pane 'c', 'd', and 'e') of landform type draped on bathymetry (vertical exaggeration of 6x) provided to show details. Note the clear delineation of continental slope canyon ridge, valley, and steep slopes features (pane 'c'). Seamount features are dominated by very steep slopes with occasional ridge and valley features (pane 'e'). Several large regions of the abyssal plains exhibit dramatic bedform features that follow a distinct pattern of repeating slope and ridge combinations. Pane 'd' highlights one of these bedform fields east of the prominent Blake Spur feature.

The proposed method attempts to mimic the approach taken by a skilled analyst, that first evaluates the context of the area, attempting to take full advantage of both bathymetric and reflectivity products rather than focusing on small-scale geomorphometric variability (e.g., local rugosity). The result is a bathymetry- and reflectivity-based estimator for seafloor segmentation (BRESS) that models these positive aspects of the analyst's segmentation methods but avoids the inherent deficiencies such as subjectivity, processing time, and lack of reproducibility. The initial phase of the algorithm performs a segmentation of the DTM surface through the identification of contiguous regions of similar morphology, for example valleys or edges (Figure 18-1). The backscatter for these regions is then analyzed to derive final seafloor segments by merging or splitting the regions based on their statistical similarity. The output of BRESS is a collection of homogeneous, non-overlapping seafloor segments, each of which has a set of physically-meaningful attributes that can be used for task-specific analysis (e.g., habitat mapping, backscatter model inversion, or change detection).

During 2019, several improvements have been introduced to the original algorithm. In collaboration with Derek Sowers (NOAA OER), a four-type classification table for broad-scale landform classification has been introduced (Figure 18-2) in addition to the two that were already available (respectively, ten-type and six-type classification tables). Development efforts have been focusing on the flatness input parameter, making it possible to have different threshold values

in different areas of the input grid. Sowers has applied this technique to the Atlantic Margin ECS data (Figure 18-3—see Task 50 for further discussion). Finally, an algorithm to automatically compute flatness parameter values that adapt across a bathymetric terrain model have been developed and tested (Figure 18-4).

The BRESS output is a collection of preliminary, homogeneous, non-overlapping seafloor segments of consistent morphology and acoustic backscatter texture. Geomorphology classification represents a fundamental step in translating bathymetry into value-added spatial data of use for ocean managers, a primary basis for generating seascape maps, and an informing layer for predictive habitat models. During 2019, the output of each labeled segment was enriched by a list of derived, physically-meaningful attributes (e.g., median backscatter value, average height variance, standard deviation of the elongation ratio) that can be used for subsequent task-specific analysis. An application paper ("Applying a Standardized Classification Scheme (CMECS) to Multibeam Sonar and ROV Video Data on Gosnold Seamount") using the BRESS algorithm has been published as a section of the *GeoHab Atlas of Seafloor Geomorphic Features and Benthic Habitat*. Finally, another article, with title "Standardized Geomorphic Classification of Seafloor within the United States Atlantic Canyons and Continental Margin" and containing the latest BRESS improvements, has been submitted to *Frontiers in Marine Sciences*.

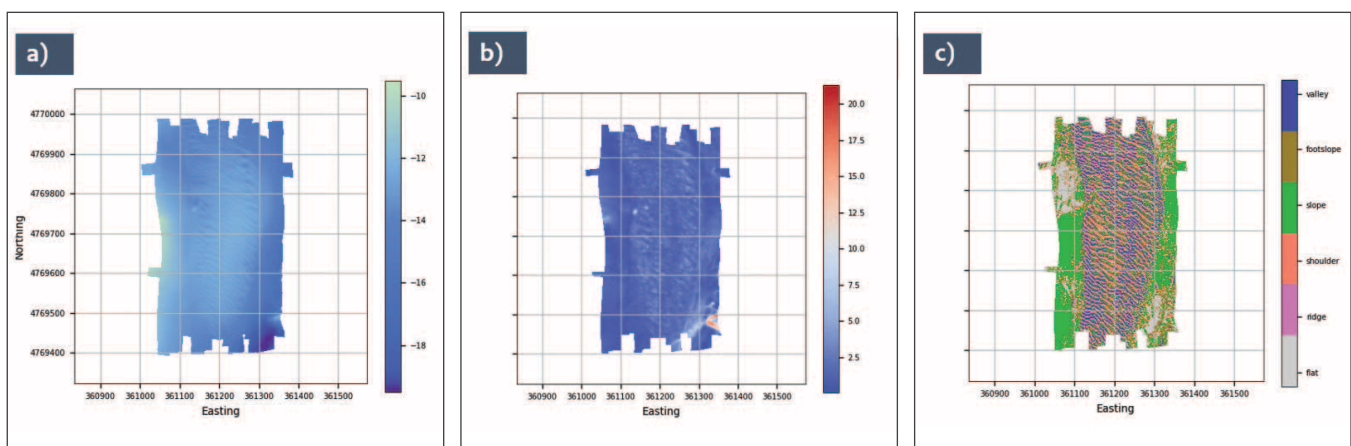

Figure 18-4. Experimental algorithm to automatically determine a spatially-adaptive flatness parameter. Pane 'a' shows the input bathymetry (values in meters). In pane 'b', the adaptive flatness threshold values (in degrees) are visualized, obtained by retrieving the 25th percentile among all the valid slopes surrounding each node, then applying Gaussian smoothing. Pane 'c' shows the resulting landforms based on a six-type classification table.

**Sub-Theme: WATER COLUMN**

**TASK 19: Water Column Target Detection:** Continue the development of algorithms for the detection, processing, extraction and visualization of water column targets from the new generation of sonars that provide water column data. Work with our industrial partners to help make this workflow a reality. **PI: Tom Weber**

**JHC Participants:** Erin Heffron and Elizabeth Weidner

This past year has presented a number of opportunities to collect water column data and further our development of processing and visualization approaches. One of the foci for water column target detection was a research cruise in New Zealand on the R/V *Tangeroa*, an output of the CATALYST Water Column Acoustic Workshop in Rennes, France, in July 2018. Center participation in the cruise was funded outside of the JHC grant, however the cruise presented a tremendous opportunity to collect and process water column data. The cruise involved the use of a large suite of acoustic echo sounding equipment for quantitatively assessing both the seafloor and the water column, including several broadband split-beam echo sounders operating at frequencies ranging from 15-25 kHz, a 30 kHz EM302, and a 200 kHz EM2040.

Ground truth data were collected using a camera tow-sled and water sampling. The Center contributed a synthetic gas bubble generator, developed by former student Kevin Rychert with funding from NSF (Figure 19-1), which was used to test detection limits and to perform cross-calibrations between different systems.

Graduate student Elizabeth Weidner analyzed bubble generator data collected as part of a dedicated experiment aimed at calibrating multibeam water-column backscatter measurements with the pan and tilt system (PTS) split-beam echosounder system. The bubble generator provides a single bubble stream consisting of bubbles of constant size (defined by the user-set differential pressure threshold value)

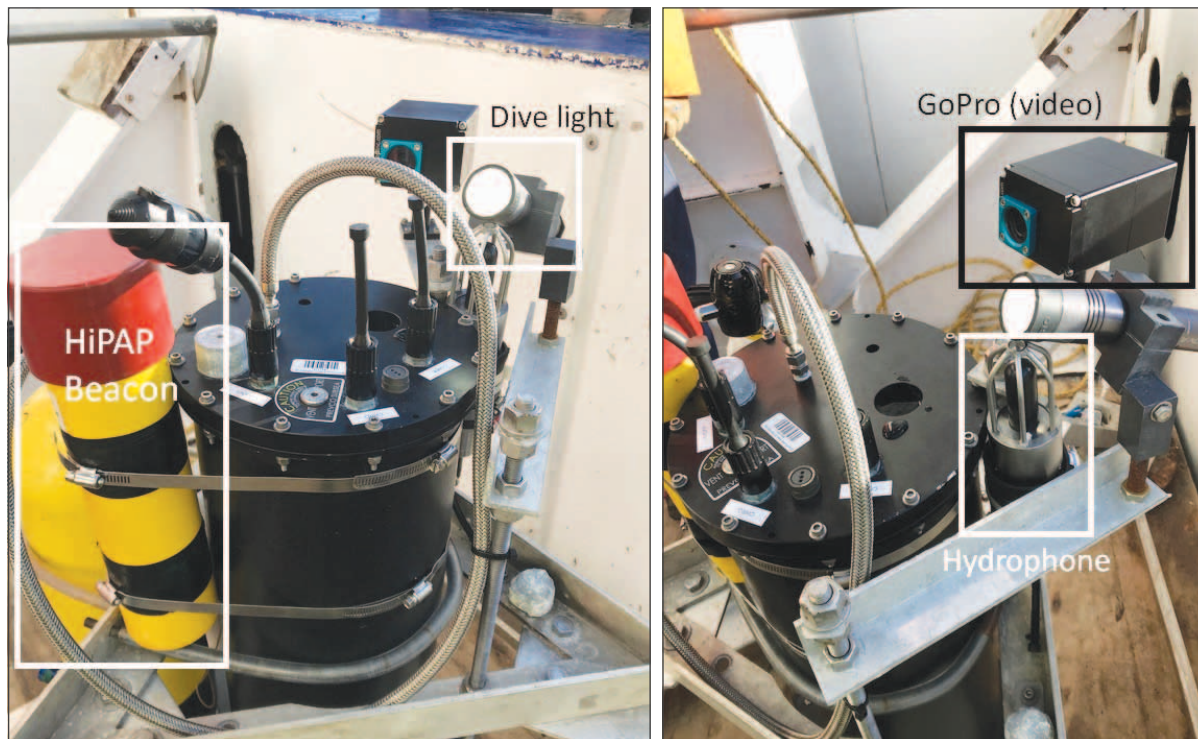

Figure 19-1. The bubble generator and auxiliary equipment employed during bubble generator deployment operations: positioning beacon, video camera/dive light, and hydrophone.



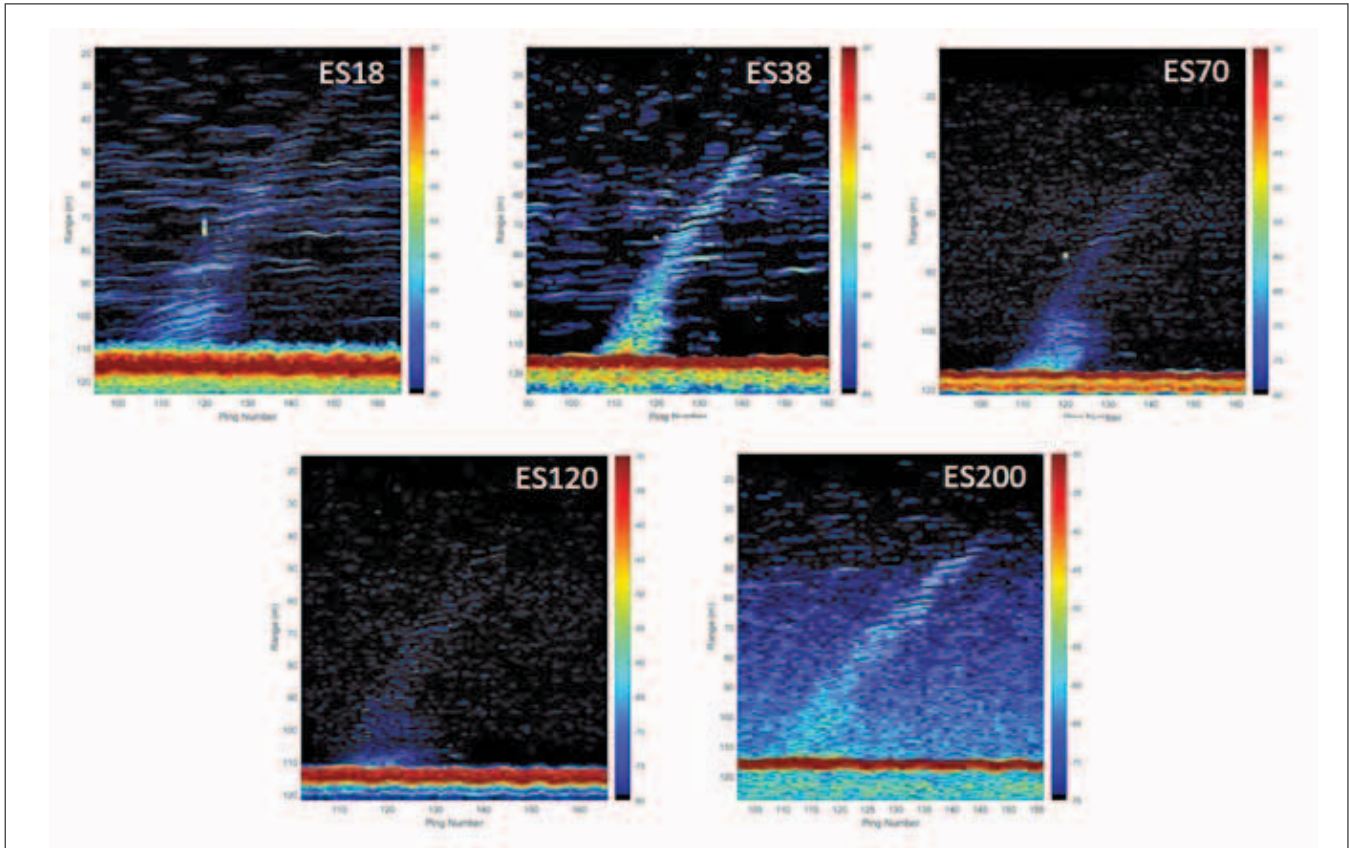

Figure 19-2. Echograms showing the bubble stream in the hull-mounted systems.

and release rate (set by the user pre-deployment). Ensonifying the bubble stream simultaneously with the hull mounted multi-beam echosounder systems (EM302 and EM2040) and the calibrated split-beam echosounder (ES200) on the pan & tilt system provides directly comparable datasets. The goal of the research project was to determine whether data collected with a calibrated split-beam system at various angles can be used to calibrate MBES watercolumn data at the same ensonification angles (Figure 19-2). During the first two passes over the bubble generator, a bubble stream of individual bubbles was identifiable in all five systems, including the hull-mounted ES200 (Figure 19-2). In subsequent lines the hull-mounted ES200 was put into passive mode and the ES200 on the PTS was active. A series of increasingly offset parallel lines were run and the incident angle of the PTS was correspondingly increased with the increasing offset.

Data collected at all angles of the PTS ES200 system were analyzed using proprietary MATLAB software scripts. The bubble streams were identified by a series of individual scatterers made up of a series of peaks in acoustic amplitude, nearly-constant rise rate (positive slope from ping-to-ping), and equivalent separation (corresponding to constant release rate). Individual bubbles were sampled at the point of maximum acoustic response. The bubble range, electrical phase angle, peak acoustic intensity, and vessel motion were extracted (Figure 19-3). Bubble position was estimated using the range and electrical phase angle, as well as correcting for the vessel motion. Bubble target strength was computed by applying the beam-pattern specific calibration offset, determined from the electrical phase angle. Bubble radii for each detection were computed through comparison to acoustic scattering models, to provide co-authors with bubble size as a function of

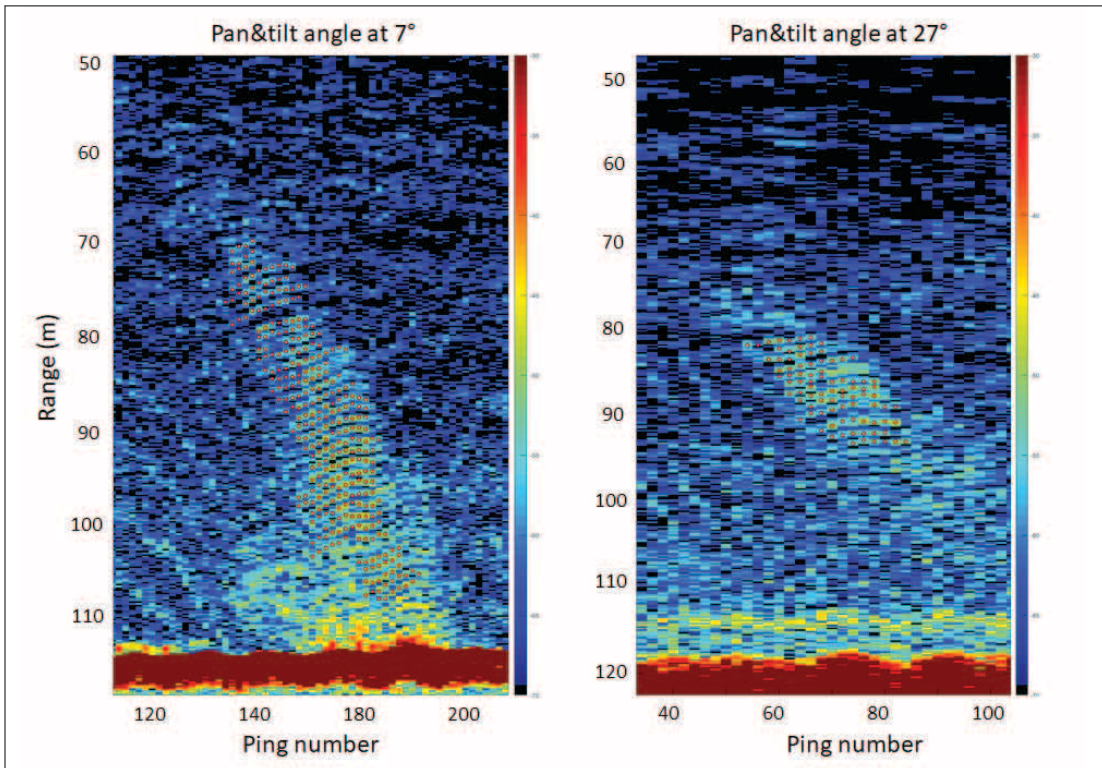

Figure 19-3. Examples of processes ES200 data from the pan&tilt system at 7 degrees (left) and 27 degrees (right).

water depth (Figure 19-4). Bubble radii near to the bubble maker release site were estimated to be approximately 3 mm and as the bubble rose through the water column they shrunk in size slightly, as expected for air bubbles in the ocean (minimum dissolution and lessening of hydrostatic pressure). The minimum radii was 1 mm at 32 meters depth.

**Hydrothermal Seep System Gas Flux Quantification**

In addition to the PTS bubble maker experiment, Weidner also completed work processing acoustic data over the a hydrothermal marine seep system imaged on the Tangeroa and provided estimates of volumetric gas flux and seafloor carbon dioxide flux.

The site there showed a strong frequency-dependent scattering in the water column (Figure 19-4). At the lowest frequencies vertical plume-like features were detected in the water column, rising from the seafloor to near the sea surface. As the frequency bands increased other plume-like features became apparent in the water column that

were not seen in the lower frequency data. These plumes moved primarily in a horizontal direction away from the seep site.

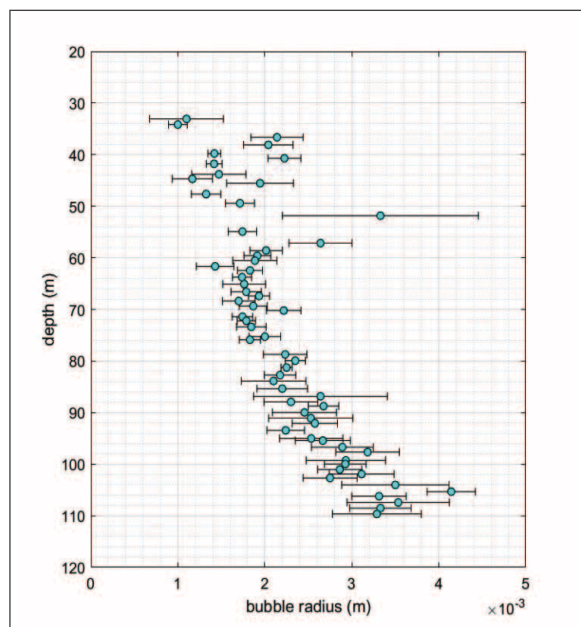

Figure 19-4. Derived bubble radii from a single ES200 pass.



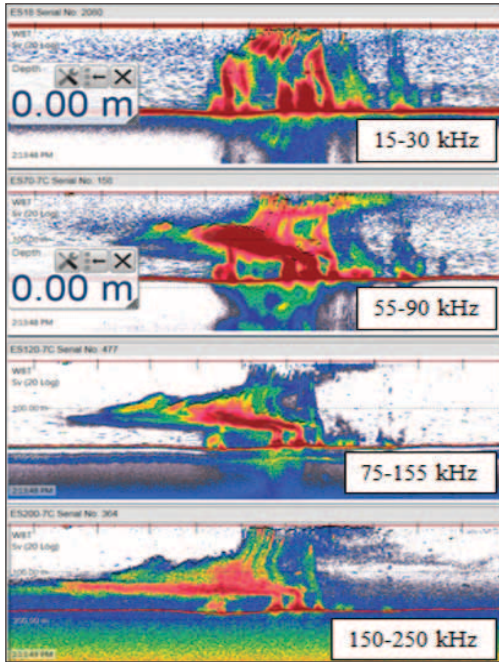

Figure 19-5. Multi-frequency response of the FOI-2 system.

Using the data from a series of passes over the vent system, individual bubbles were identified, their responses sampled, and their radii estimated (Figure 19-5, left) to estimate flux. From the combination of all estimated radii, the bubble size distribution of the system was determined for different depth bins in the watercolumn (Figure 19-5, right). The bubble radii data were group into depth bins 15 meters thick, starting from the deepest observed depth and moving upwards through the watercolumn. Based on results from bubble dissolution models, it is assumed that for a given bin that the bubbles are not changing measurably in radii; therefore, a bubble size distribution for the depths defined by the bin can be estimated from the bubble data. Data were fit to a Rayleigh distribution and from this distribution the mean bubble radii for each depth bin was estimated to be used in volumetric gas flux estimations.

Split-aperture processing was applied to the data to extract phase data on the observed plume features. Coherent scattering, in the form of a phase

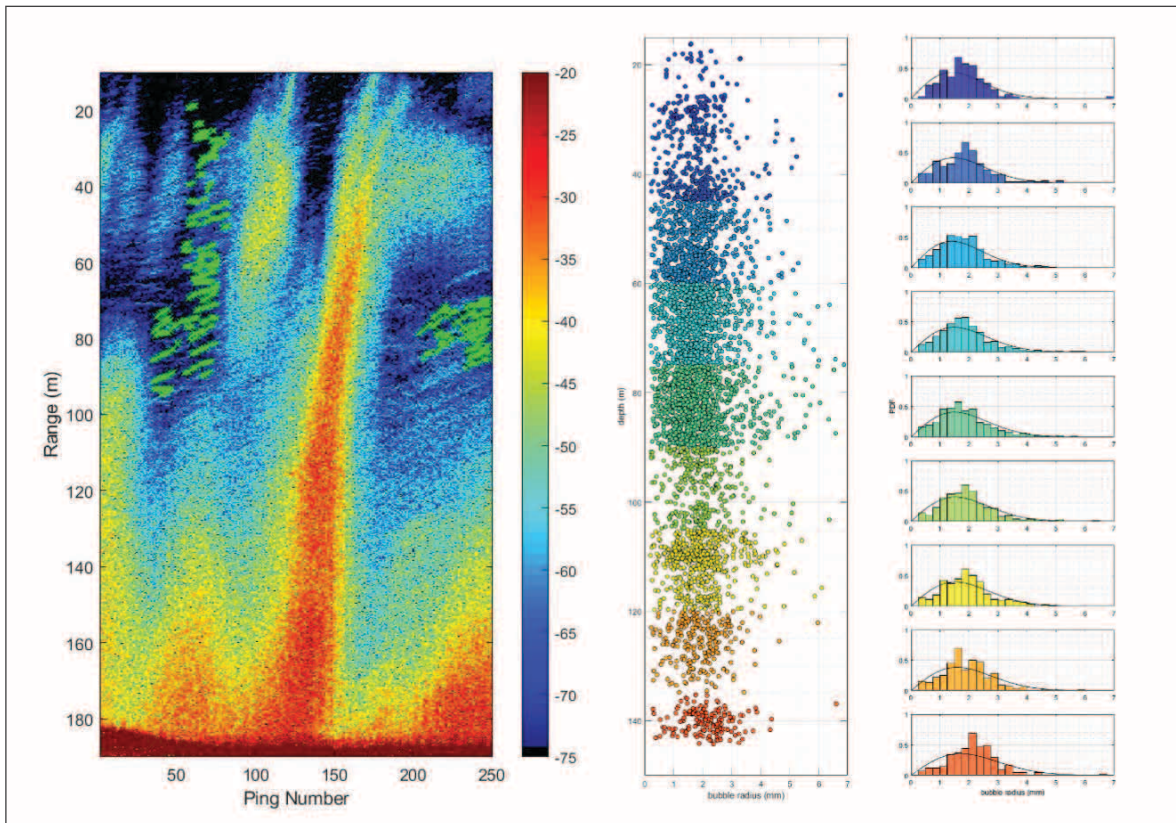

Figure 19-6. Single pass over vent and sampled single bubbles, marked as green 'x' (left). All estimated bubble sizes from the passes (left) and measured bubble size distributions with Rayleigh distribution fits overlaid (right).



ramp, from a plume feature suggests the plume is completely captured within the acoustic beam, allowing us to invert the acoustic data for an estimate of the number of bubble for a given depth bin. Following this, coherent plume features (in both along and across track phase data) were sampled in every pass across the vent system to estimate the mean gas flux (Figure 19-6).

There is a clear trend of decreasing volumetric gas flux as a function of depth (Figure 19-7), suggesting the gas bubbles being released from the seafloor are shrinking and dissolving away as they rise. This is mirrored in the bubble size distribution data, as the distribution move towards smaller bubbles higher in the water column. Bubble composition at the seafloor was based on previous research at the site. Gas composition was estimated as: 76% CO<sub>2</sub>, 16% air, 10% CH<sub>4</sub>, 1% H<sub>2</sub>S. Carbon dioxide release from the seafloor was estimated to be 146.4 ± 31.51 kg/day, from the data bin closest to the seafloor. This is a minimum estimation, as incoherent plume features were not sampled with this method.

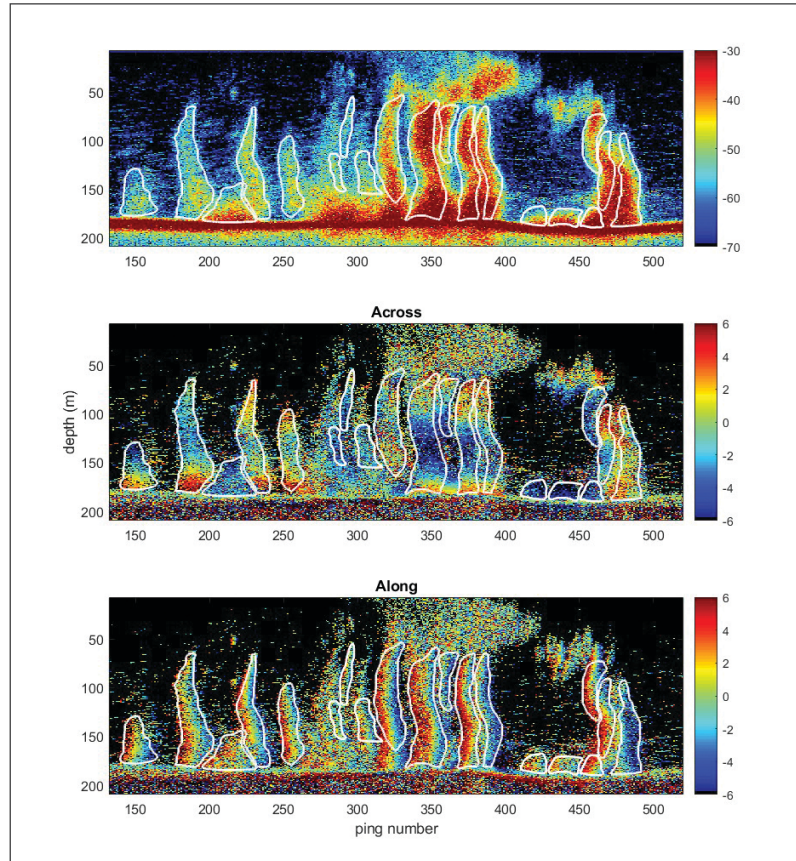

Figure 19-7. Example of sampled coherent plumes from the FOI-2 system. The upper panel is colored by target strength, while the middle and lower panel show the along and across track phase data.

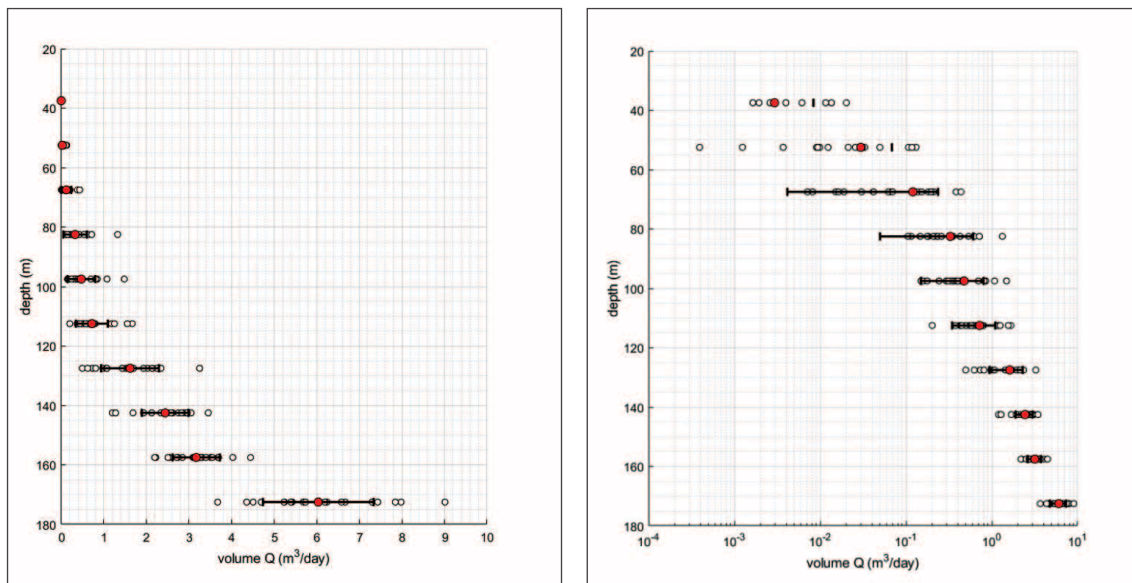

Figure 19-8. The estimated volumetric gas flux rates in each depth bin for the FOI-2 system. Linear flux rates on the left and logarithm flux rates on the right.

## Research Requirement 1.C: Seafloor Characterization, Habitat, and Resources

**FFO Requirement 1.C:** "Adaption and improvement of hydrographic survey and ocean mapping technologies for improved coastal resilience and the location, characterization, and management of critical marine habitat and coastal and continental shelf marine resources."

### THEME: 1.C.1 Coastal and Continental Shelf Resources Sub-Theme: RESOURCES

**TASK 20: Mapping Gas and Leaky Pipelines in the Water Column:** *Refine and enhance water column mapping tools to better understand our ability to map/monitor leaky systems and dispersed clouds of oil, with a focus on high frequency shelf-mapping systems, which present a more challenging environment with respect to volume reverberation.* PI: **Tom Weber**

**Project: Broadband Acoustic Measurements of Liquid Hydrocarbon Droplets and Gas in the Water Column**

**JHC Participants:** Scott Loranger, Alexandra Padilla, Kevin Rychert, Elizabeth Weidner, and Larry Mayer

**Funding:** This work has been funded by a combination of the JHC grant, BSEE (DOI), and NSF

In order to acoustically map, quantify, and monitor subsurface dispersed oil droplets, a better understanding of the broadband acoustic response of oil droplets is required. General models of the acoustic response of fluid-filled spheres exist, but have

not been empirically verified. Often, these models involve assumptions that could potentially limit their accuracy, such as a perfect spherical symmetry of the target, or require knowledge that is difficult to obtain, such as the density and sound speed of oil

at oceanographic temperatures and pressures. Accordingly, we are working on both tank experiments where we collect empirical observations of single oil droplets, using different types of crude oil, as well as laboratory measurements of crude oil density and sound speed.

Much of this work forms the basis for Scott Loranger's Ph.D. dissertation, which he successfully defended in November 2018 and completed in spring 2019. Loranger's work on oil physical properties (temperature- and depth-dependent sound speed, temperature-dependent density) has been published in the *Journal of the Acoustical Society of America* (JASA). A sec-

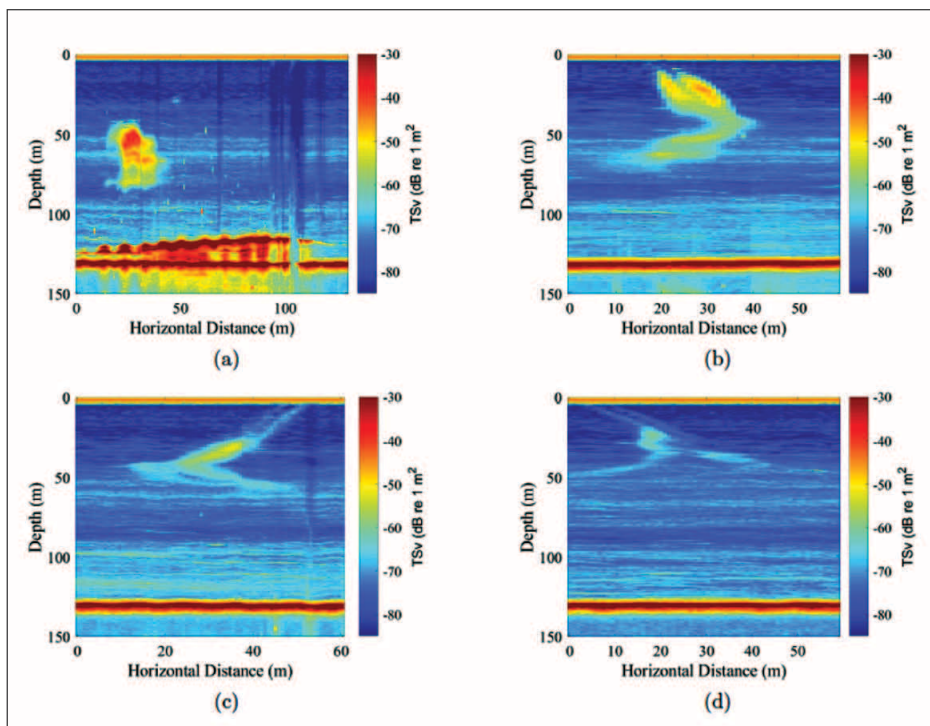

Figure 20-1. (Loranger's Figure 4.3, PhD dissertation). Echograms for cross sectional passes downstream of the Taylor seep origin. (a) is the echogram closes to the origin (58 m), followed by (b) (115 m) then (c) (187 m) and (d) (235 m).

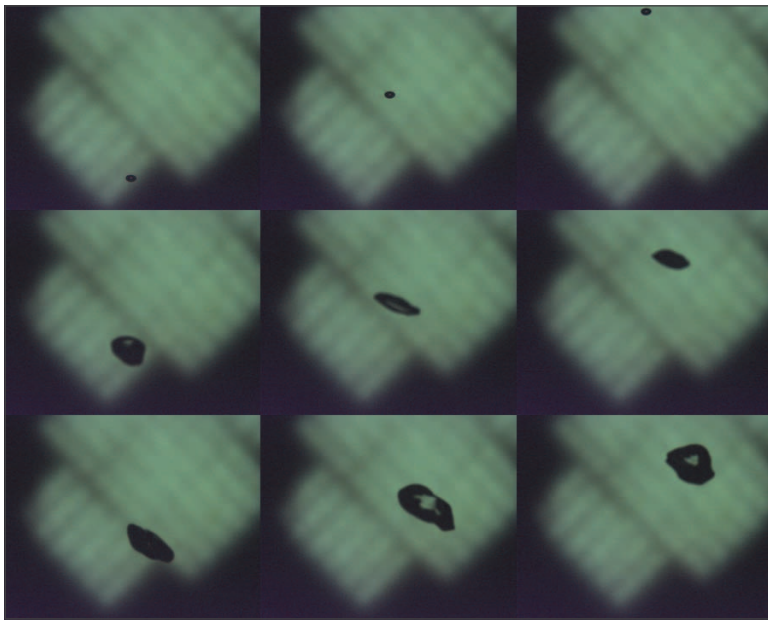

Figure 20-2. Non-spherical bubbles imaged—both optically (shown here) and acoustically during tank experiments this winter.

ond paper on broadband scattering from individual oil droplets is undergoing a last round of minor revisions, and is anticipated to be published this summer/fall by JASA. A third paper analyzing field data collected at the Taylor Energy site (Figure 20-1), the location of a wrecked and leaking set of oil wells, has been wrapped up in terms of the thesis and is currently being pre-

pared for submission to a peer-review journal. In this work, estimates of the total flux of oil associated with the lower portion of the plume has been estimated (preliminary estimates range from 150-350 barrels per day, assuming the entire lower portion of the plume is oil).

Work associated with a BSEE/NSF funded experiment at the Coal Oil Point seep field, including an estimate of the current flux of gas and observations of oil, has now been published in JGR-Oceans: Padilla, A.M., Loranger, S., Kinnaman, F. S., Valentine, D.L., and Weber, T.C. (2019). Modern Assessment of Natural Hydrocarbon Gas Flux at the Coal Oil Point Seep Field, Santa Barbara, California. *Journal of Geophysical Research: Oceans*.

One of the important aspects of this work is refining our acoustic inversions for bubble/droplet mass flux by taking into

account the non-sphericity and/or hydrate coatings. Alexandra Padilla has conducted a set of tank experiments examining broadband backscatter (10-40 kHz) from non-spherical bubbles (Figure 20-2). These acoustic observations are being compared to standardly-used models, as shown in Figure 20-3, to help identify model limitations and assess possible errors in mass flux estimates that use them.

With the benefit of an NSF GRIP internship, Padilla has been working with Carolyn Ruppel and Bill Waite (USGS) to obtain acoustic backscatter measurements of hydrate-coated Xenon bubbles in a bubble trap. The bubble trap is a flow-loop device (Figure 20-4) that utilizes techniques for trapping bubbles developed at the Center, but has the capability of operating at much higher pressures and, accordingly, the ability to make hydrate. Tests of both bubble evolution over long times, and acoustic backscatter measurements from hydrate-coated bubbles, are being undertaken.

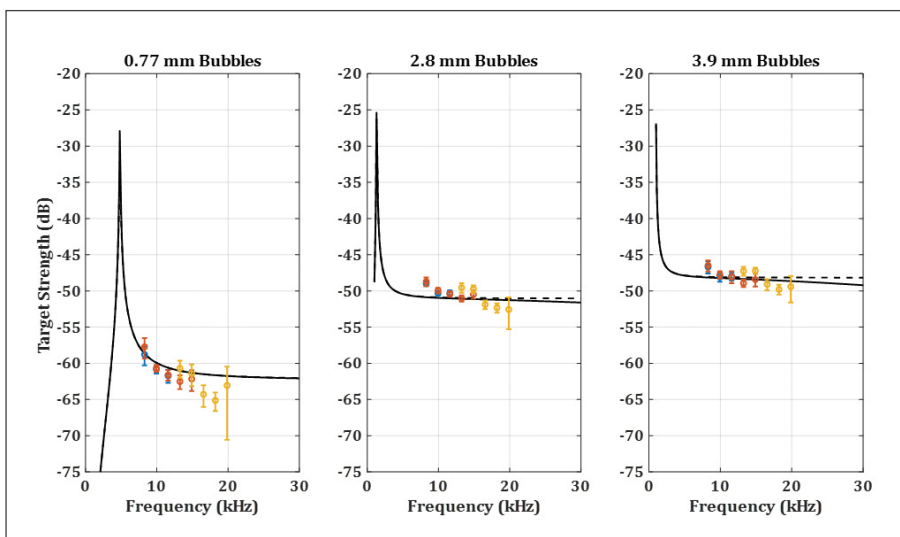

Figure 20-3. Target strength measurements from bubbles, such as those shown in Figure 20-2, in comparison with standardly used TS models. The data points and the vertical error bars represent the mean and the mean plus/minus the standard deviation of TS estimates obtained from a vertically-oriented echo sounder operating with LFM pulses of 8-13 kHz (blue), 8.05-16.1 kHz (red), and 12-20 kHz (yellow).



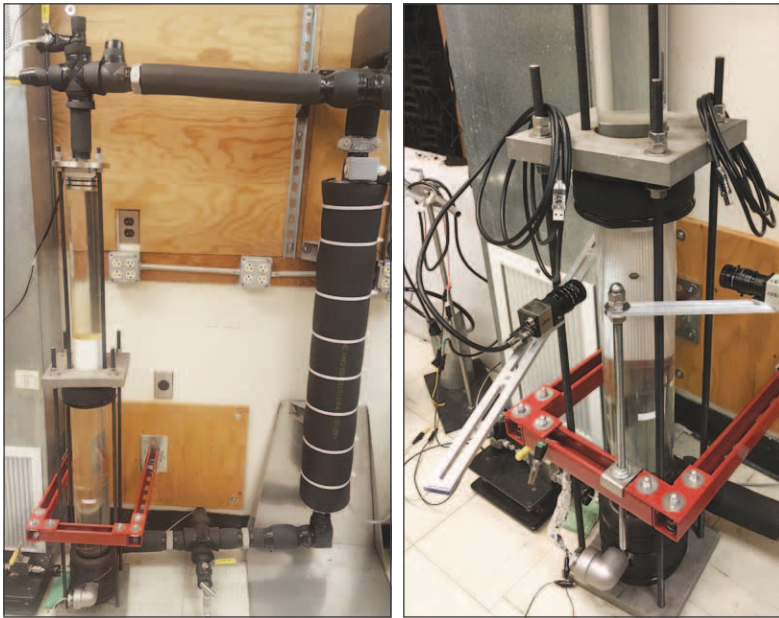

Figure 20-4. An image of the USGS flow loop device, used to examine hydrate-coated Xenon bubbles.

During this reporting period, graduate student Elizabeth Weidner continued research into the broadband acoustic discrimination and characterization of hydrate-coated bubbles in the Gulf of Mexico. Data were collected in early 2018 onboard the NOAA Ship *Okeanos Explorer* over the Biloxi Dome in the Northern Gulf of Mexico. During operations in the Biloxi Dome region, the *Okeanos Explorer* drifted over a seep site and individual bubbles were observed escaping from the seafloor and rising several hundreds of meters through the water column in the broadband acoustic data (Figure 20-5).

This study site sits well within the gas hydrate stability zone which requires high pressure and low temperature conditions. Laboratory experiments have shown that methane bubbles originating in the hydrate stability zone will grow a hydrate coating at the gas-water interface and ROV

observations made by Center researchers at Biloxi have verified the presence of hydrate shells on the bubbles rising through the water column. Hydrate coatings affect the mass transfer rate at the bubble-water interface, thereby influencing bubble fate; however, the formation and dissolution rate of hydrate coating is not well quantified. We hypothesize these bubbles are coated in gas hydrate shells for some portion of their upward journey through the water column. Successful isolation and extraction of the acoustic response of an individual bubble will provide the means to explore the effect of hydrate coating on acoustic scattering and bubble fate during rise.

The EK80 data collected during the cruise had a frequency range from 15-29 kHz and a usable bandwidth of approximately 10 kHz, which provides a vertical range resolution on the order of 7 cm, meaning that individual targets can be distinguish from each other,

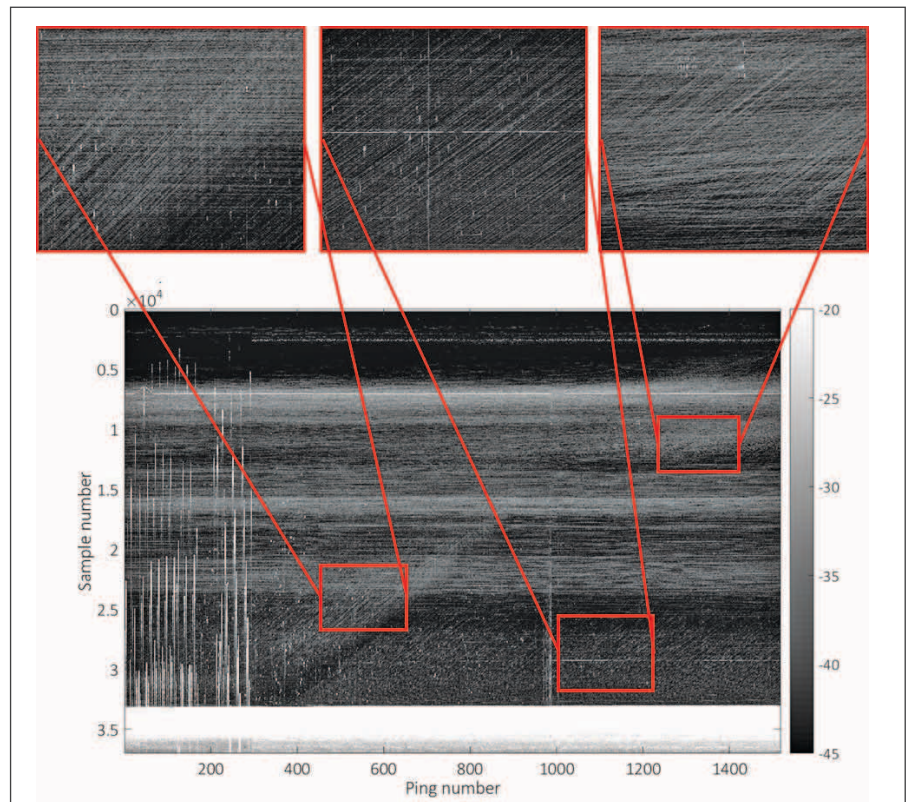

Figure 20-5. The match filtered EK80 broadband acoustic water column dataset from the EX1802 drift site. Inset panels show the diagonal traces of individual bubbles rising through the water column. Traces are distinguishable more than 1000 meters above the seafloor.



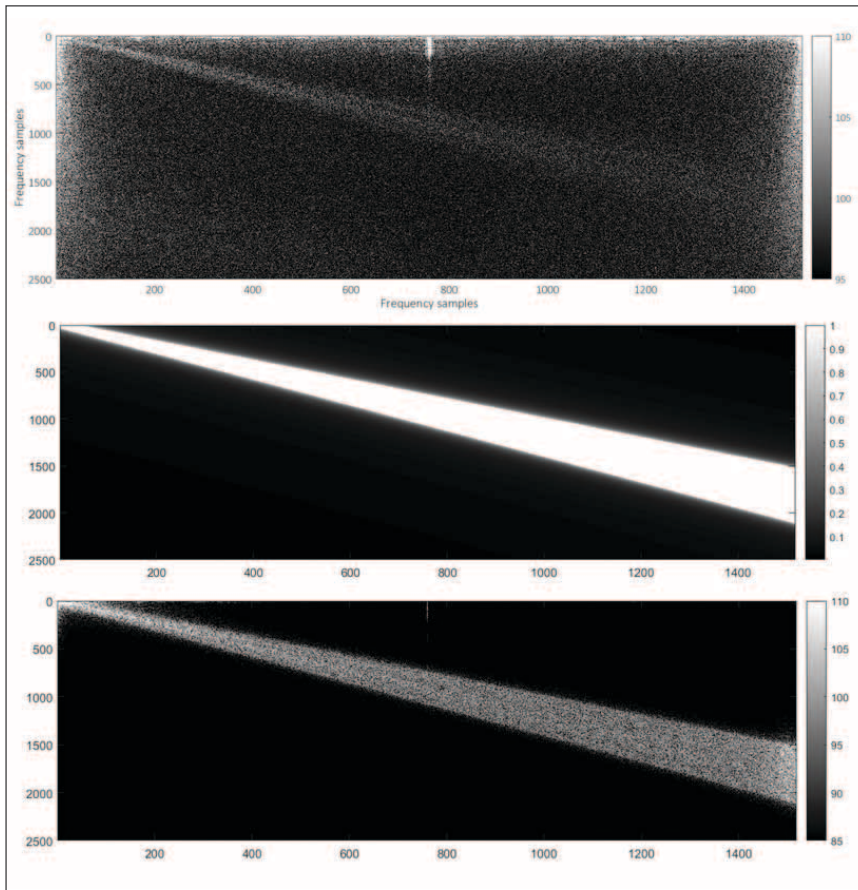

Figure 20-6. Two-dimensional Fourier transform of the Biloxi Dome data (top panel), flat-top filter used to isolate the response of the bubbles (middle panel), and the result of the filtering process (bottom panel).

provided they are separated by a minimum of 7 cm. The data were parsed and match filtered using MATLAB scripts developed at the Center. Preliminary attempts to sample the individual bubble traces were not successful due to low signal-to-noise ratio (SNR); the algorithm used to detect the response of a bubble could not confidently identify a bubble rising ping-to-ping.

To reduce background noise, thereby improving the SNR, a spatial filter was applied to the dataset. First a two-dimensional Fourier Transform of the data was taken (Figure 20-6, top panel). In the spatial frequency domain, the bubble energy is isolated and concentrated in the diagonal band with a relatively constant spatial frequency ratio; variability in the ratio results from variable rise rate of individual bubbles. A flat-top filter, fitted to the region of bubble-related energy, was applied to the data to suppress energy everywhere but along the diagonal (Figure 20-6, middle panel) and the result shows the isolated energy from the bubble scatterers (Figure 20-6, bottom panel).

The inverse two-dimensional Fourier Transform of the filtered dataset was then taken and the resulting dataset can be seen in Figure 20-7, bottom panel. The individual traces in the filtered dataset are more distinct over a series of pings as compared to the original dataset (Figure 20-5).

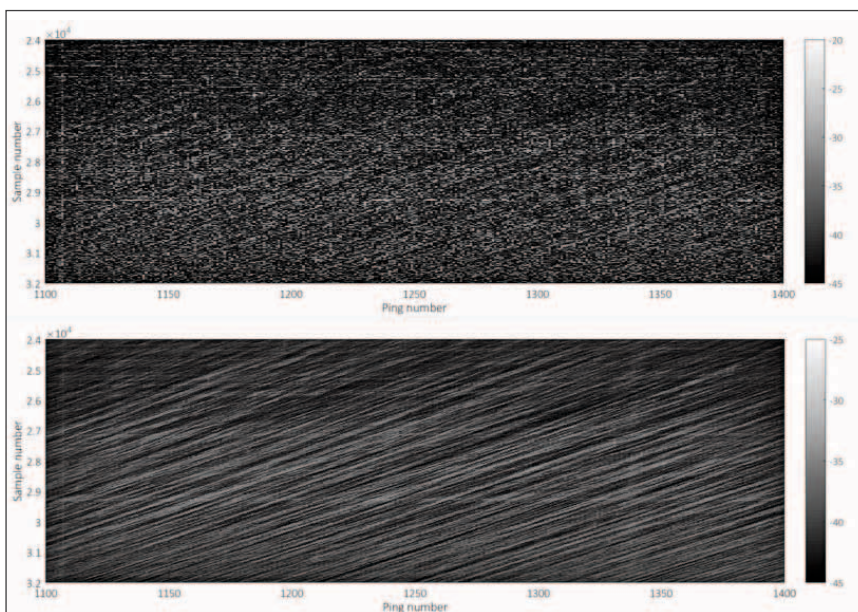

Figure 20-7. A subset of the original match filtered acoustic data (top panel) and the spatially filter dataset (bottom panel).

**TASK 21: Approaches to Identification of Marine Resources and Mineral Deposits:** *Develop techniques for combining high-resolution bathymetry, backscatter, and seismic data with ground-truth samples to identify potential marine mineral deposits, as well as collect baseline information needed for environmental evaluations.*

PI: **Larry Ward**

**Project: Approaches to Identification of Marine Resources and Mineral Deposits on New Hampshire Continental Shelf (with additional funding from BOEM)**

**JHC Participants:** Giuseppe Masetti, Paul Johnson, Michael Bogonko, Rachel Morrison, and Zachary McAvoy

**Additional Funding:** BOEM

The overarching goal of this task is to understand better how the tools used for hydrographic surveying can also be used to enhance or develop procedures, protocols, or methods for identifying potential marine mineral deposits (specifically, sand and gravel). Associated with this goal is the development of procedures and protocols using the same data sources to develop databases that can be used for environmental evaluations of whether marine resources are going to be exploited or protected. This includes high-resolution bathymetry and seafloor maps depicting major physiographic features (geoforms) and surficial sediments. Furthermore, as continued advancements in MBES bathymetry and backscatter technologies are made, new methods or algorithms to utilize the technology to directly identify sand and gravel substrates, as well as habitats, need to be developed.

Identifying and exploiting marine mineral resources, specifically sand and gravel, on continental shelves can be relatively routine in many environments. For example, along the Southeastern and Gulf of Mexico coasts of the United States (U.S.), where the continental shelf is relatively homogeneous with respect to morphologic features, sand and fine gravel are frequently found in nearshore shoals, paleochannels, or off river systems as deltaic deposits. However, locating and exploiting marine minerals on complex shelf environments that are characterized by numerous physiographic features (geoforms) such as outcropping bedrock, reef structures, or eroding glacial deposits (e.g., drumlins, moraines or eskers) is often more difficult. For example, continental shelves found in paraglacial (previously glaciated) environments (e.g., Gulf of Maine or the Pacific Northwest including Alaska) or at tectonic plate boundaries (entire U.S. West Coast) are far more complex with respect to the seafloor morphology and sediments. Here, sand and gravel deposits are often less abundant and harder to locate and exploit. In addition, the seafloor can change dramatically over relatively

short distances (10s to 100s of meters). Consequently, more robust approaches for mapping the surficial geology and identifying marine minerals are needed in complex continental shelf environments. Furthermore, because of the scale of new seafloor mapping initiatives, automated approaches are needed to assist and to some degree replace simply using technical experts and trained analysts to manually map the seafloor. This is a problem numerous mapping programs—both within the U.S. and throughout the world—are struggling to resolve.

Regardless of the depositional setting, identification and extraction of sand and gravel resources on the seafloor calls for an understanding of the surficial geology, as well as the shallow subsurface stratigraphy. This requires the seafloor morphology be known in order to identify features associated with sand and gravel deposits (essentially based on conceptual models). This is best addressed with high resolution multibeam echosounder (MBES) surveys. In addition, grain size and composition of the surficial sediment needs to be understood in sufficient detail over an aerial extent large enough to allow not only the sand and gravel resources to be characterized, but the surrounding region to be mapped as well. This is important for assessing potential impacts to the seafloor if extraction of the marine minerals is carried out (environmental studies). Although MBES backscatter is immensely helpful for assessing general seafloor characteristics (e.g., hardness or similar sediment types) and mapping sediment boundaries, ground truth is still needed. If a potential sand and gravel deposit shows promise as a resource from the surficial geology, then the shallow subsurface seismic stratigraphy must also be assessed. At a minimum, high resolution seismic reflection surveys are required to evaluate the shallow subsurface structure, the three-dimensional geometry, and boundaries. Finally, vibracores are needed to characterize the sand and gravel deposits.



The efforts on this task to date have been focused on trying to expand the role MBES can play in identifying potential sand and gravel resources and enhancing methods to evaluate the impact of extraction on the seafloor. The strength of MBES lies in its ability to map the bathymetry of the seafloor in great detail, aiding the identification of morphologic features likely associated with sand and gravel resources (i.e., shoals) and distinguishing changes in the composition of the seafloor illuminated by backscatter (i.e., changes in grain size or roughness). Over the last several years a systematic approach has been used to evaluate MBES for helping identify potential marine mineral resources, building on knowledge gained from earlier studies describing the surficial geology and sand deposits on the continental shelf off New Hampshire (NH). Especially important to this effort are the following: high resolution MBES surveys conducted by the Center's Hydrographic Field Course since 2003 (Earth Sciences/Ocean Engineering 972); relatively recent NOS MBES surveys in the Western Gulf of Maine (WGOM); a synthesis of the all of the available high-resolution MBES surveys conducted in the WGOM; an expansion of the high-resolution bathymetry and backscatter compilation to include the southern New England shelf and Long Island; a large and comprehensive geological and geophysical database of previous studies on the NH shelf and vicinity; and detailed seafloor surficial geology maps depicting geofoms (physiographic features) and surficial sediments over a ~3250 km<sup>2</sup> area off NH (originally developed with support from BOEM, but significantly upgraded by the Center).

In support of this task we have created a compilation of bathymetry and backscatter in the western Gulf of Maine, (WGOM Bathymetry and Backscatter Synthesis—see 2015 Progress Report). Subsequently, the high-resolution bathymetry and its derivatives and partial backscatter coverage (of varying quality), along with a comprehensive review and synthesis of available subbottom reflection profiles, surficial databases and vibracores, were brought into ArcGIS and used to develop surficial geology maps (geofoms and sediments) (see 2016 Progress Report) and a first order description of sand and gravel deposits on the NH continental shelf (developed for BOEM). These maps are the highest quality seafloor surficial geology maps available for the continental shelf off NH (which recently were updated and improved).

Development of these products, especially the surficial geology maps, was extremely labor inten-

sive, needed extensive ground truth, and was largely based on "expert opinion." It was clear that the way forward for the development of the surficial geology maps depicting geofoms and sediments was to develop innovative, reproducible, less labor-intensive methods of evaluating and mapping the seafloor using remote sensing techniques centered on acoustics, specifically multibeam echosounder (MBES) surveys.

QPS Fledermaus Geocoder Toolbox (FMGT) Angular Range Analysis (ARA) was evaluated using the Center's Hydrographic Field Course MBES surveys. The goal was to assess the ability of ARA to predict the surficial sediment class based solely on backscatter in extremely complex seafloors such as the NH shelf. The results of the ARA were inconsistent with the surficial geology maps developed earlier and accompanying ground truth and did not show promise as a path forward (see 2017 Progress Report). This was attributed, in part, to the complexity of the seafloor with bottom types changing between bedrock, gravel, sand or mud over very short distances. As a result, a MBES starboard or port swath often covered multiple bottom types within a patch. Therefore, the seafloor needs to be segmented prior to use of ARA or other algorithms, allowing themes or similar approaches to be used. It was concluded that at this time the strength in using backscatter lies in identifying changes in the bottom sediment and boundaries, which is crucial to seafloor mapping. The use of backscatter for inversion studies will be revisited in the future if warranted as equipment and processing algorithms advance.

To further the ability to test machine-based algorithms and enhance surficial geology mapping of the NH shelf, a major field campaign was conducted in 2016-2017 to obtain accurately positioned bottom video, photographs, and sediment samples to complement available high resolution MBES surveys (see 2018 Progress Report; also updated here). The sampling focused on the area where MBES surveys were available including the Center's Hydrographic Field Course and the recent NOS surveys.

Most recently, a new algorithm (BRESS) developed at the Center was applied to selected MBES surveys on the NH shelf to evaluate its potential as an aid in mapping the seafloor morphology and surficial sediments in complex areas (see 2018 Progress Report). During 2019, this effort was continued and is described below.

**Evaluation of BRESS**

BRESS (Bathymetry- and Reflectance-Based Approach for Seafloor Segmentation) is an automated approach to define landforms and segment the seafloor into homogeneous areas based on co-located MBES bathymetry and backscatter. The algorithm, developed at the Center (Masetti et al., 2018), utilizes high resolution bathymetry to divide the seafloor into a limited number of contiguous areas of similar morphology (landforms) that constitute an element of, or in some cases, an entire physiographic feature or geoform. Subsequently, the features or landforms are segmented or joined based on acoustic reflectivity, resulting in dividing the seafloor into homogeneous areas with similar morphology and backscatter. The strength of BRESS is the ability to define landforms on the seafloor without operator bias. BRESS defines landforms using a limited number of parameters (types of landforms to be identified, size of the search annulus and flatness angle) and the seafloor bathymetry. Thus, there is no bias in interpretations, enhancing consistency in mapping (see Task 18).

Previously, the BRESS algorithm was applied to eight of the Center’s Hydrographic Field Course MBES surveys conducted on the continental shelf off NH. The results of the BRESS “landform” analysis were promising and proved helpful in mapping physiographic features on the seafloor. The BRESS “segmentation” analysis successfully identified larger, uniform areas of the seafloor that were composed of similar size sediment. However, in more complex areas the results were more ambiguous and need further evaluation. The ability of BRESS to segment the seafloor into uniform seafloor types and subsequently run inversion studies was not pursued as the appropriate approach is not clear. Although this was one of the original objectives of utilizing the BRESS algorithm to help map seafloor sediments, more advances need to be made before this becomes operational.

During the present reporting period, the BRESS “landform” algorithm was applied to NOS MBES surveys in the WGOM which have excellent bathymetry but lack high quality reflectivity. The results

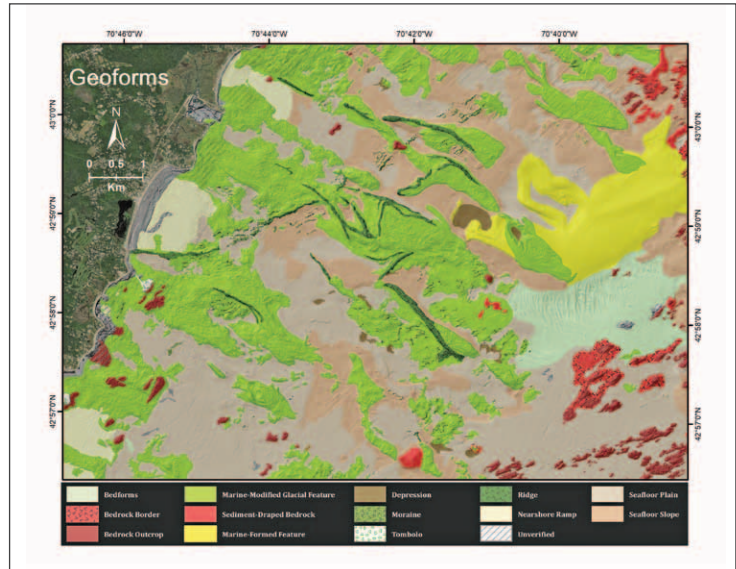

Figure 21-1. Surficial geology map of the nearshore continental shelf landward of the Isles of Shoals, NH showing the major geoforms. The seafloor is characterized by eroded glacial features (leaving behind megaclast deposits) and seafloor plains. The BRESS landform analysis of the same area is shown in Figure 21-2. Marine-modified glacial features are shown in green, marine formed features in yellow, seafloor plains in beige, depressions in brown, bedrock outcrops in red, nearshore ramps in ivory, and bedform fields in mint green. Dark grey areas are unmapped.

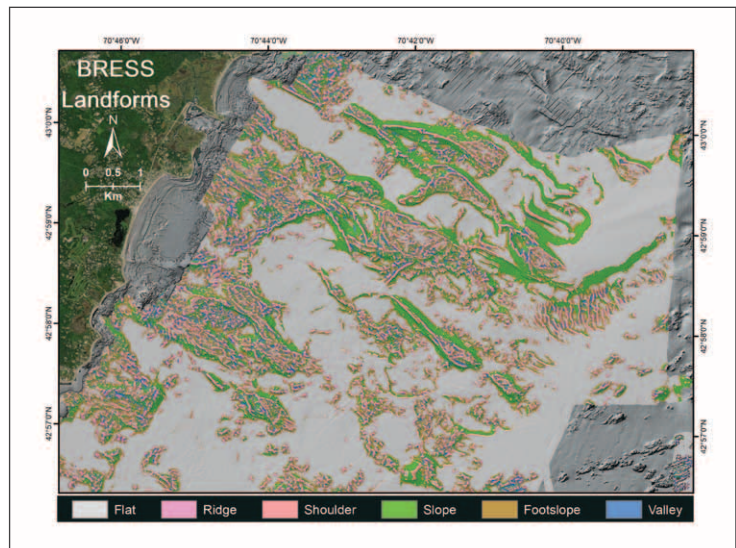

Figure 21-2. BRESS landform analysis of the nearshore shelf landward of the Isles of Shoals, NH. Many of the details of the geoforms shown in Figure 21-1 are shown by the mapping of ridges, slopes, valleys, and flats. Dark grey areas are unmapped.

of the BRESS landform analysis using the NOS surveys gridded at 4m are very promising and compared well with updated surficial geology maps depicting major geoforms (Figures 21-1 to 21-2).



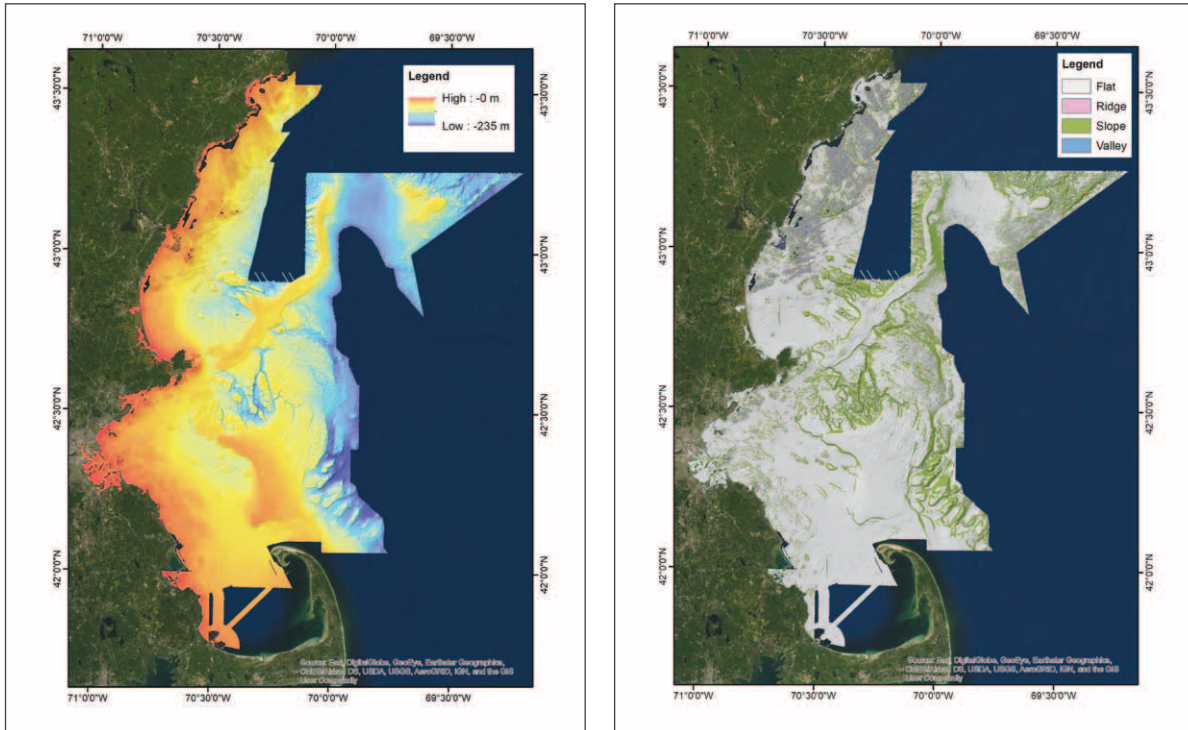

Figure 21-3. Western Gulf of Maine Bathymetry synthesis composed of MBES surveys gridded at 16 m (left panel). BRESS landform analysis of the bathymetry (right panel). Figures 21-4 and 21-5 are enlargements of the BRESS landform map.

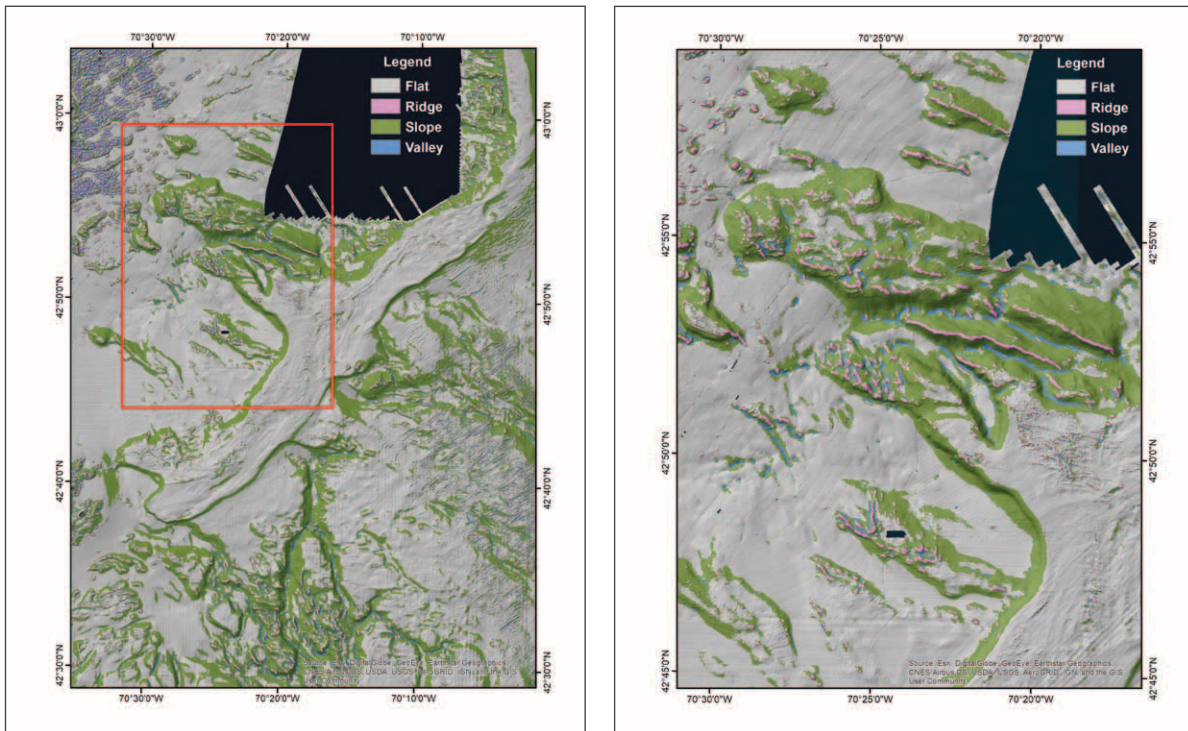

Figure 21-4. Enlargement of the BRESS landform analysis of the bathymetry shown in Figure 21-3 (left panel). The left panel above includes Jeffreys Ledge (running diagonally across figure), large drumline-like features to the northwest (red box) and subglacial drainage channels to the south. The right panel is an enlargement of the area outlined in red. Note the slopes and ridges are clearly defined on the glacial features.



Landforms composing elements of physiographic features or geofoms such as bedrock outcrops, large scale bedforms, or marine modified glacial features such as eroded drumlins, eskers, or De Geer moraines are well-defined and easily discernible in the landform analysis.

Subsequently, the entire WGOM Bathymetry Synthesis was gridded at 16 m and the BRESS “landform” analysis performed. Initial results indicate limitations imposed by the scale of the gridding and the size of the analysis element. Due to the coarser gridding and settings used for the BRESS analysis, many small-scale features observed in the earlier BRESS landform analysis (Center’s Hydrographic Field Course MBES surveys gridded at less than 2 m and the individual NOS surveys gridded at 4 m) were not identified. However, larger features interpreted as drumlins, large subglacial drainage channels or iceberg scours were clearly identified (Figures 21-3 and 21-4). Therefore, it appears that multiple gridding scales and resolutions are needed depending on the detail required versus the size of the area being mapped. However, more testing of the BRESS algorithm is needed before its full potential can be determined.

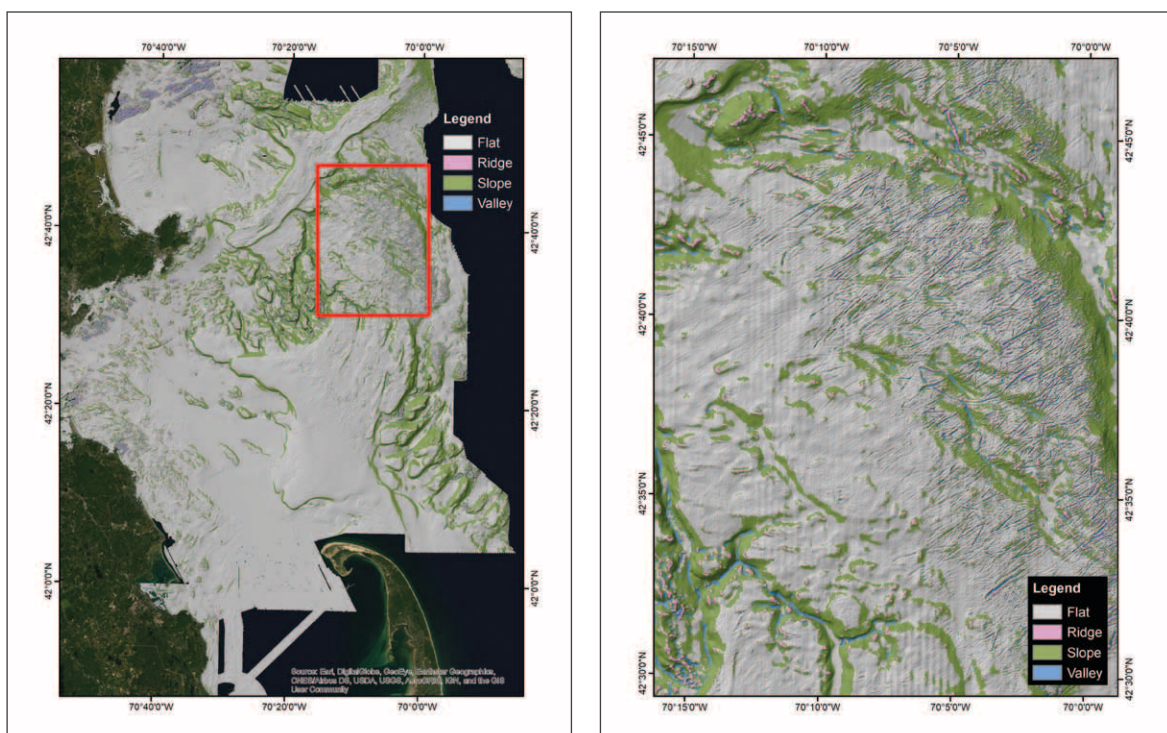

Figure 21-5. Enlargement of the BRESS landform analysis of the bathymetry shown in Figure 21-3. Extensive iceberg scours are clearly shown between Stellwagon Bank and south of Jeffreys Ledge (red box in the left panel). The iceberg scours appear as valley features (blue lines) in the enlargement shown in the right panel.

## NH Shelf Database

The original mapping of the surficial geology of the continental shelf off NH largely relied on archived databases and recently available MBES surveys (by NOS and the Center’s Hydrographic Field Course). The archived database allowed the initial surficial geology and sand and gravel resource maps to be developed (largely funded by BOEM). However, the age of some of the samples and subbottom seismics (all analog records), and more importantly, positioning errors, limited their value as ground truth for testing new algorithms.

During late 2016 and 2017, thirteen one-day cruises were conducted on the NH continental shelf to obtain accurately located sediment samples and seafloor images to complement the present extensive bottom sediment database. The new sites specifically targeted areas where high-resolution MBES bathymetry existed or surficial features warranted further ground truth for algorithm evaluations (see 2018 Performance and Progress Report).

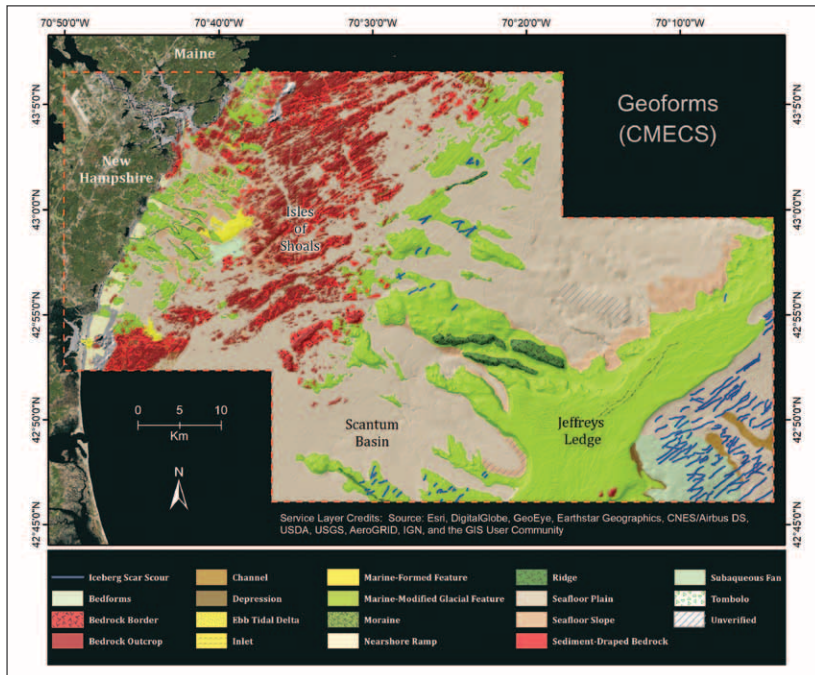

Figure 21-6. Surficial Geology map of the continental shelf off New Hampshire showing the major geofoms. The geofoms are based on a modification of the Coastal and Marine Ecological Classification Standard (CMECS). Marine-modified glacial features are shown in green, marine formed features in yellow, seafloor plains in beige, depressions in brown, bedrock outcrops in red, nearshore ramps in ivory, bedform fields in mint green and iceberg scours in blue. Dark grey areas are unmapped.

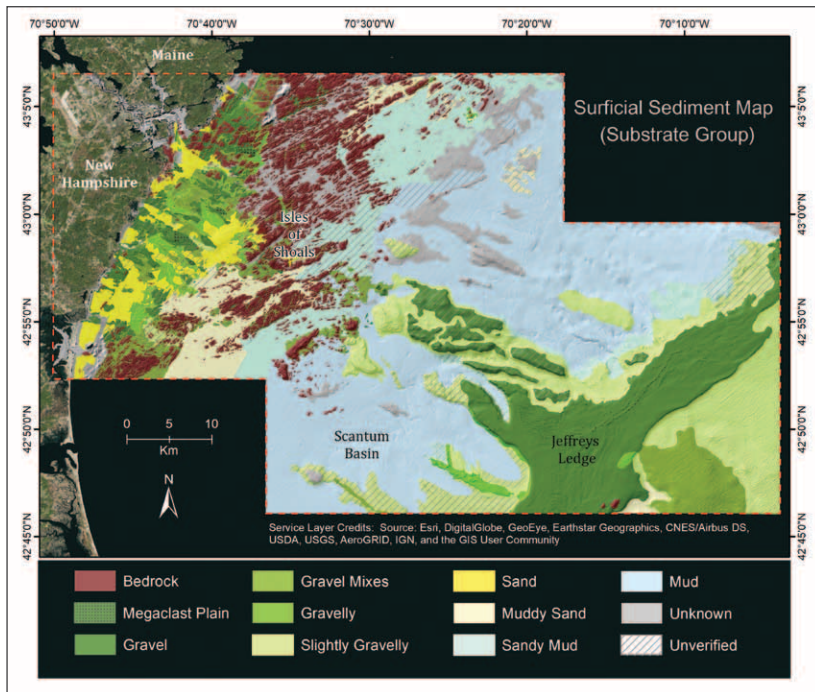

Figure 21-7. Surficial Geology map of the continental shelf off New Hampshire showing the surficial sediment distribution. The sediment substrate groups are based on the Coastal and Marine Ecological Classification Standard (CMECS)

In total, 151 stations were occupied, and seafloor video obtained. At 85 of these stations, two bottom sediment samples were normally collected. In addition, samples taken by the Center’s Hydrographic Field Course during the original surveys in 2012, 2014, and 2018 were also recovered and analyzed, providing ground truth at another 29 stations. Overall, a variety of bottom types were sampled. During the present reporting period, the additional samples collected during earlier Center’s Hydrographic Field Courses were processed, and the database updated and brought into a GIS platform for analysis and archiving. The database will be made available by web serving during the next reporting period.

**CMECS Mapping**

The high-resolution seafloor geology maps based on the Coastal and Marine Ecological Classification Standard (CMECS) that were originally produced in 2016 had multiple areas where additional ground truth was needed to either complete or verify the interpretation of the seafloor. Since high-resolution surficial geology maps of the NH shelf are fundamental to evaluating new algorithms, the maps were updated and improved using the ground truth obtained during the 2016-2017 NH Shelf Field Campaign (Figures 21-6 and 21-7). These maps, along with the ground truth from the field campaign are all archived in an interactive ArcGIS platform.



**Sub-Theme: SONAR**

**TASK 22: GeoCoder/ARA:** Renew efforts in the future development of ARA characterization algorithms, updating the code so that it uses stand-alone modern C++ libraries for mosaicking and seafloor characterization and allowing it to handle “theme” based characterization and incorporate of data from different sensors through the integration of backscatter processing libraries with HUDDL. **PI: Giuseppe Masetti**

**Project: GeoCoder/ARA – Seafloor Characterization**

**JHC Participants:** Michael Smith, Larry Mayer, Anthony Lyons, Tom Weber, and Larry Ward

**NOAA Participants:** Glen Rice (NOAA OCS HSTB), Mashkoor Malik (NOAA OER)

**Other Participants:** Alexandre Schimel (NIWA, New Zealand), Marc Roche (ECONOMIE, Belgium), Julian Le Deunf (SHOM, France), Margaret Dolan (NGU, Norway)

Most ocean mapping surveys collect seafloor reflectivity (backscatter) along with bathymetry. While the consistency of bathymetry processed by standard algorithms is well established, surprisingly large variability is observed between backscatter mosaics produced by different software packages from the same dataset. This severely limits the use of acoustic backscatter for quantitative analysis (e.g., monitoring seafloor change over time, or remote characterization of seafloor characteristics) and other commonly attempted tasks (e.g., merging mosaics from different origins).

Acoustic backscatter processing involves a complex sequence of steps, but since commercial software packages mainly provide end-results, comparisons between those results offer little insight into where in the workflow the differences are generated—commercial software packages tend to be a ‘black-box’ with only a few user-defined parameters. This can be seen as an advantage, making these technologies available to a large community, but it also engenders the potential for lack of data reproducibility. Currently, it is a challenge to ‘properly’ merge backscatter-based products from different vendors (sometimes even from the same vendor given the lack of metadata). The relevant differences observed among mosaics created from the same dataset with different software is a serious detriment to the use of acoustic backscatter for quantitative analysis and seafloor change monitoring.

Following the recommendation of a recently concluded Backscatter Working Group (BSWG) report stating that “initiatives promoting comparative tests on common data sets should be encouraged [...],” Giuseppe Masetti joined the Backscatter Software Inter-comparison Project (BSIP) that was launched in May 2018 in an attempt to understand the source(s) of inconsistency between the different software processing results. The group has invited willing software developers to discuss this framework and collectively adopt a list of intermediate processing steps and corrections.

A small dataset consisting of various seafloor types surveyed with the same multibeam sonar system, using constant acquisition settings and sea conditions, was provided to the software developers to generate

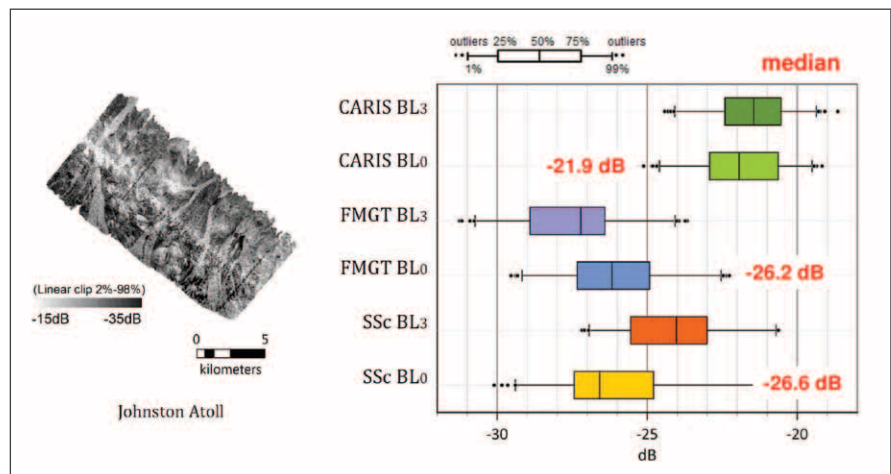

Figure 22-1. Results of a preliminary study that compares the mosaics created using different popular applications and options. The survey data were collected with a Kongsberg EM 302. BL0 represents the backscatter values retrieved from the raw data file; BL3 is the value obtained after all the corrections have been applied (before mosaicking). Intermediate processing stages have provided insights into differences between software outputs. In particular, the differences in BL0 values were not anticipated.



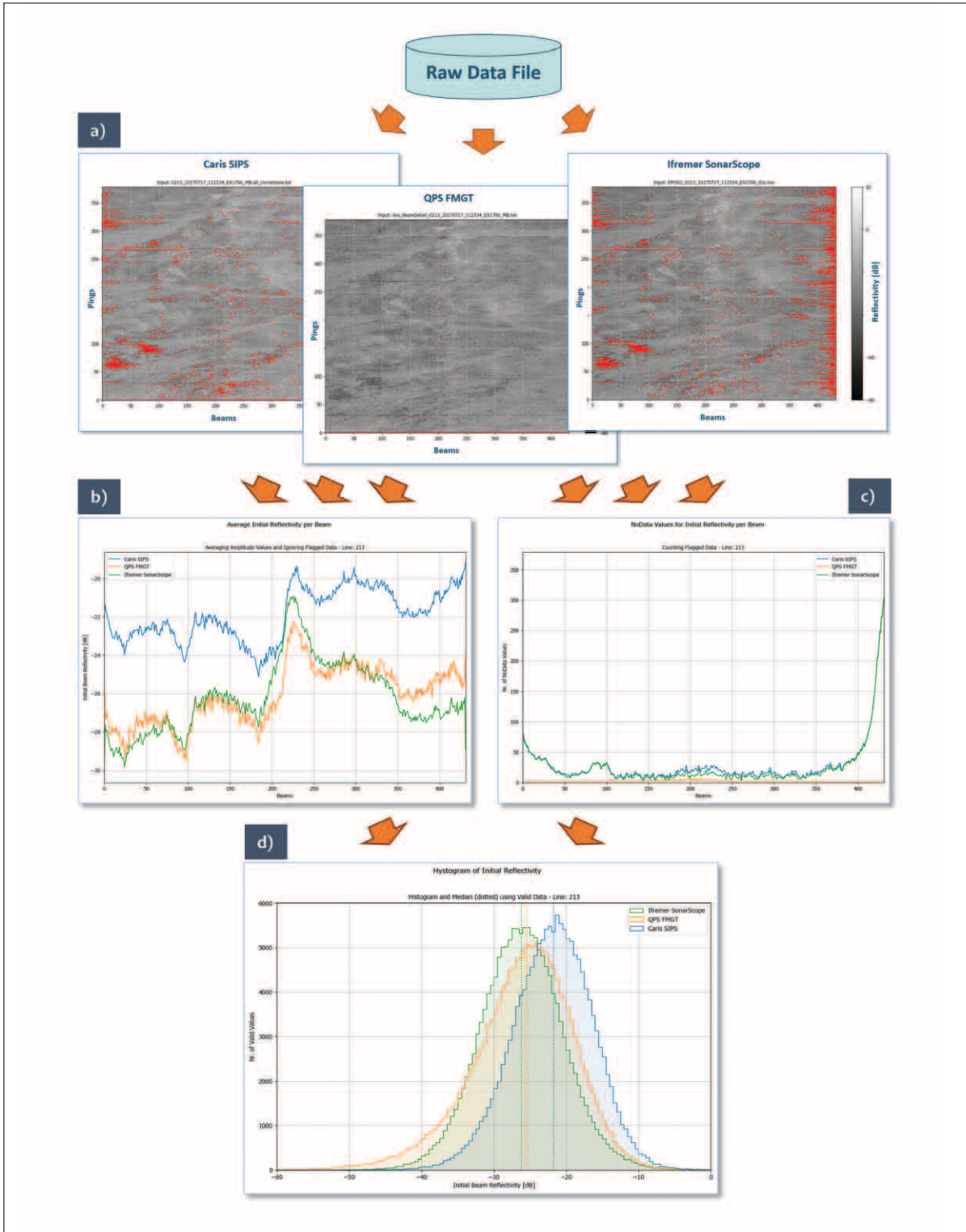

Figure 22-2. Pane 'a' shows the initial reflectivity values calculated by three software packages (and retrieved from the same raw data file) in a ping-beam geometry. Pane 'b' plots, for each package, the average value per beam across the whole survey line. Similarly, pane 'c' displays the number of no data values per beam. Finally, pane 'd' compares the resulting histograms for the three software packages highlighting how the resulting statistical characteristics starts to diverge since the very first processing step.

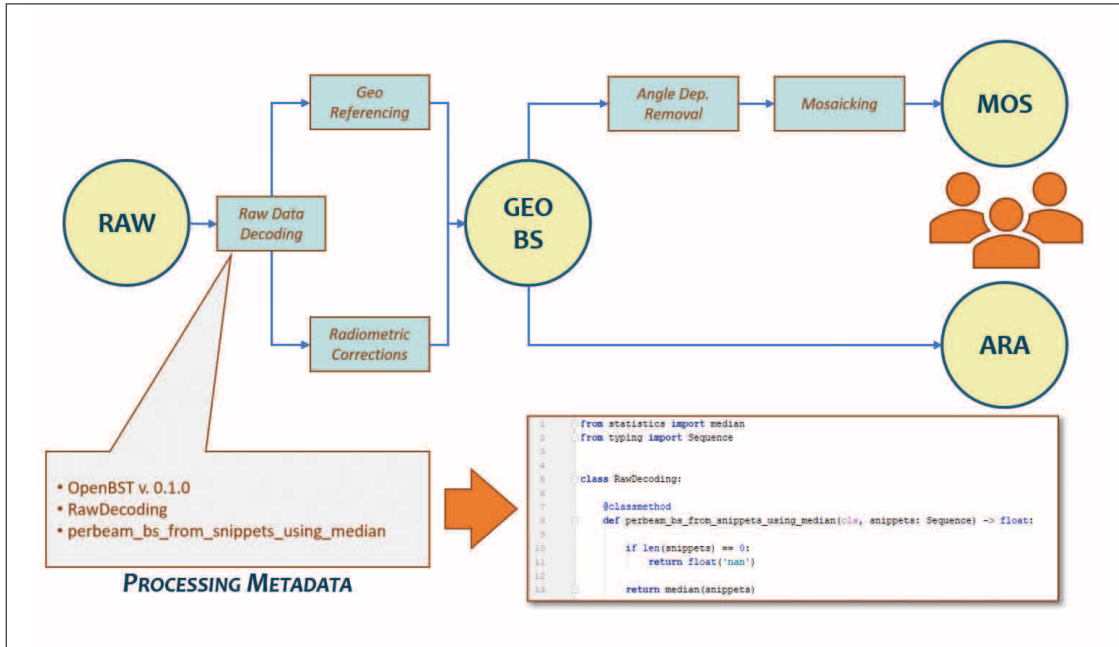

Figure 22-3. The backscatter users usually work with the backscatter mosaics and/or the angular response curves. These products are at the end of the processing workflow (i.e., after raw data decoding, geo-referencing, application of radiometric corrections), thus far from the initial data input. As such, it is difficult to identify where divergence occurs, thus the software processing workflow appears like a black box to the final users. For each processing step, OpenBST adds a processing metadata entry providing information about which library release and which method was adopted. This solution uniquely identifies the processing operation.

intermediate processing results. To date, the developers of five software packages (CARIS SIPS, Hypack, MB System, QPS FMGT, and SonarScope) have expressed their interest in collaborating on this project. Preliminary BSIP results have shown that each processing algorithm tends to adopt a distinct, unique workflow; this causes large disagreements even in the initial per-beam reflectivity values resulting from

differences in basic operations such as snippet averaging and evaluation of flagged beams (Figure 22-1). Such artificial variability in the currently generated backscatter products heavily limits their use for quantitative analysis (e.g., monitoring seafloor change over time), severely impacts the statistical distribution of the collected data, and precludes their merging into larger mosaics. These results have been recently

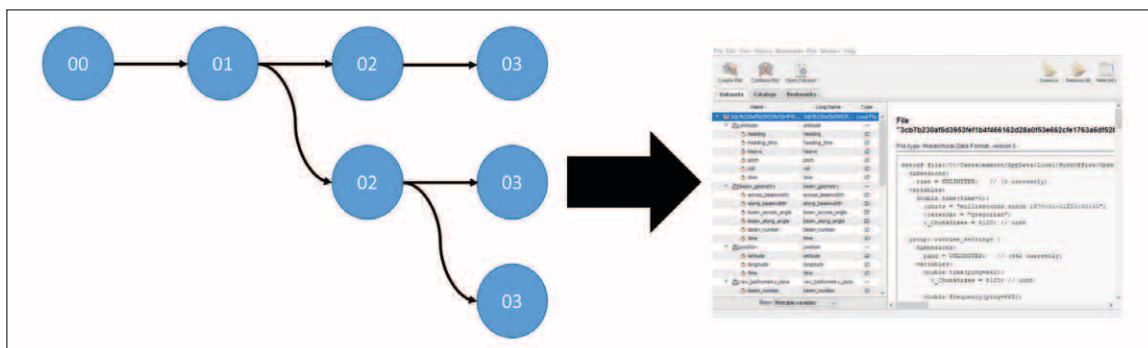

Figure 22-4. The processing workflow for OpenBST follows a directed acyclic graph (DAG) which leverages the NetCDF convention's self-descriptive and metadata coupling abilities to efficiently move through the backscatter processing workflow. On the left, the DAG diagram shows the results of a processing operation in the blue circle. On the right, a visualization of the sonar data in the NetCDF file obtained using NASA GISS' Panoply, a free software for netCDF file visualization.

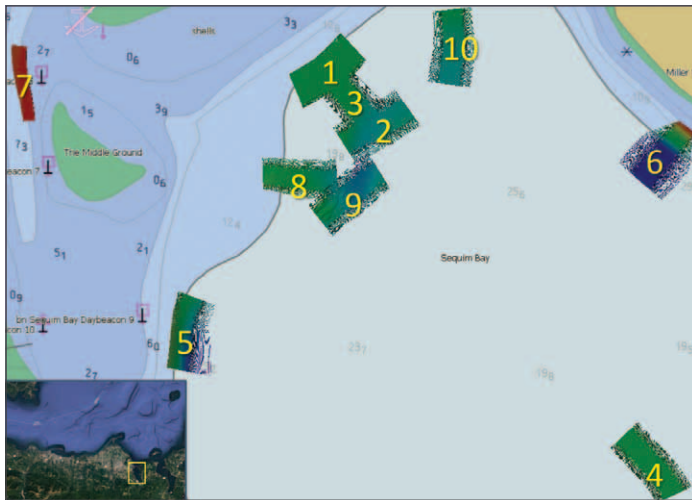

Figure 22-5. Bathymetric coverage of the Sequim Bay experiment, collected by the Applied Physics Laboratory of the University of Washington in March 2019. The data set utilized a Reson T50-P and collected data at 10 different sites (in yellow) of varying depth and different bottom types, utilizing a number of different frequencies. In addition to multibeam data, extensive ground truthing data was collected with the goal of verifying current physics-based inversion methods.

presented at the 2019 U.S. Hydrographic Conference and during the BSWG meeting at GeoHab 2019. All the current findings have been collected in an article, “Results from the First Phase of the Seafloor Backscatter Processing Software Inter-Comparison Project,” that has been accepted for publication by the MDPI’s GeoSciences journal. More information about the BSIP are available at <https://bswg.github.io/bsip>.

This situation is far from ideal (Figure 22-2), and resolution may require a shift from the closed-source software approach that has caused it. Thus, Masetti, Michael Smith, and Larry Mayer are collaborating with Ifremer and NOAA OCS/OER colleagues on the Open Backscatter Toolchain (OpenBST) project, with the overall goal of providing the community with an

open-source and metadata-rich modular implementation of a toolchain dedicated to acoustic backscatter processing (Figure 22-3). The long-term goal is not to create processing tools that would compete with available commercial solutions, but rather to create a set of open-source, community-vetted, reference algorithms usable by both developers and users for benchmarking their processing algorithms. The project was presented at the hydrographic community during the 2019 U.S. Hydrographic Conference.

In order to ease the access to OpenBST open-source code, the project is written in Python (a popular and free programming language) and is maintained on GitHub within the HydroOffice Framework. Two additional hallmarks of the project are its use of NetCDF files as a data storage and management system, and the use of Jupyter Notebooks as the interactive front end. The NetCDF convention is a very popular scientific data format that is self-descriptive, and easily allows for metadata coupling (Figure 22-4). This helps facilitate the sharing of data and the inspection of data with third-party software. As the point of interaction for the project user, Jupyter Notebooks are an intuitive and easy to use interface. They contain all the necessary information to interact with the program and can be extensively annotated by the user on the fly. Further, inline plotting utilities allow for the data to be quickly visualized.

### Field Data to Support the OpenBST

The Sequim Bay Experiment is a collaborative project stemming from the Seafloor Characterization Using Physics-based Inversion (SCUPI) workshop. Researchers at the Applied Physics Laboratory at the University of Washington (APL-UW), collected bathymetry

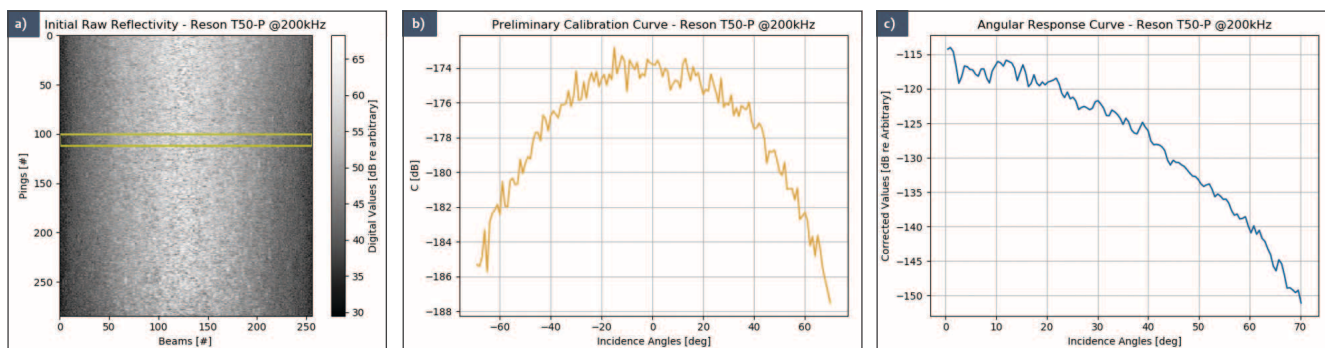

Figure 22-6. Example of the extraction of an angular response curve (pane ‘c’) from the original Reson s7k raw data (pane ‘a’), obtained after application of a preliminary calibration curve (pane ‘b’) and ensemble averaging over 12 pings (yellow area in pane ‘a’).



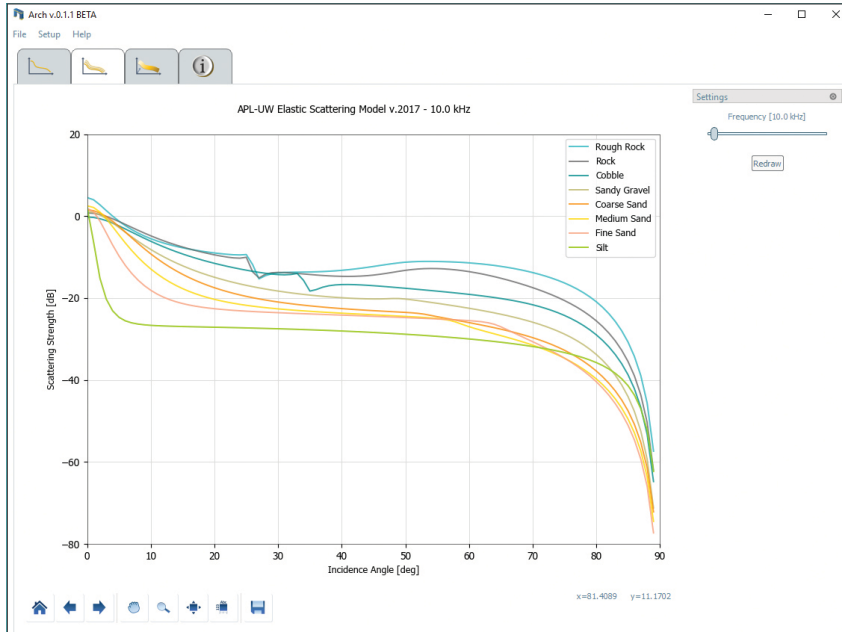

Figure 22-7. Example of model-based angular response curves (at 10 kHz) for several types of sediment, some of them supporting shear waves (i.e., rock).

and seafloor backscatter data using a Reson T50P Multibeam Echosounder (Figure 22-5). The dataset was augmented with an extensive ground truthing effort. Additionally, calibration of the Reson system was conducted by Tom Weber, Carlo Lanzoni, and Michael Smith at the Chase Ocean Lab (see Task 1). The Sequim Bay Experiment provides the OpenBST project an excellent opportunity to develop an open and transparent processing methodology for Reson multibeam echosounders and compare results against physics-based models and commercial software programs. Smith and Masetti are developing a proof of concept for such a methodology (Figure 22-6).

Based on the outcomes of an April 2018 workshop on physics-based seafloor characterization organized by Tony Lyons, the integration of the new APL-UW model developed by Darrel Jackson into the ARA code has continued. This model is the successor to the APL-UW TR9407 model and employs an improved roughness scattering approximation and a physical model for volume

scattering, along with the ability to treat seafloors that support shear waves (Figure 22-7). As such, Masetti and Lyons are evaluating its adoption to potentially improve the ARA output, and efforts are also underway to evaluate its potential for multi-spectral analysis (Figure 22-8).

Once artifacts and software- or hardware-created differences in backscatter values have been removed, a critical next step for automated seafloor characterization algorithms is to attempt to segment the seafloor into regions of common seafloor type. Typically, this is done either by looking at the morphology or the backscatter, but rarely are backscatter and morphology used simultaneously. To address this, Masetti, Mayer,

and Larry Ward are working on a project to automatically segment the seafloor into homogeneous areas through a combination of information from both and bathymetric observations (see Task 18).

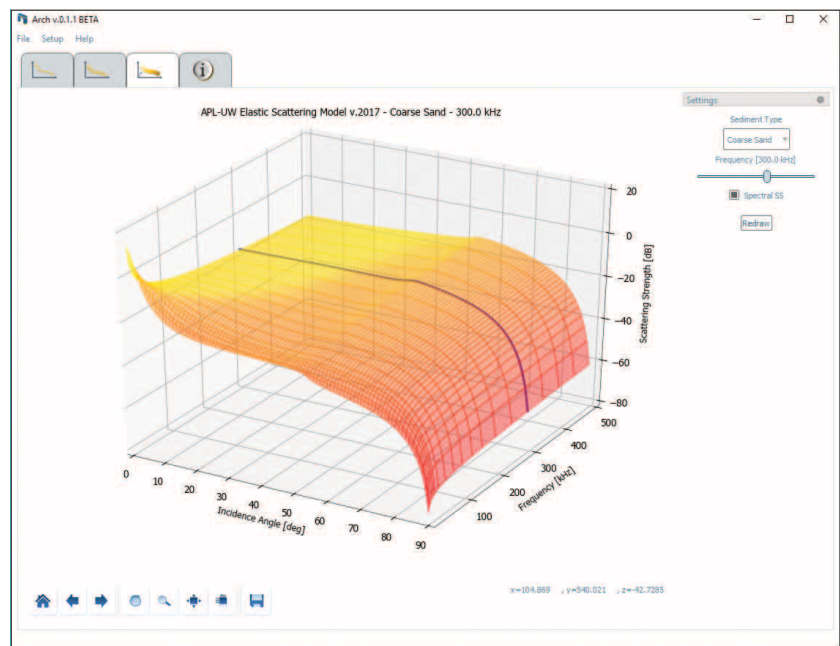

Figure 22-8. Example of model-based multispectral backscatter surface for a specific sediment type (i.e., coarse sand). The curve in blue corresponds to the angular response curve for coarse sand in Figure 22.6.

**TASK 24: Multi-frequency Seafloor Backscatter:** Undertake controlled experiments designed to understand the physical mechanism for seafloor backscatter at high frequencies (>100 kHz) commonly used on the shelf for mapping habitat, managing resources, etc. Explore the higher order statistics of backscatter (e.g., scintillation index) as potential aids to interpreting habitat, and to look at temporal changes in backscatter for a variety of substrates over a wide range of time scales. This effort includes the need for the collection of broadband, calibrated seafloor backscatter along with “ground-truth” measurements using stereo camera imagery, bottom grabs, and box cores (to examine potential contributors to volume reverberation). **PIs: John Hughes Clarke and Tom Weber**

**Project: Multi-Frequency Seafloor Backscatter**

**Other JHC Participants:** Ivan Guimaraes

**NOAA Collaborators:** Glen Rice and Sam Greenaway, HSTP

**Other Collaborators:** Anand Hiroji, USM; Dave Fabre and Rebecca Martinolich, U.S. Naval Oceanographic Office; Fabio Sacchetti and Vera Quinlan, Marine Institute, Galway, Ireland; Kjell Nilsen and Kjetil Jensen, Kongsberg Maritime; Lars Andersen and Jeff Condiotty, Simrad-KM

Seafloor characterization remains a core requirement for NOAA. Using the mono-spectral backscatter obtained from their current sonars, reasonable seafloor discrimination has been achieved. It is apparent however, that some seafloors that are strongly contrasting in physical character, do not show up as discrete using just a single scattering frequency. As a result, taking advantage of the wider band and multiple-multibeam now being installed on the NOAA OCS fleet (NOAA Ship *Thomas Jefferson* and NOAA Ship *Nancy Foster*), this task investigates the improved discrimination potential achievable by using multi-spectral backscatter.

In 2019, the main achievement was a broadband backscatter calibration experiment. Additionally, continued field acquisition of multi-spectral data is taking place on three platforms: R/V *Celtic Explorer*, USNS *Bowditch* and CSL *Heron* (Figure 24-1).

**Absolute Broadband Seabed Backscatter for Multibeam Beam-Pattern Calibration**

All multibeam sonars system suffer from uncalibrated combined transmit and receive beam patterns. Previously, for single frequency surveys using a single sonar, empirical calibration was attempted to remove the resultant overprint on the seabed mosaic. And for multi-vessel surveys, arbitrary platform to platform offsets were applied. None of these solutions, however, provide repeatable results and thus limit the value of backscatter mapping (see Task 22). Such problems are only compounded when multi-frequency systems are employed.

To get around this limitation, there has to be an absolute measure of the seabed backscatter strength to serve as a reference. This can be achieved by having an independently calibrated sonar that is mechanically rotated to provide backscatter strength measurements at all grazing angles. For multi-frequency systems, the same experiment has to be repeated for each frequency (Figure 24-2).



Figure 24-1. Showing the platforms used for active testing of multispectral backscatter by CCOM in the 2019 field season.

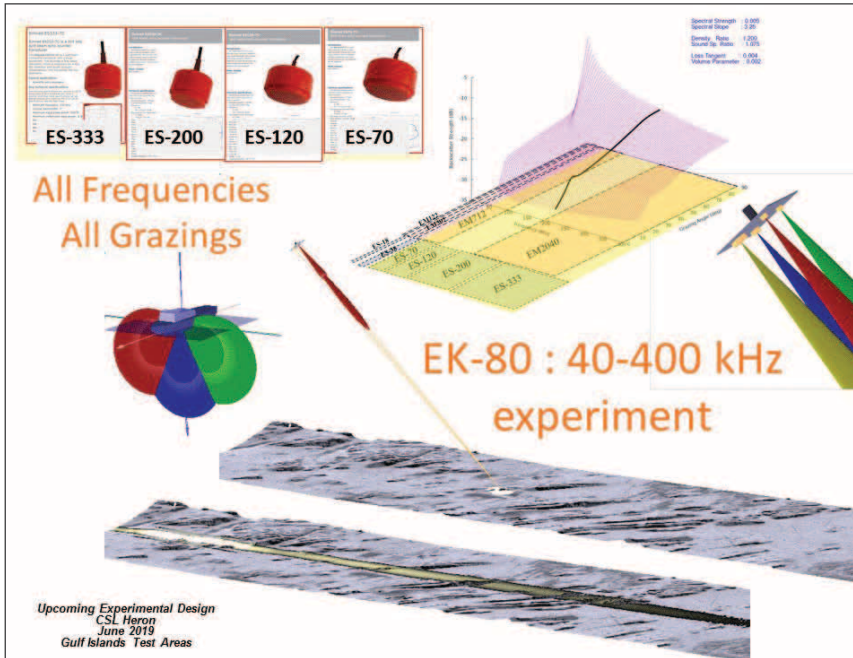

Figure 24-2. Showing the geometry of the multi-frequency calibrated seabed backscatter experiment.

To address this, a field experiment was designed in which four EK-80 split beam sonars were mounted on a plate suspended from the CSL Heron (Figure 24-3). The plate is equipped with a three-axis motion sensor so that it could be manually rotated over all grazing angles and azimuths. The four transducers (ES 70-120-200-333 kHz) all have overlapping bandwidths so that backscatter strengths could be measured continuously through the range from 40 to 400 kHz.

The field experiment was conducted at five test sites in British Columbia waters. The sites have widely different homogenous compositions (mud, muddy sand, sand, shell hash and gravel). At the same sites, EM2040P backscatter was acquired at 200-400 kHz and EM710 backscatter at 70-100 kHz. The experiment forms part of the master's thesis of Ivan Guimaraes.

As with previous years, the focus of the multi-frequency project con-

tinues to be on properly reducing large multi-spectral datasets collected using multi-beam survey systems. This year the following vessels have been used for the testing:

**R/V Celtic Explorer**  
EM302+EM1002+EM2040

The Irish Marine Institute is committed to systematic mapping of their entire continental shelf (10-200m depth). To that end, the R/V Celtic Explorer is currently operating three multibeam sonars at the same time—EM2040, EM1002 and EM302. The EM2040 meets the core bathymetric mapping requirement, but the other two sonars (optimized for the upper slope and deep ocean) provide a longer wavelength view of the surficial backscatter. At their invitation, we have been able to process the data and compare it to target ground-truth.

We now have three field seasons of data (Figure 24-4) and will soon have access to the 2019 data.

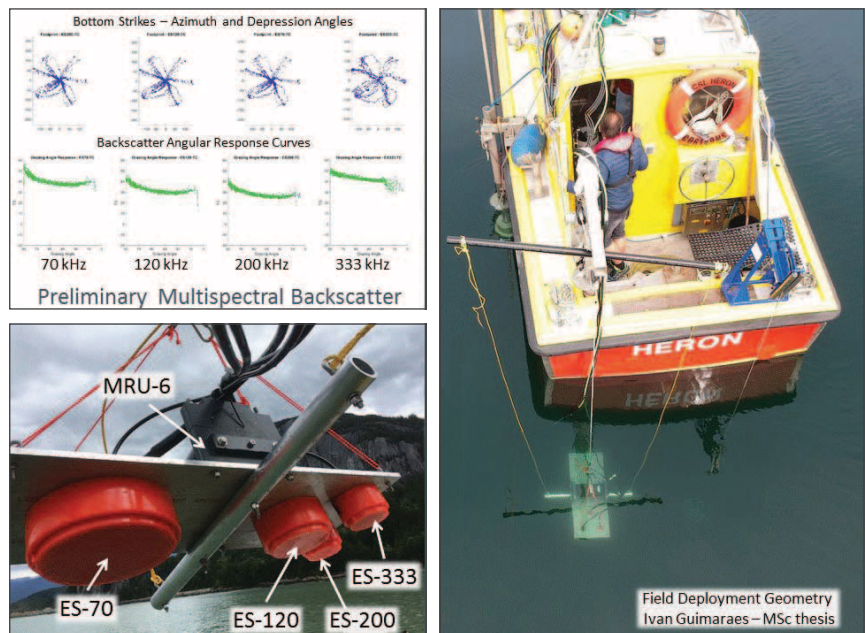

Figure 24-3. The 2019 field deployment logistics on the CSL Heron.



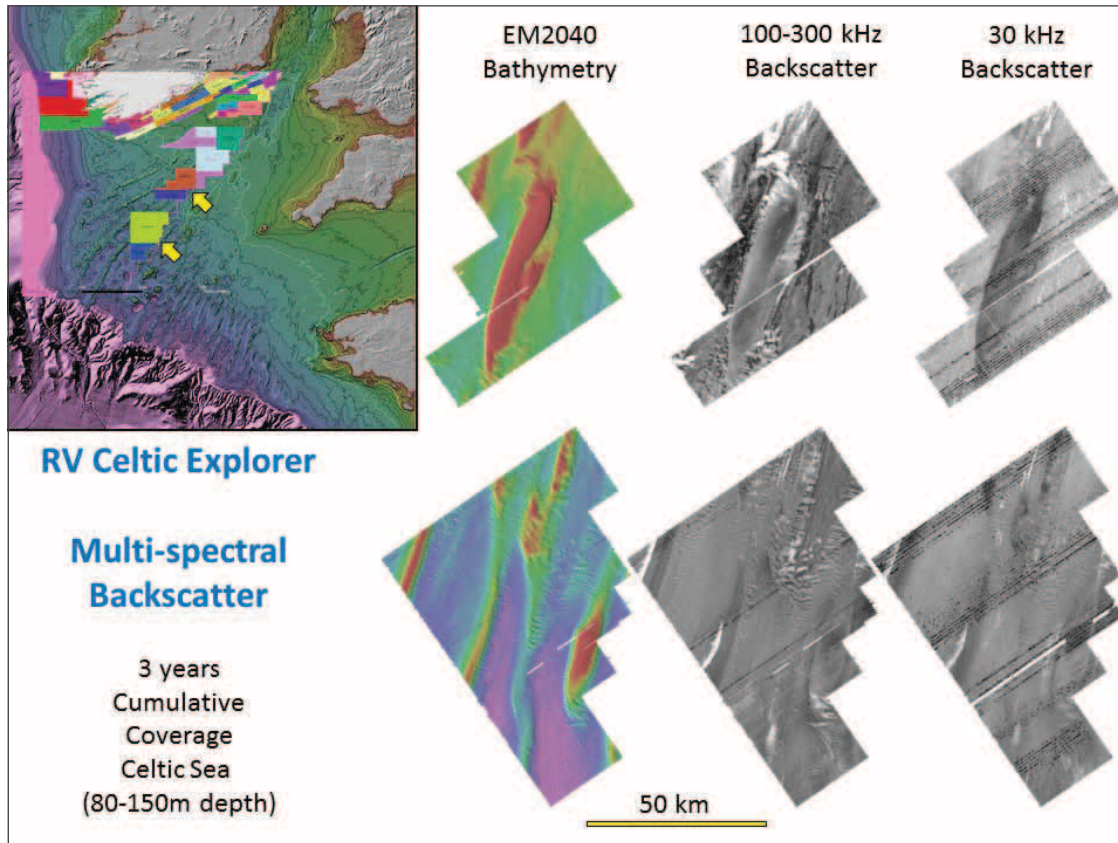

Figure 24-4. Cumulative Bi-spectral Backscatter coverage acquired by R/V *Celtic Explorer* in the Celtic Sea south of Ireland between 2016 and 2018.

**NAVOCEANO TAGS-60 Class**  
EM122+EM712+EM2040

The original multispectral experiments using a paired EM2040 and EM710 were conducted by Hughes Clarke on the USNS *Mary Sears* in 2012. Based in part on those results, with the latest cycle of sonar system upgrades, all six of the TAGS-60 class vessels will be getting a gondola-mounted EM2040 to complement their EM710 (now upgraded to an EM712). They are thus going to be equipped for routine multispectral data acquisition on continental shelf depths.

As part of a long-standing collaboration between Hughes Clarke and The U.S. Naval Oceanographic Office, a new set of multispectral experiments are being conducted. These included acquiring data from 12 to 400 kHz over standard test ranges. Their configuration is near identical to that on the NOAA Ships *Thomas Jefferson* and *Nancy Foster*. There thus are likely to be many benefits and efficiencies to be gained by comparing and contrasting results and approaches to routine multispectral backscatter collection and processing by NAVOCEANO and NOAA

**CSL Heron**  
EM710 and EM2040P

Following on from the first (2014) multispectral tests on the CSL *Heron* using her EM710 and an EM2040C, the same locations off Sidney, BC were occupied in the 2018 summer using an EM2040P. Notably, bottom photography and seabed grain size samples are now available for all these experimental sites. In 2019, the same systems were again used in support of the calibrated backscatter experiment.

**TASK 27: Video Mosaics and Segmentation Techniques for Ground-Truthing Acoustic Studies:** *Generate geo-referenced and optically corrected imagery mosaics from video transects of the seafloor and use image analysis techniques to detect and segment the imagery into regions of common species assemblages using the homogeneity of color tone within a region.* PI: **Yuri Rzhanov**

**Project: Video Mosaics and Segmentation Techniques for Ground-Truthing Acoustic Studies**

**Other JHC Participants:** Yuri Rzhanov, Igor Kozlov, Jennifer Dijkstra, and Kristen Mello

Due to the limited ability of light to propagate through water, the main effort at the Center focuses on the use of acoustic sensors to image the seafloor. Relatively low resolution of acoustic instruments and human inability to intuitively interpret acoustic backscatter limits the amount of crucial information on seafloor character (e.g., roughness and composition) that we can obtain. Thus, in developing approaches for using the acoustic sensors to derive important information about the seafloor, we need to be able to know the “ground-truth.” This information can be obtained by grab sampling or imaging the seafloor by optical means. Both approaches have pros and cons. Grab sampling is slow and spatially sparse. Conventional imaging does not provide information about the sub-surface components of the seafloor. However, its non-invasiveness, low cost and ability to image quickly large areas, makes it an attractive technique for providing ground-truthing information for our acoustic sensors and models.

Several directions have been chosen to utilize optical imagery for marine habitat classification. Construction of large-scale photo mosaics is now considered a well-researched (solved) problem. The most reliable information about habitats is extracted from 3D reconstructions. In the last three years the Center has developed a simulation framework for 3D reconstruction from imagery taking into account refractive effects and conducted a comprehensive analysis of optimality of conditions for optical data acquisition underwater. This research is also considered finished and is ready to be applied in the field. Several projects are currently underway to explore the limits of using optical data as ground-truth for our acoustic and habitat studies:

### 3D Reconstruction and Accuracy Estimation in the Presence of Refraction

**JHC Participants:** Yuri Rzhanov, Igor Kozlov, Jennifer Dijkstra, and Kristen Mello

The research is considered finished and is ready for application in field conditions. This year the Center conducted several numerical experiments to quantify the importance of effects of refraction that occur due to different speed of light in air, housing material, and water. Each particular setup leads to different error estimates that suggests the necessity to simulate specific cameras’ setup prior to data acquisition. In particular, Figure 27-1 demonstrates how the number of images of a calibration object affects accuracy of determination of such an important refractive parameter as a distance between camera focal point and first refractive interface. Monte-Carlo simulations were run 1000 times for each number of calibration object poses.

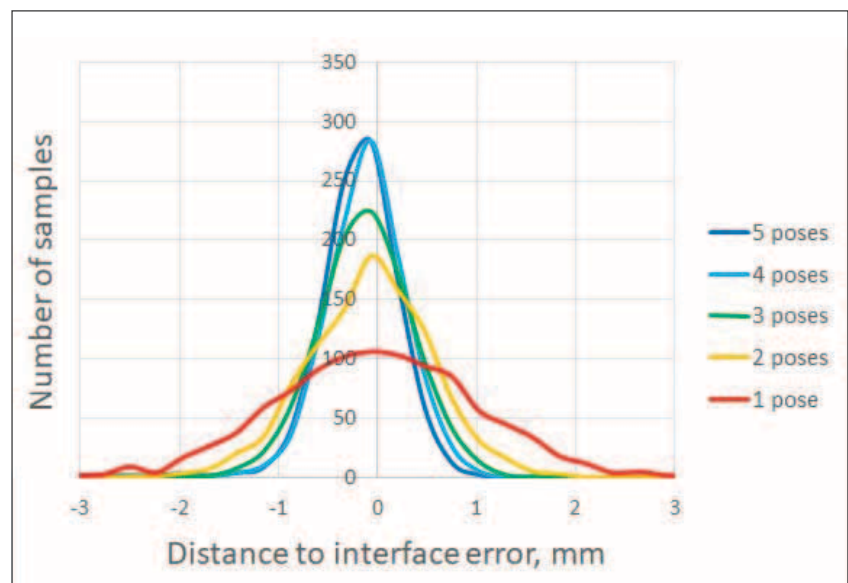

Figure 27-1. Distribution of errors of the refractive parameter for different number of images of a calibration object.



Figure 27-2. ESPROS evaluation kit with IR light sources.

**Collection of Bathymetric Measurements on Sub-Centimeter Scale**

JHC/CCOM Participants: Yuri Rzhanov and Carlo Lanzoni

Short-range depth measurement can be performed using Time-of-Flight (TOF) sensors similar to widely known Kinect-2. Unfortunately, all currently developed TOF sensors use light in infrared part of spectrum that is strongly absorbed in water. Substitution of the IR light source with a green or blue laser would allow for reliable underwater sensing with ranges up to five meters and sub-centimeter resolution. The main advantage of TOF sensors is that they simultaneously acquire a two dimensional array of measurements—frame pseudo-imagery, unlike a conventional lidar. Redundancy in measurements due to frames’ overlap permits to eliminate inaccuracies in platform positioning and apply Simultaneous Localization and Mapping (SLAM) techniques to improve a digital elevation model. We are investigating the use of green laser for TOF studies, specifically using an epc660 evaluation kit produced by ESPROS Photonics Corporation (Figure 27-2) in conjunction with a powerful green laser as an illumination source.

**Classification of Benthic Imagery Using Traditional Techniques and Machine Learning**

JHC/CCOM Participants: Yuri Rzhanov, Jennifer Dijkstra, Kim Lowell, and Jordan Pierce

Marine habitat classification plays a crucial role in investigation of anthropogenic processes in the Earth’s oceans, seas, and lakes. Coral bleaching and propagation of invasive species are examples of results of human activity that need to be monitored. Classical procedures for the collection of statistics for marine species consist of random positioning of a rectangular frame (usually quadrat) on the seafloor, taking a photo image of it, and manually annotating everything within a frame. The last step is the most time-consuming and may take more than 100 times longer than the image acquisition (including travel to and from the site and divers’ deployment). The most popular annotation method for seascapes is CPCe, where the annotator manually classifies a certain number of randomly distributed points within a quadrat. Unlike annotation of images for the presence or absence of well-defined fauna (starfish, scallops, lobsters, etc.) or man-made objects (plastic/glass bottles, cans, etc.), automation of annotation of images of colonies (like corals or bacterial mats) is significantly more difficult, as it cannot be achieved by extraction of distinct features but requires a recognition of textures. Texture is an intuitively clear concept that is difficult to formal-

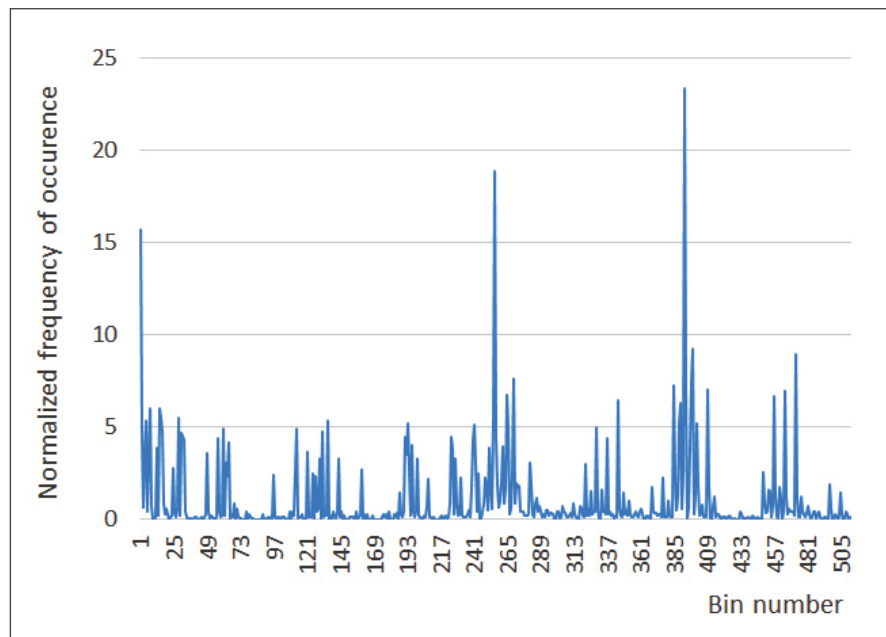

Figure 27-3. Typical LBP histogram with 512 bins.



ize in imaging. It is an important visual cue and texture classification is a fundamental issue in computer vision essential for a very wide range of applications. Texture cannot refer to a single element like a pixel; rather it is a property of an image patch, which leaves open questions about the patch size and its homogeneity. Texture classification has been an active research topic for more than five decades, but has received renewed interest with the development of novel image processing techniques like deep learning. It has been lately demonstrated that convolutional neural networks (CNN) originally designed for recognition of specific objects are in fact extremely responsive to the presence of textures in the training sets of images.

Experiments with traditional textural descriptors such as local binary pattern (LBP) have been partially successful. In this approach, each texture is represented by a normalized histogram (Figure 27-3) with a predefined number of bins and classification is performed by calculation of certain distance (usually, Kullback-Leibler distance) between the histograms from an existing catalogue and a histogram calculated for an area being classified. For standard textural databases (Brodatz, CURET, KTH\_TIPS, UIUC, Kylberg) consisting of annotated images with homogeneous textures the approach

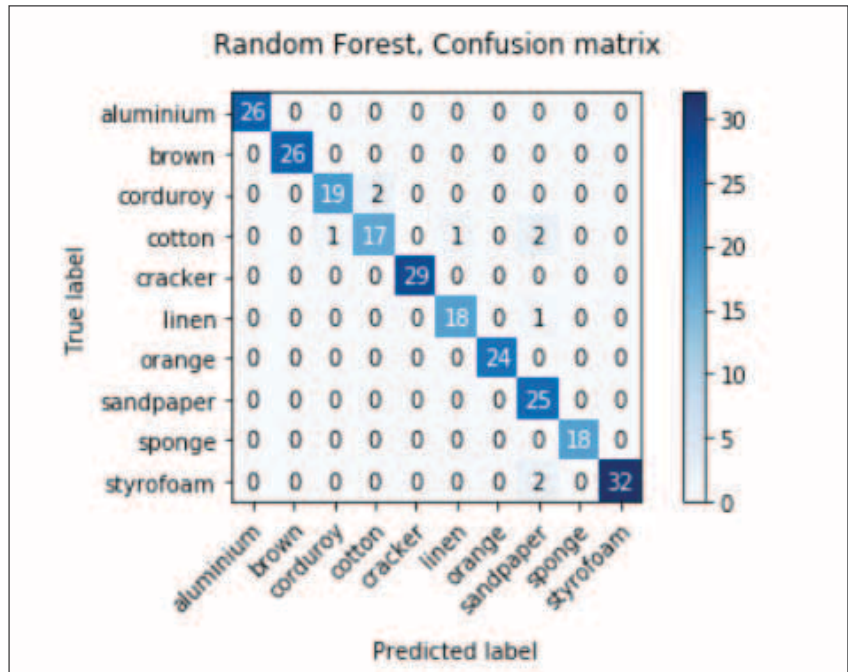

Figure 27-4. Confusion matrix. Off-diagonal elements indicate misclassifications.

produced excellent results (Figure 27-4, using Random Forest as a classification algorithm).

However, real benthic images prove more difficult. A catalogue for real images was constructed using manually prepared masks (Figure 27-5). Large areas in the images occupied with a homogeneous texture were detected reliably, but smaller areas and boundaries had detection problems. This problem will be explored further in future efforts.

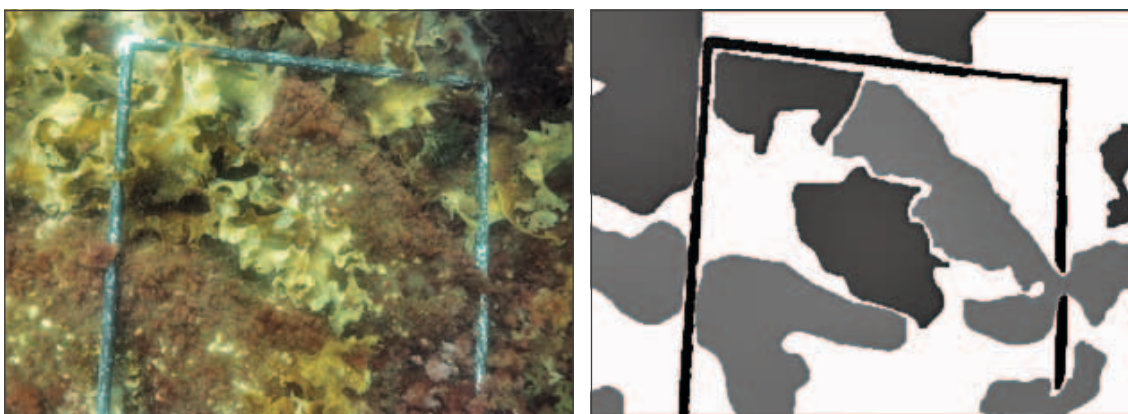

Figure 27-5. An example of an image and a mask for it with three distinct textures (kelp, *Saccharina latissima* and PVC plastic).

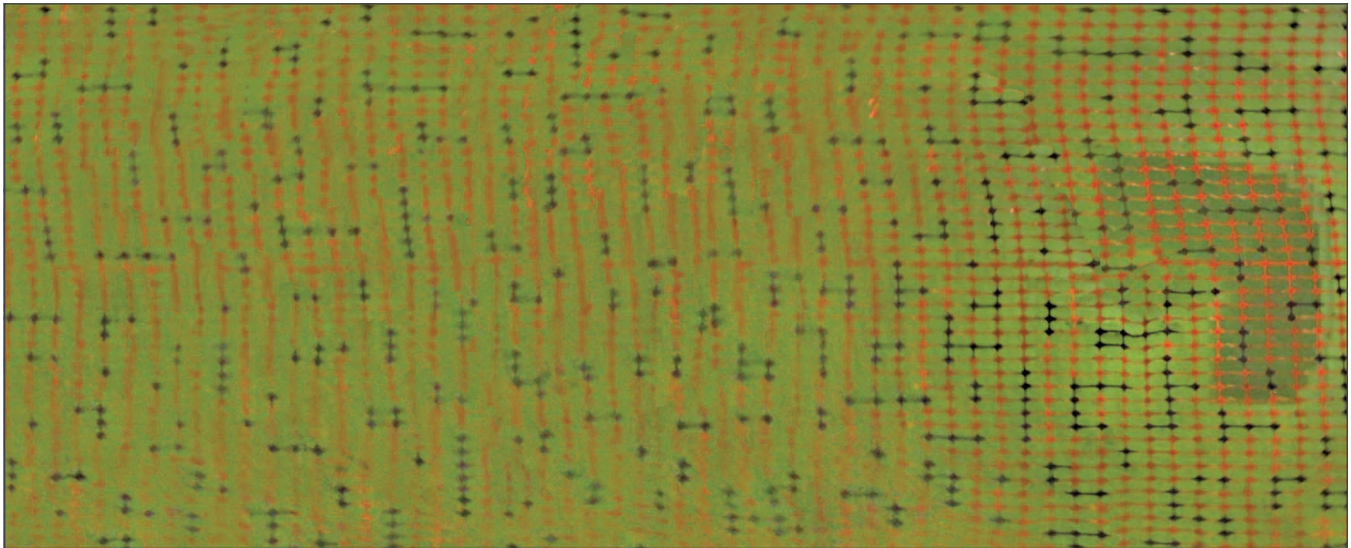

Figure 27-6. Photo mosaic obtained using the proposed device.

## Device for Fault-Proof Collection of Imagery for Underwater Survey

JHC/CCOM Participants: Yuri Rzhanov

The University has applied for a patent (application number 16/667,390) for a device guaranteeing an optimal coverage for an underwater video survey. The idea is to deviate from a widely accepted lawnmower pattern survey and replace it with the circular camera motion. Proper choice of the device altitude, its linear speed, and cameras' rotational speed lead to the following advantages:

- Surveyed area has no gaps in coverage.
- Non-consecutive frames imaging the same area of the seafloor can be easily predicted rather than be manually searched for (this is essential for the application of the Simultaneous Localization and Mapping (SLAM) techniques).
- Survey swath can be arbitrarily wide and depends only on mechanical properties of the device.

The Center conducted a set of experiments to verify the statements made in the patent application. A surface with a random pattern was surveyed with a slowly linearly moving motor with an attached arm with two GoPro cameras. The acquired footage was then processed—lens-corrected, decimated, and sequentially co-registered. The experimentally found interval between overlapping, non-sequential frames was varying in 31-32 range. Automatic registration of frames with this interval allowed for the global registration of the whole mosaic that lead to an almost perfect result.

**TASK 30: Seabed Change Detection:** Continue our efforts to understand the limits to which we can detect changes through understanding of the theoretical limits of both bathymetric and backscatter resolution as determined by sensor characteristics, system integration, and appropriate calibrations and compensations. We will also look at the mobility (or transport) of both inshore and offshore sediments in an effort to better understand the need for re-surveying in different areas. PI: **John Hughes Clarke**

**Project: Seabed Change Detection**

**Other JHC Participant:** Leonardo Araujo

**NOAA Collaborators:** Sam Greenaway and Glen Rice, NOAA-HSTP

**Other Collaborators:** Anand Hiroji (Hydrographic Science, USM), Ian Church (Ocean Mapping Group, UNB), Gwynn Lintern and Cooper Stacey (Geological Survey of Canada), Peter Tallin and, Matthieu Cartigny (Durham University, UK), Juan Fedele and David Hoyal (ExxonMobil Upstream Research Center), Alex Hay (Dalhousie University, Canada)

**Other Funding:** Natural Resources Canada, Kongsberg, ExxonMobil

As every mariner knows, seabed morphology can change, especially in areas of strong currents and unconsolidated sediment such as river mouths and shallow tidal seas. As part of NOAA's mandate to both maintain chart veracity and to monitor dynamic seabed environments, change monitoring is therefore a fundamental requirement. Separating real change from residual biases in the survey data, however, is a major limiting factor in confidently identifying such change. This is the survey challenge that this task addresses.

The seabed change project has focused this year on detecting smaller changes in both shallow tidal channels as well as on the fjord bottom at much greater depths (Figure 30-1). There is a long history of monitoring bedform migration on the Squamish estuary and prodelta in British Columbia. The site is chosen because the field surveys are all funded by other agencies (Natural Resources Canada, Kongsberg, ExxonMobil). The processes observed, however, are equally active in Alaskan and Washington State fjords and in numerous shallow tidal inlets and estuaries along the U.S. coastline.

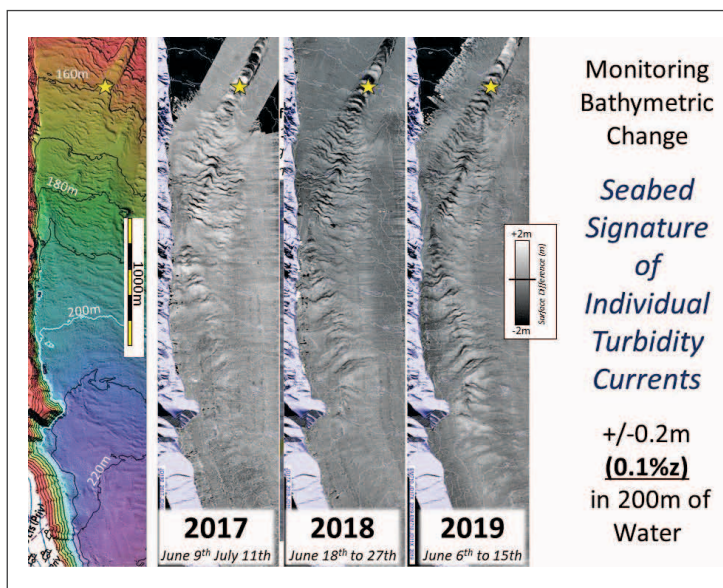

Figure 30-1. Showing the definition of seabed depth changes associated with migrating supercritical bedforms on a submarine fan lobe in ~200m of water. Typical depth changes are at the +/-0.1% of depth scale. These changes are a result of singular turbidity current flows which typically exit the channel mouth (indicated by yellow stars) at ~5m/s (10 knots).

**Shallow Channel (2-10M Depths) Change Monitoring**

In the summer of 2019 we investigated the optimal settings for the EM2040P in very shallow water trying to map decimeter scale ripples in the Squamish River estuary. The estuary has a 3-5 m tidal range with a strong diurnal inequality. The river discharge varies from near zero in the winter to over 1000m<sup>3</sup>/s in flood conditions. The interplay of tides and river discharge result in a highly dynamic shallow channel environment that changes at scales ranging from minutes (observable bedform migration), to weekly (channel deepening and shoaling) to years, (channel lateral migration).

In 2019, bottom tracking of the steep bedforms in this channel was used as the basis for the development of improved bottom detection algorithms using the new water column phase capability of the kmall format EM multi-beams. This is the upcoming master's project of Leonardo Araujo.



**2011-2019 – Squamish Estuary**

A common issue for NOAA–OCS surveys is the delineation of the active channel in shallow tidal inlets. The time scales over which these highly dynamic channels change needs to be estimated so that the required frequency of resurvey may be planned.

The delta top of the Squamish river/estuary is an excellent site for testing just such variability. Because the suspended sediment load is so high, it is not a suitable site for optical remote sensing (either laser bathymetry or satellite remote sensing). Figure 30-2 illustrates the lateral migration of the active channel top thalweg over a period of eight years. As can be seen the channel has eroded into the salt marsh banks a distance of about 50 m. In the same interval, the point bar on the inside of the meander has grown dramatically. Should such a channel be a critical navigational passage, would require survey at least annually.

**Deeper Fjord Bottom Seabed Change**

The deeper water change detection takes place in an area where episodic turbidity currents are active. These flows can be up to 10 m/s yet only last a few minutes. The change observed has two different scales (Figure 30-1):

- A result of upslope migration of bedforms which are ~2-4 m high over a distance of ~1/3 of a bedform wavelength which produces a clear pattern of erosion and accretions zones.
- At the more distal end, the flows lay out sheet like deposits of sediment that are just ~10-40 cm thick in depths in excess of 200 m.

The 2019 summer field season consisted of daily and 10-minute spacing surveys in the areas of activity during spring tides (when the changes most commonly occur) to see if the timing and scale of the seabed change can be constrained. Such dense (in time and space) repetitive surveying places the highest demands on proper multibeam system integration (position, orientation, sound speed and

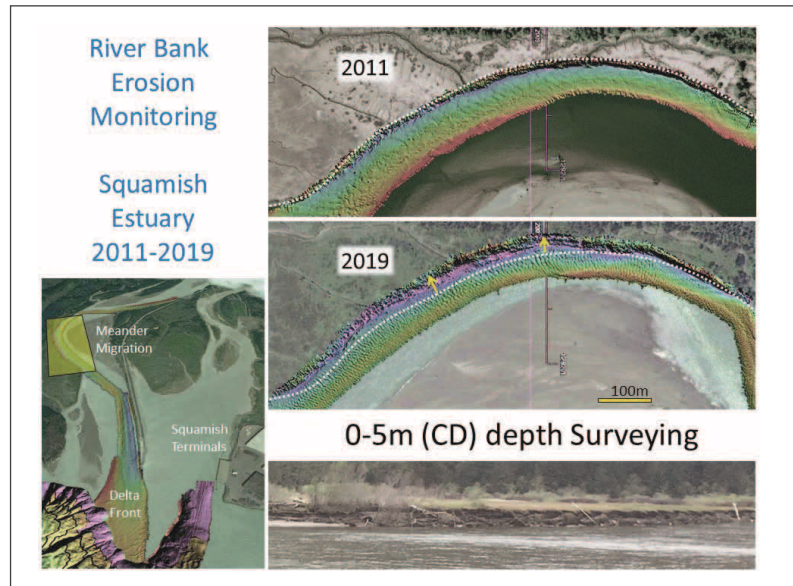

Figure 30-2. Scour Erosion of Salt Marshes through Meander Migration.

bottom tracking). It is thus an excellent test bed to address this task.

To help us understand what is going on, an externally funded (through ExxonMobil) program is running in parallel that has supported the implementation of a series of seabed sensors designed to monitor these rare but powerful flows. These include submerged hydrophone moorings which can “hear” the flow, submerged suspended pressure gauges which

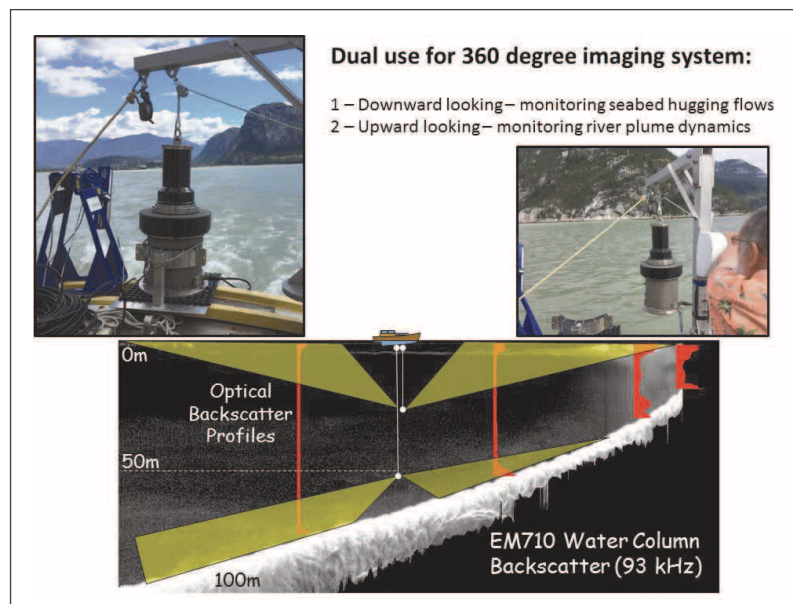

Figure 30-3. Showing the DDS-9001 sonar head on board CSL Heron and the geometry of deployment.

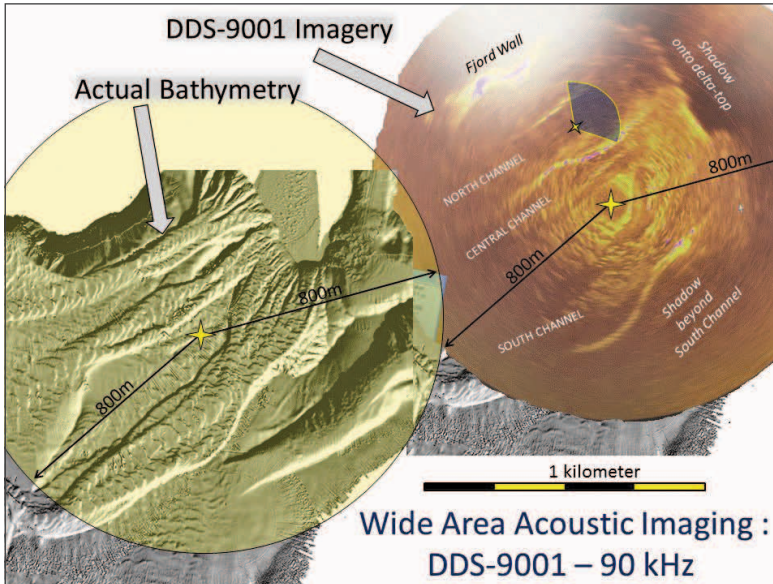

Figure 30-4. Example still image resulting from a single ping of the DDS, showing the morphologic detail achievable. This can be updated at 2 second intervals. Inset arcuate pie shows the coverage previously achievable using the M3 sonar using a 120 degree sector to 150m range.

are pulled down as the flow passes and two ADCP moorings suspended from the surface in 120 m and 160 m of water, just 10 m above the active channel.

The seabed activity occurs over time scales as short as 10-20 minutes. To capture such events places unrealistic demands on mapping platforms, particularly in trying to cover large regions in a short period of time. To address this deficiency, in 2019, for the first time, an innovative acoustic monitoring tool was employed. A circular array, originally developed for diver detection monitoring in ports and harbors, was deployed. This system, the DDS-9001-STT, is a 90 kHz circular array receiver with a steerable stick transmitter (Figure 30-3). Using 20-40 ms FM pulses it is capable of operating out to a range of up to 1200m radius with a two-degree beam width (Figure 30-4).

The DDS was suspended 100 m below the surface from a moored vessel and recorded four hours of data per day around the lower low water period. One active turbidity current was detected.

### Optimal Sonar Configuration

One of the operational aspects addressed is that, for a given integrated multibeam system, the ability to resolve short wavelength relief is, in part, limited by the instrument configuration. The default settings (sector width, vessel speed and pulse setting) are usually optimized to achieve a reliable swath over a sector of about  $\pm 65$  degrees. In doing so, the pulse length choice has to maintain adequate signal to noise at the full slant range. Additionally, the beam spacing is compromised by the requirement to spread the beams over the full four times water depth and wait for the echo from the outermost swath to return.

A particular focus for the 2019 program is to compare and contrast the performance of the EM710 and EM2040 multi-beams (that NOAA and NAVO are now most commonly using). The test platform (CSL Heron) standardly has an EM710. For the 2019 field season we borrowed an EM2040P-MkII to operate simultaneously over the depth range 3 to 300m. Figure 30-5 illustrates the changing resolution capability in 100m of water when using an EM2040P in a variety of pulse length and sector

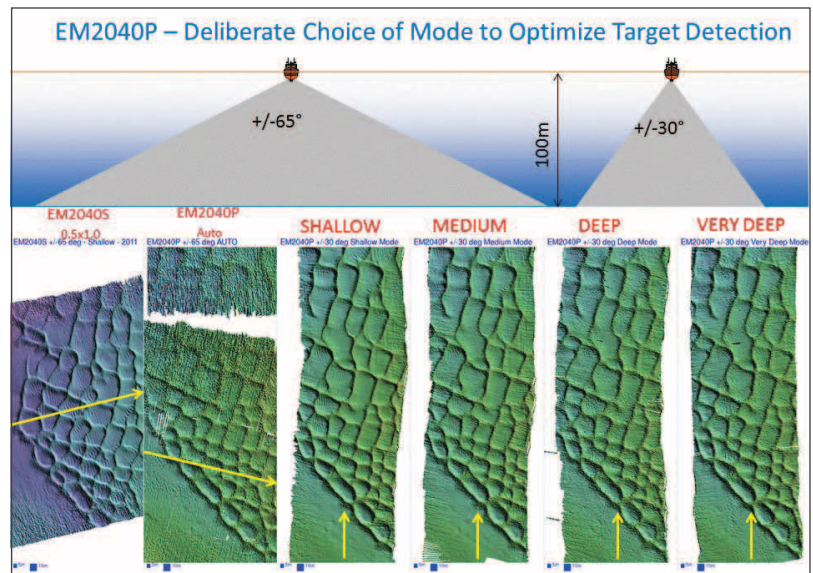

Figure 30-5. Variation in resolution of the same bedroom field using 0.5°x1.0° EM2040 (left) and a 1.3°x1.3° EM2040P. In order to improve the performance of the 2040P, reduced swaths and differing pulse types were tested, the results clearly indicate significant improvement in resolution (at the expense of coverage).

settings.



**TASK 31: Detecting Change in Benthic Habitat and Locating Potential Restoration Sites:** Investigate the use of topographic-bathymetric LIDAR systems and acoustic systems to determine storm induced changes in seagrass, mixed Submerged Aquatic Vegetation, and sand using spatial metrics such as patch size, patch density, and percent cover of benthic habitats from data collected by the EAARL-B topo-bathymetric LIDAR and aerial images.  
 PI: **Jenn Dijkstra**

**Project: Eelgrass and Macroalgae Mapping**

JHC Participants: Jenn Dijkstra, Ashley Norton, and Semme Dijkstra

As part of NOAA/OCS mission to maintain chart adequacy and monitor habitat change, this task focuses on the development of tools and methods that help to delineate and detect change in critical marine habitats. In support of this goal, Center researchers are investigating the use of multibeam water column backscatter and multi-beam derived geofrom features to detect and delineate essential fish habitat, eelgrass and kelp beds. Eelgrass and kelps were detected and segmented based on acoustically derived canopy heights. Identification of specific benthic communities remains a challenge in estuarine and temperate regions using satellite or airborne imagery, hyperspectral or lidar as they rely on the condition of the seas, cloud cover, and depth among other factors. This is the survey challenge that this task addresses.

**Evaluating the Use of BRESS (Bathymetry- and Reflectivity-Based Estimator for Seafloor Segmentation) for Predictive Mapping of Kelp Beds**

JHC Participants: Andry Rasolomaharavo, Jenn Dijkstra, Semme Dijkstra, Rochelle Wigley, Giuseppe Masetti

This year, the project team focused on data processing and analysis of EdgeTech 6205 Phase Differencing Echo-Sounder (PDES) acoustic data. In summer 2018, the sonar was installed on the R/V *Gulf Surveyor* and used to map benthic habitats at six sites at the Isles

of Shoals. Both bathymetry data as well as sidescan sonar data were collected and processed. Backscatter mosaics were created using both Chesapeake Technology Sonarwiz and QPS FMGT. The bathymetry was processed using QPS Qimera.

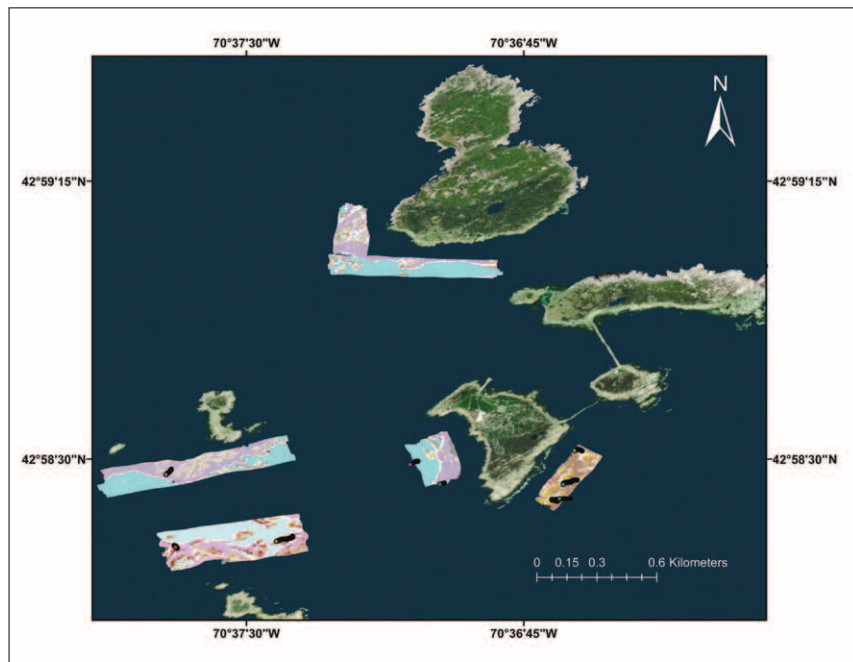

Figure 31-1. Geofoms derived from BRESS observed at six sites at the Isles of Shoals in Maine and New Hampshire. Six landform classes were determined: flat, slope, ridge, valley, shoulder, and footslope.

This study was designed to determine if geofoms could be used to predict kelp and other macroalgae distribution. First, bathymetric landform features were delineated using the Bathymetry- and Reflectivity-Based Estimator for Seafloor Segmentation (BRESS) software program for acoustic and terrain analysis (Masetti et al. 2018—see Task 18). BRESS was applied to the final bathymetry dataset only because the final backscatter mosaics had irreparable errors. Six geofom classes were determined—flat, slope, ridge, valley, shoulder, and footslope (Figure 31-1). Overall, the algorithm effectively delineated the major features of geomorphic interest at the six sites. A key advantage of the automated classification completed



with the BRESS approach is the ability to apply the same methods to similar features for consistency of results.

Second, data were imported into ArcGIS which allowed for the creation of queries comparing the acoustically derived products and the ground truth data. Third, the near simultaneous collected ground truth data of underwater video and still images were interpreted for macroalgal dominance. Dominance of taxa in video footage was assessed in 1-10 second snippets for easy comparison of habitat with geofoms. Correspondence between the video snippets, still images, and geofoms generated by BRESS were determined using the intersect tool in ArcMap. Overall, slope was found to be a good predictor for macroalgal presence (Figure 31-2). Turf macroalgae were more common on ridges and kelp was slightly more common on shoulders and slopes.

### Mapping Macroalgae Using Water Column Backscatter

JHC Participants: Ashley Norton, Semme Dijkstra, and Jennifer Dijkstra

This report builds on previous work designed to determine the effect of current induced canopy posture on the shape of the acoustic return signal from the canopy and seafloor, on development of methods for angle-of-incidence corrections and application to acoustically derived eelgrass and macroalgae canopy heights collected from field surveys, and a new method for comparing *in situ* canopy heights to acoustic canopy heights that takes into account the difference in spatial resolution for measuring methods between the acoustic returns and ground truth data. This reporting period, the project team focused on a habitat verification study of data collected at the Isles of Shoals and on disseminating results from the previous studies.

Acoustic canopy height data, collected at five sites at the Isles of Shoals (Figure 31-3), was classified into kelp and non-kelp habitat. Percent cover of kelp, non-kelp and bare substrate of these habitats were determined and compared to percent of 100 m<sup>2</sup> photomosaics of the seafloor collected by underwater video footage (Figure 31-4). The purpose was to determine if acoustic water column backscatter can be used to assess percent cover of kelps, an essential fish habitat.

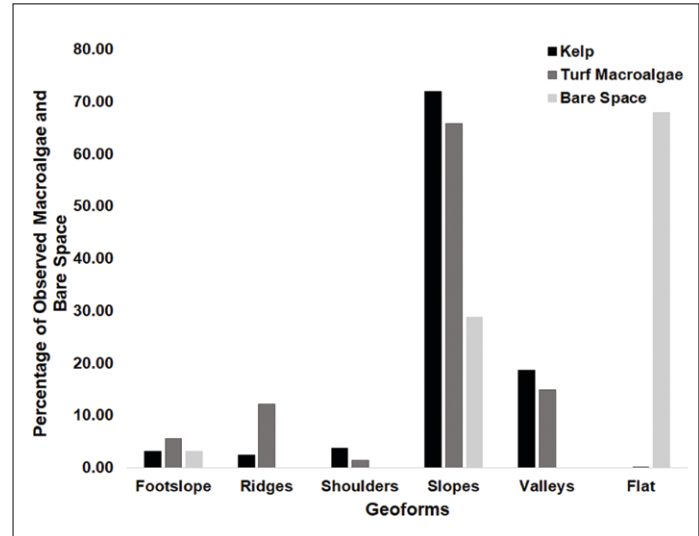

Figure 31-2. Within group (e.g., kelp, turf macroalgae) percentage of macroalgae or bare space as a function of the six landform types. Greatest percentage of kelp and turf macroalgae was observed on slopes.

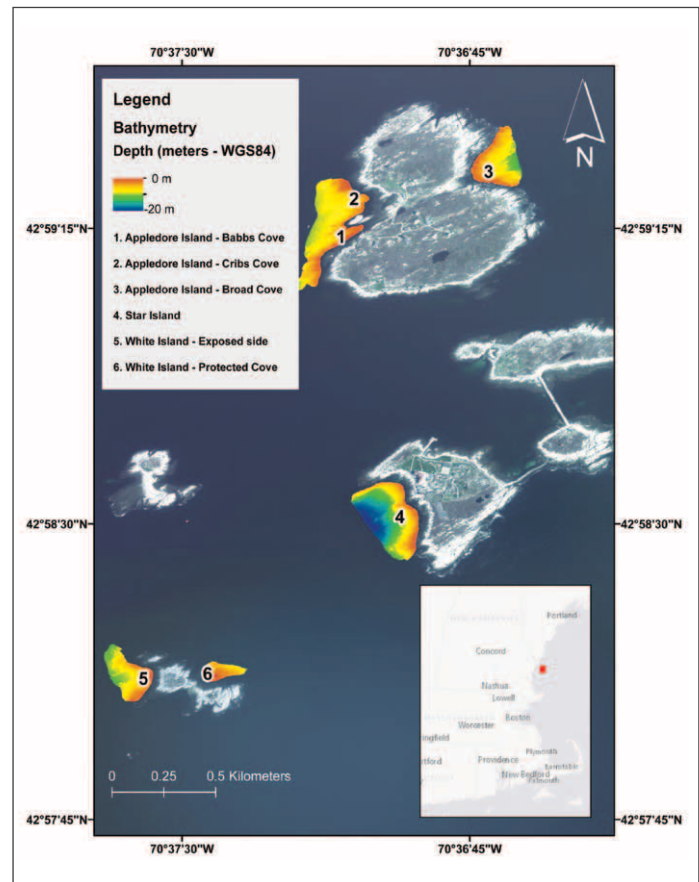

Figure 33-3. Bathymetry of sites at the Isles of Shoals.

Overall, there was good correspondence of kelp cover between multibeam and in-situ percent cover of kelp (Figure 31-4). The sonar-derived habitat type classification overestimated the percentage of bare areas at every site relative to the diver mosaics. The bare areas observed in the acoustic data represent sandy areas that divers did not capture. This was expected as the study was intended to distinguish among macroalgal communities. Consequently, the photomosaics were collected in shallow hard bottom areas chosen for the presence of macroalgal habitats. It was noted that at Cribbs and Babbs Coves in particular, a large, bare sandy area was present in the deeper sections of the area surveyed with the multibeam, and this is reflected in the sonar-derived estimate of approximately 68% cover of unvegetated, bare substrate. White Island Cove was the smallest site, covering only 2245 m<sup>2</sup>, with a shallow area entirely dominated by a short macroalgal species and a deeper area dominated by kelp species (J. Dijkstra, unpub. data); the disparity in estimated kelp habitat cover is therefore expected as the photomosaic data were collected in the shallow, short macroalgae-dominated area.

In the course of this study, several lessons were learned that could further improve acoustic surveys intended to measure canopy height. The first lesson

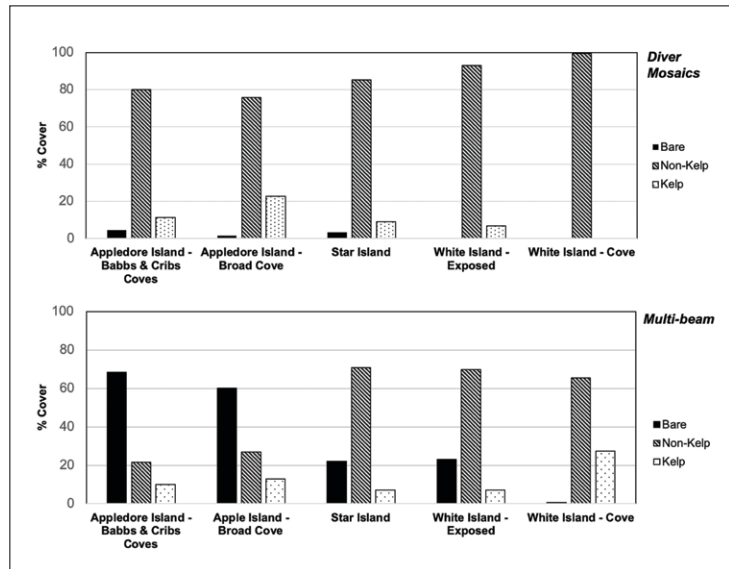

Figure 31-4. Comparison of ground-truth photomosaics (A) and acoustic derived (B) percent cover of kelp, non-kelp and bare substrate (see text for further explanation).

is that steep slopes of the survey area would need to be accounted and corrected for as sloped terrain can artificially lengthen waveforms and lead to false-positive detection of a tall canopy height. The second lesson is that it is best to avoid across-track slope-induced sidelobe, as simple amplitude-threshold based filters are difficult to implement due to the fact that relative amplitude of returns are unknown for most macroalgae.

### Enhanced Mapping of Critical Coral Reef Habitats Using Lidar Waveform Metrics and Photomosaics

**JHC Participants:** Jenn Dijkstra, Kristen Mello, Yuri Rzhanov, and Matt Tyler

**NOAA Participants:** Tim Battista and Bryan Costa (NOAA/NCCOS)

**Other:** Christopher Parrish and Nick Wilson, Oregon State University

While acoustic techniques are most effective in temperate ecosystems or in deeper waters, lidar is an effective method for mapping nearshore benthic habitats in tropical or near-tropical regions. New topobathymetric lidar waveform metrics coupled with seafloor photomosaics of 100m<sup>2</sup> were used to find relationships between waveform metrics, seafloor, and coral reef properties. Linking remote sensing derived data with biological and seafloor properties of benthic habitats provide novel information that improves the probability of establishing baselines and detecting fundamental temporal changes in benthic habitats at 10s to 100s of meters and in areas that are dangerous or inaccessible to divers. Benthic maps that depict the spatial extent of morphological forms of corals are valuable in managing essential fish

habitats as upright branching corals provide a better habitat than mounding corals for fishes. These tools will also help in understanding in what areas depth readings may be affected by the presence of submerged aquatic vegetation, and even estimate by how much.

For this reporting period the project team have been disseminating results describing methods for lidar signal processing using the EAARL-B topobathymetric lidar and correlation of extracted lidar waveform features to coral morphology. Results from this study indicate the waveform features of standard deviation of skewness and standard deviation of area under the curve are promising for detecting changes in the morphological composition of coral reef communities.

## Evaluating the Use of Photomosaics for Fine-Scale Mapping of Habitat Use by Commercially Valuable Species

**JHC Participants:** Jenn Dijkstra, Kristen Mello, and Yuri Rzhanov

**Other:** Nathan Furey (Department of Biological Sciences)

The coastal ocean floor is seeing a marked decline in tall, leafy native kelp forests and an inundation of short, shrub-like invasive seaweeds. These near-shore coastal ecosystems are designated as Essential Fish Habitat for a variety of fishes and crustaceans and are considered a sentinel for ecosystem change. In other areas of the world where there have been similarly drastic declines in kelp, the results have been reduced diversity of species and in some cases a total collapse of commercial fisheries.

The loss of kelp in the Gulf of Maine to commercially valuable species is not known but may be a significant problem for the region's coastal economy and the health of its coastal ecosystem. In particular, the Gulf of Maine's valued lobster and crab fishery. To

understand how lobsters and crabs utilize habitats, fine-scale mapping of habitat was coupled with tracking of tagged lobsters and crabs. In this reporting period, the team collected underwater video footage in June/July of 2019 of a 1,200m<sup>2</sup> area over six dives using two GoPro Hero Black 7s. Using updated programs developed by Rzhanov, the team is stitching the footage together to form a single photomosaic of the seafloor. The mosaic will be georeferenced and imported into ArcMap along with the acoustic receiver data that recorded fine-scale movement of lobsters and crabs in the habitat

This project is ongoing with the intent to evaluate the use of photomosaics for micro-habitat use by tracked lobsters and crabs.

## Enhanced Mapping of Essential Fish Habitat Using Structure from Motion

**JHC Participants:** Jenn Dijkstra, Jordan Pierce, Kristen Mello, Matt Tyler, Yuri Rzhanov, Tom Butkiewicz, Colin Ware

**Other:** Mark Butler, Old Dominion University

Structure from Motion (SfM) photogrammetry is a technique that has been used for the production of high-resolution morphometric 3D models and derived products such as digital surface models, and orthophotos. SfM has been used in morphodynamic studies and reconstruction of complex coastal geofoms, coral habitats, and rocky shores. These models can provide small (< 1m<sup>2</sup>) and large scale (10-100s of square meters) quantitative three-dimensional information of seafloor and habitat characteristics that can be used for shoreline surveys and to monitor habitat change. Preliminary testing of a stereo-camera system and SfM techniques were performed and model accuracy determined with the goal of assessing complex habitat structure in habitats designated as Essential Fish Habitats (EFH) or Habitats of Particular Concern (HPC).

SfM algorithms reconstruct scenes by identifying common key-points or features within multiple images that are invariant to changes in scale, lighting and rotation. With sufficiently dense key-points and estimations of the intrinsic of the camera used (e.g., focal length, focal distance), points can be assigned a relative third dimension in some arbitrary space. For accurate models to be produced, images need to be

of a high resolution in order to maximize the number of key-points within the scene, as well as contain significant overlap between different images, the trade-off being computational complexity.

In previous reports, the project team have experimented with reconstructing 3D models from underwater video footage collected by a GoPro Hero 3+ using SfM software, Agisoft's Photoscan. The most significant problem is the distortion of the fisheye lens. Previous attempts using multiple calibration methods could not remove the distortions resulting from refraction of the fisheye lens due to the water. As a result, the Center acquired two Cannon 70D DSLRs with 20 mm lenses, two Aquatica underwater housings with a 6" dome port, and two Sea & Sea strobes in an attempt to eliminate distortions due to refraction. Once placed in underwater housings, cameras do not move and the system essentially functions as a pinhole camera which appears to reduce distortion resulting from refraction. Another advantage of using these cameras over point-and-shoot cameras like the GoPro is that the user can define the optimal settings for a specific underwater condition, and these settings can change as water conditions change. Our previous report focused on the



creation of preliminary models of the seafloor using standardized approaches and found that the creation of 3D models is computationally expensive. In this reporting period, further testing of model quality on seaweed dominated habitats is being performed using a range of compressed images and the updated Agisoft software program (now Agisoft Metashape). Preliminary results indicate that Metashape uses improved depth-mapping algorithms to generate its meshes and uses depth maps instead of dense point clouds to create 3D models. This reduces computation time for individual models. The new model using compressed images was created more quickly and is 355 MB in size (when exported as a "ply" model), compared to the original 511 MB. This project is ongoing with the intent to compare model sharpness and habitat morphometrics using depth maps and dense point clouds.

As many industrial, academic and government entities ground-truth acoustic data or re-create benthic habitats using GoPro, two GoPro 7 Hero Black cameras were acquired to examine if distortions resulting from refraction on the newer GoPro can be reduced thorough calibration. Camera calibration is meant to

identify the intrinsic and extrinsic parameters (e.g., principal point, focal length, lens distortion) inherent to the camera system that may affect the accuracy of the model reconstructed; each camera has slightly different components due to inconsistencies during production. For this year, the project team focused on identification of intrinsic values of each camera system, comparison of 3D model reconstruction using still images and those extracted from the video mode setting, application of coded targets to the reconstruction process, and field testing the system on patch reefs with and without moving macroalgae in the NOAA Chica Marine Reserve in the Florida Keys.

Intrinsic values of the cameras were identified by finding the distortion error between the 2D mappings of a real-world object with known dimensions. Once distortion errors were known, corrections were then applied to each image. Model reconstruction was then tested using still photographs (camera setting mode) and using video. Video as a method of extracting stills does appear to provide a model that is comparable to images taken with a camera. Extracting many stills and only retaining those of a

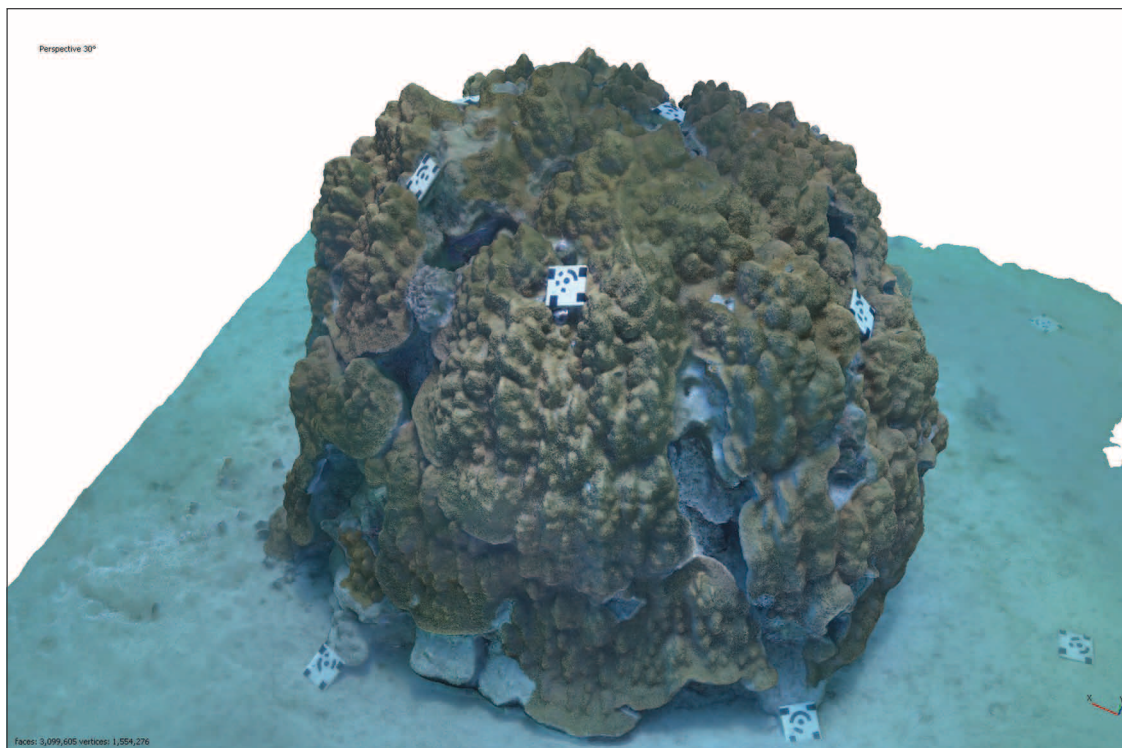

Figure 31.5. Textured 3D model of a 3x2 meter coral patch without macroalgae reconstructed with Agisoft's Metashape.

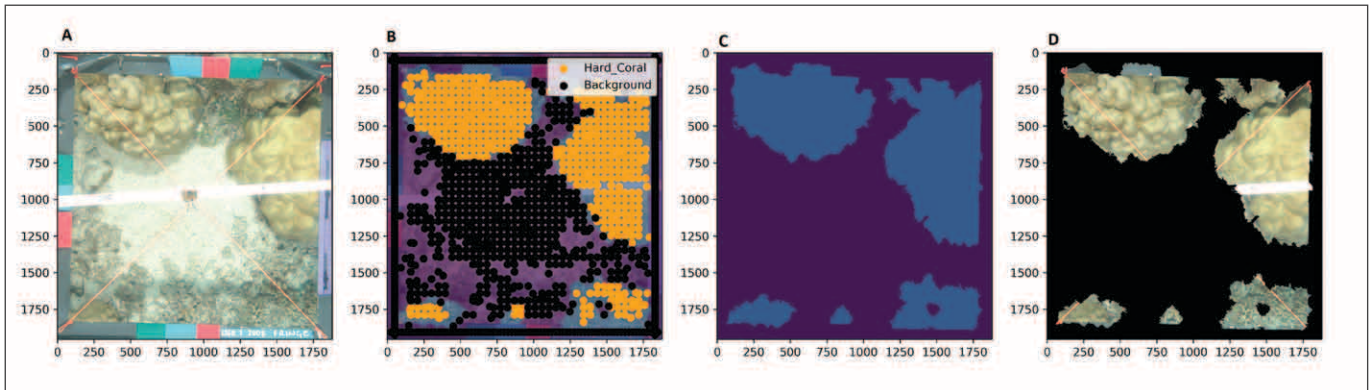

Figure 31-6. Process of generating masks for each class category and its use as training data for the deep semantic segmentation algorithm: (A) Sample image from the MLC (2000x2000 pixels) dataset (B) Image with more labelled points by trained artificial intelligence that act as autonomous annotator, (C) Groupings of pixels belonging to the same class category created by a SLIC algorithm, (D) Masked class images.

high quality might also be a quick and easy automatic method for obtaining the best stills. Model reconstruction was also tested with and without the use of coded targets. The coded targets help to limit the amount of points used by the point matching algorithm, decreasing computation time and increasing alignment and point matching accuracy.

Cameras were mounted on a frame to create a stereo camera pair and field tested on patch reefs with and without macroalgae in the Florida Keys. Macroalgae is not stationary and thus provided a good comparison of model results with and without moving algae. In July 2019, Pierce, Ware, and Dijkstra collected underwater video footage on isolated coral reefs, while Pierce remained to collect additional data on coral patch reefs found in the Chica NOAA Marine Reserve. Coral patches measured between 5-8 meters in diameter and were under 10 meters in height. First, video footage was collected of the entire reef. Second, any macroalgae observed on the patch was removed manually by a group of divers and followed

by a second run of video collection. Before and after video footage was collected for five separate coral patches. Footage was collected using standard lawn mowing patterns with additional passes at highly oblique angles. To assist in photo alignment and accurate geometric reconstruction, coded targets were strategically placed throughout the scene providing a method of auto-calibration and ground control points. The use of coded targets proved invaluable in reconstructing 3D models with species that move with water motion as the targets provided a non-moving object which aided the alignment of images. For this reporting period, a method was developed for model reconstruction using the popular commercial software package, Agisoft's Metashape, and patch reefs are currently being processed (Figure 31-5). This method includes image processing and target measurements parameters with whole model measurement errors less than 1%. These models have also been fed into virtual reality and novel tools designed to measure various features (e.g., length, size, volume) are being developed by Butkiewicz.

### Application of Deep Learning for Coral and Macroalgae Classification

JHC Participants: Jordan Pierce, Yuri Rzhanov, and Jenn Dijkstra

High-resolution imagery data provides a precise view of seafloor environments and allows insight into important biological and physical metrics that gives indication regarding the health and well-being of seafloor habitats. With current technology, it is possible to collect and store large amounts of digital imagery data. The annotation of this data however,

is an expensive and time consuming task which is almost always preformed manually by a trained expert. In an attempt to reduce the amount of time required to annotate data, this research aims to develop a method that utilizes computer vision and deep learning algorithms to assist in autonomous annotation of imagery data.

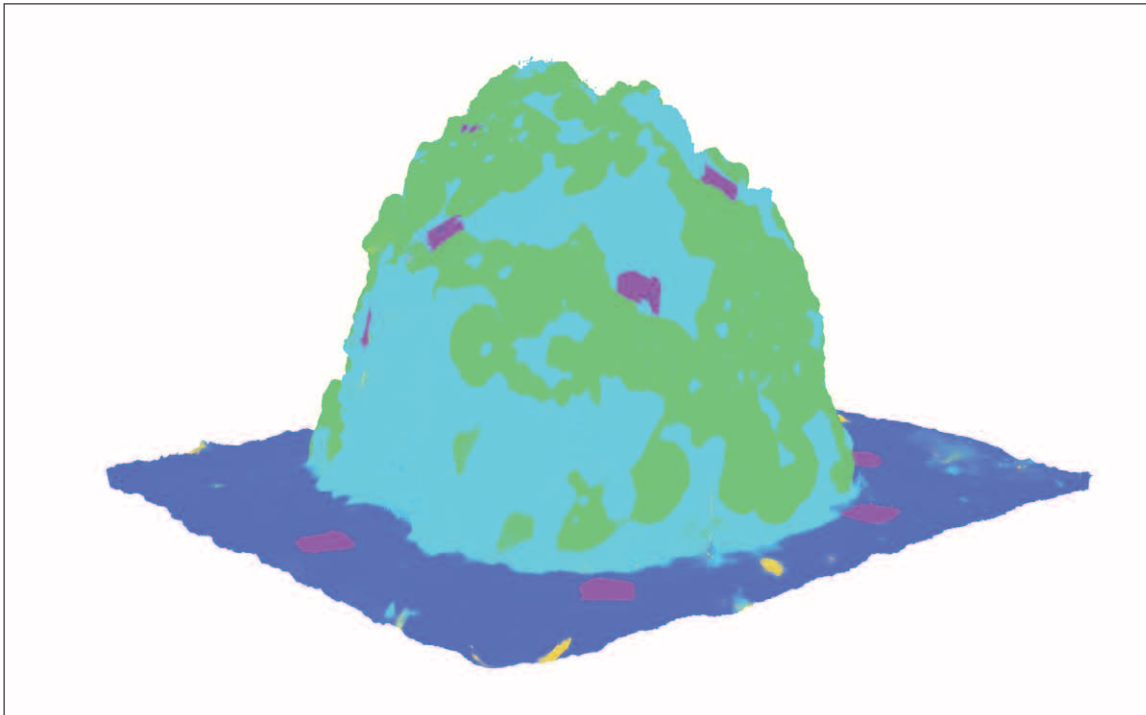

Figure 31-7. A 3D-model representing a second coral patch, with a texture overlaid describing the class category of each face that makes up the mesh. Classifications were provided by a deep semantic segmentation algorithm after being trained with data annotated with the patch extraction tool.

Initial development of the method used the Moorea Labeled Coral (MLC) images. Each of the ~2055 images have been annotated (200 points/image) by experts and thus are ideal for development of methods for taxonomic segmentation as they are well ground-truthed (Figure 31-6). However, during method development, it was discovered that the original amount of annotations on the MLC dataset was insufficient to fully train for automated taxonomic classification. One solution was to use Artificial Intelligence (AI) to quickly generate more annotations. This was done by randomly extracting image patches from the original images and feeding them directly to the deep learning model. Those image patches that had a high degree of confidence of being correct were retained while the rest were discarded (see Figure 31-6 for workflow). The retained image patches were then very quickly perused to confirm that the annotations were correct. The image classifier was then retrained with additional sets of images. This cycle was repeated until a specific criteria of accuracy was met.

Once AI was trained as a proficient image annotator, each image within the dataset was provided with additional labelled points contributing to the already existing points. With enough annotations, whole areas consisting of contiguous labels of the same

class category were combined using Simple Linear Iterative Clustering (SLIC) algorithm. This algorithm joins the pixels of an image that are similar in color and texture into distinct groups. This step accurately converts the sparse-labels into dense-labels (i.e., pixel-level annotations), which can then be used as training data for a state-of-the-art deep semantic segmentation algorithm capable of performing whole image predictions in near real-time.

The above method was tested and refined on extracted still images of underwater video footage of coral reef patches collected from the Florida Keys. Point annotations were provided manually using an image patch extraction tool developed by Rzhanov, which allows users to quickly annotate areas of the image using a graphical user interface. This tool generated highly representative samples of each taxonomic class category, limiting the overall annotations needed to be done manually before training an image classifier capable of providing autonomous annotations on the remainder of the dataset. Once the deep semantic segmentation model was trained, it was applied to the extracted still images used for 3D reconstruction of coral reef patches. This provided a 3D assessment of the spatial distribution of different taxa within a patch reef (Figure 31-7).



**TASK 32: Marine/Coastal Decision Support Tools:** Development of approaches to creating interactive decision support tools that can integrate multiple data sources (e.g., bathymetry, sediment texture, zoning, habitat mapping, ship-traffic) with advanced visual analysis tools (e.g., probes and lenses). Pls: **Tom Butkiewicz and Vis Lab**

**Project: Web-based Soundscape Mapping and Acoustic Visual Analysis**

**JHC Participants:** Thomas Butkiewicz, Ilya Atkin, Colin Ware, Jennifer Miksis-Olds, and Anthony Lyons

**Additional Funding:** BOEM

Many people, from mariners to politicians, now rely on web-based data portals to investigate, understand, and make decisions about coastal and marine areas. However, these web-based interfaces often provide only basic map functionality. To support better decision making, the Center is investigating ways to extend these interfaces with better interactive visualization techniques and spatial analysis tools. End users that will benefit from these improvements include those working in coastal planning and zoning, survey planning, and environmental analysis.

Thomas Butkiewicz and Ilya Atkin have been developing a web-based soundscape mapping, and acoustic, visual analysis interface as part of the Atlantic Deepwater Ecosystem Observatory Network (ADEON) project, which is being leveraged to further the Center's goals of developing marine and coastal decision support tools. ADEON is a BOEM-funded program designed to collect long-term measurements of both natural and human sounds in the outer continental shelf region (see Task 56 for more details).

Advanced interactive visualization tools are critical for transforming the massive amounts of data being collected into useful insights for ecosystem-based management efforts. Long-term observations of living marine resources and marine sound will assist Federal agencies, including BOEM, ONR, and NOAA, in complying with mandates in the Endangered Species Act (ESA), Marine Mammal Protection Act (MMPA), and Sustainable Fisheries Act (SFA).

A basic version of the interactive mapping site is now live, while our unpublished (pending sponsor approval) internal version has more features, including the integration of new data sources/layers, such as wind speed and chlorophyll, that provide helpful context for the sources and influencing factors of sounds detected by the array of landers. These layers can be animated via the time bar at the bottom of the interface, which has start/end ticks to control the time span that animation occurs over. Modelled soundscapes, once available, will also be shown and animated via this interface.

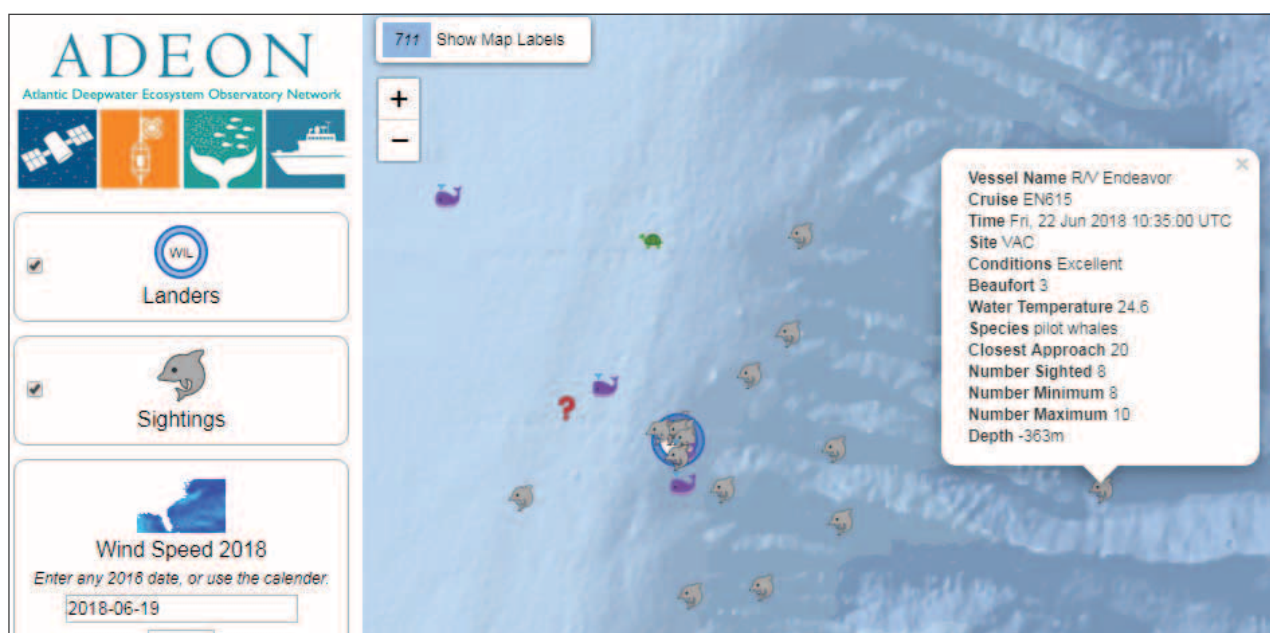

Figure 32-1. Marine animal sighting data from an R/V Endeavor cruise plotted on the web map. Clicking on a sighting icon brings up detailed information.

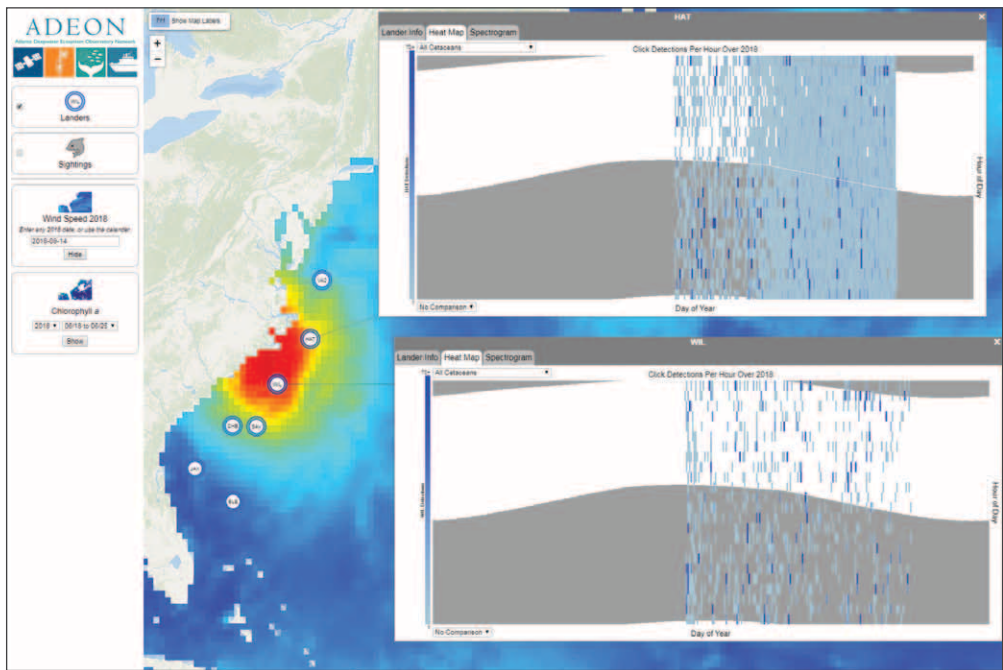

Figure 32-2. The background layer shows the winds during the landfall of Hurricane Florence, while the two heat map interfaces in the foreground show cetacean detections around the Wilmington and Cape Hatteras landers.

Marine animal sighting data from the cruises were integrated into the mapping interface (Figure 32-1). By turning on the “sightings” option, small icons of each species type are displayed around the lander sites. Clicking these brings up the relevant data for that sighting in a small popup window.

Heat map visualization interfaces were developed for viewing event detections, such as marine mammal calls, shipping tonals, seismic pulses, etc. When

starting and ending during the pattern (e.g., cutting at midnight each day or at Dec 31st/Jan 1st each year).

Users can also compare events at multiple landers. Figure 32-3 shows a plot comparing the frequency of cetacean detections between the BLE and VA2 landers. It shows that first there was a period of few detections, then a period in which there was much more activity at both sites, but more so at the VA2 site (more red than blue or purple).

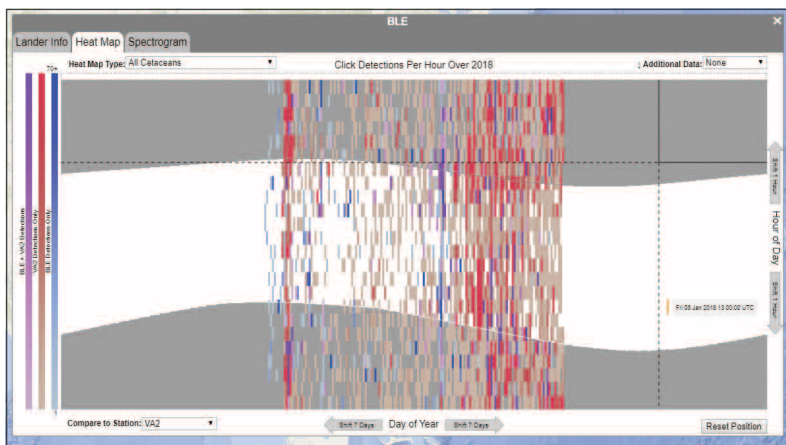

Figure 32-3. Heat map interface comparing the cetacean detections between two different lander sites.

Another tab in the lander interface provides our novel tri-level spectrogram viewer, which is now fully functional and displays the ADEON’s first six months of data. As shown in Figure 32-4 and 32-5, this view presents the lander’s recordings in spectrogram form, at three different time scales.

These three time scales act as zoom levels:

- The top level provides a multi-week (depending on screen resolution) overview of the dataset, in which trends, spikes, and long-time-scale features (ship transits) are visible.

This is where users can quickly explore the dataset and find interesting things. Clicking on something in the top level causes the interface to immediately brush the lower two levels to the same time.

- The middle level shows a day-scale visualization, where each pixel width is equal to about 30 seconds of data. Here one can see most features, at a slightly zoomed out scale. Clicking anywhere here brushes the lowest level to that time.

- The lowest level shows the data at half second resolution and is the most useful for identifying features and marine mammal calls. Mousing over this spectrogram shows the exact time and frequency at each point.

By pre-processing all of the recording data and storing the resulting spectrograms as highly compressed images in our online database, users are able to easily and quickly explore the massive (hundreds of gigabytes) ADEON dataset from anywhere.

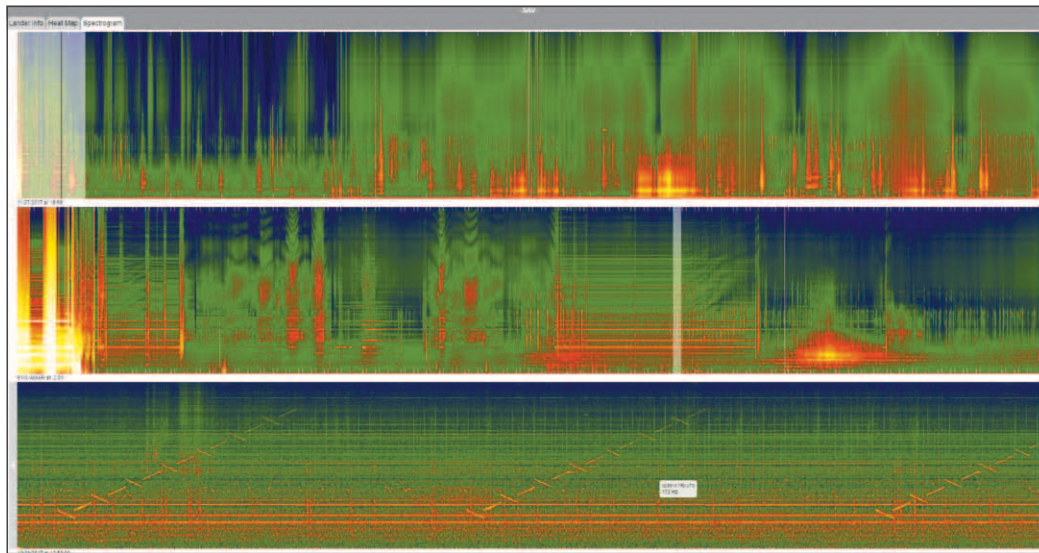

Figure 32-4. The tri-level spectrogram viewer displaying signatures of a sonar unit being used near the lander (lowest level, diagonal upsweeping lines).

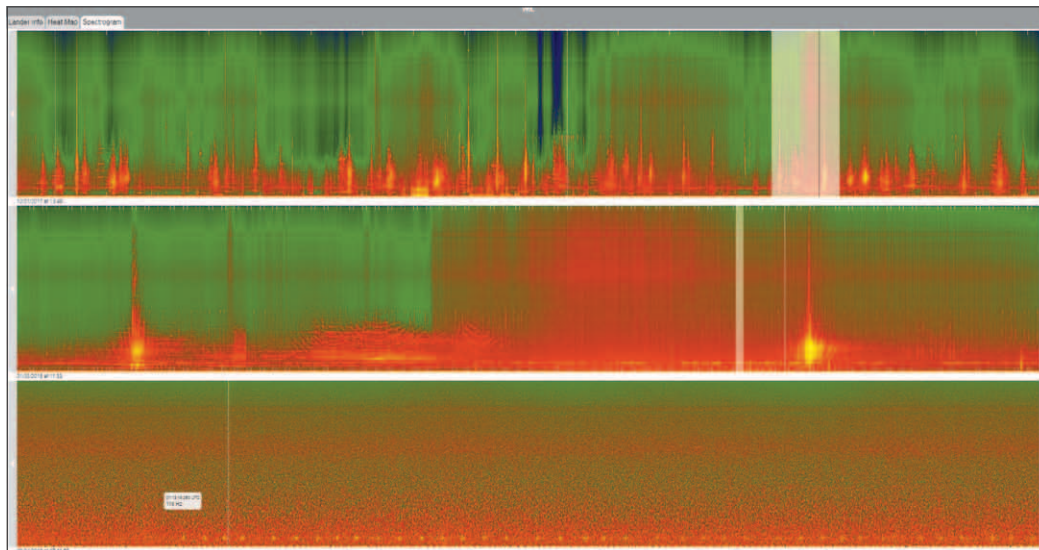

Figure 32-5. The tri-level spectrogram viewer showing fin whale calls (repeating yellow dots across the very bottom)



**TASK 33: Temporal Stability of Seafloor:** to address the problem of temporal stability of the seafloor we will combine our remote sensing expertise and ability to remotely map seafloor change with our studies of seafloor stability and its relationship to forcing conditions to attempt to derive indices of temporal seafloor stability that can then be input into navigational risk models and used to inform NOAA and others of the needed frequency of repeat surveys in certain regions. **PI: Tom Lippmann**

**Project: Seafloor Stability**

**JHC Participants:** Tom Lippmann, Kate von Krusenstiern, Jon Hunt, Jim Irish, Salme Cook, and Joshua Humberston

The goals of this task (master's thesis of Kate von Krusenstiern) are to assess the quality of bathymetric data in shallow navigable waterways, and to determine the "likelihood" that a nautical chart depth in an energetic shallow water region with unconsolidated sediment is valid a certain length of time after the data were collected. This will allow us to estimate re-survey timescales in shallow water sedimentary environments with commercial and recreational navigational needs.

Two approaches have been taken. The first is a study of the bathymetric evolution in Hampton/Seabrook Estuary in NH. The second involves a study of shoal movements and sediment transport pathways around Oregon Inlet, NC (undertaken by DOD SMART Fellow Josh Humberston in collaboration with Dr. Jesse McNinch of the USACE Field Research Facility in Duck, NC).

In the first aspect of this task, we previously (2016) measured the bathymetry in the inlet and the back bay of Hampton/Seabrook Harbor using the Coastal Bathymetry Survey System (CBASS). These bathymetric data have been used to establish an instance of the Coupled Ocean Atmospheric Wave and Sediment Transport (COAWST) model. Previously (fall of 2016), Von Krusenstiern created a composite topographic-bathymetric model of the Hampton/Seabrook, NH region from data sources that included the Center, NOAA, and USGS bathymetric surveys conducted on the inner shelf, USACE lidar surveys (primarily 2011) spanning the inlet, harbor, and nearshore topography, and compilations from the USGS coastal relief model for elevations up to 8 m above mean sea level. Comparisons with our 2016 survey show significant changes in the bathymetry, including the cutting of new tidal channels in the harbor and infilling of the navigational channel where New Hampshire's fishing fleet moors many of their vessels. As part of von Krusenstiern's master's

thesis research (nearing completion), she will use the COAWST model to simulate the sediment transport in Hampton Harbor for five years between 2011 and 2016, and compare to the change in observed bathymetry to verify the model.

As part of our efforts to verify the hydrodynamics, pressure sensors, current moorings, temperature gauges, salinity sensors, and optical backscatter sensors were deployed at nine locations within Hampton Harbor for 30 days in the fall of 2017 (Figure 33-1). These data have been compared with simulated model runs driven by observed water levels on the shelf (and include both tides and subtidal motions). Model-data comparisons of M2 tidal amplitude decay and phase change within the back bay were used



Figure 33-1. Map of Hampton Harbor showing the location of instruments deployed for 30 days in the fall of 2017 to measure wave, currents, temperature, salinity, and optical backscatter. Data from these instruments will be used to verify the hydrodynamic model and set the proper bottom boundary condition for the model.

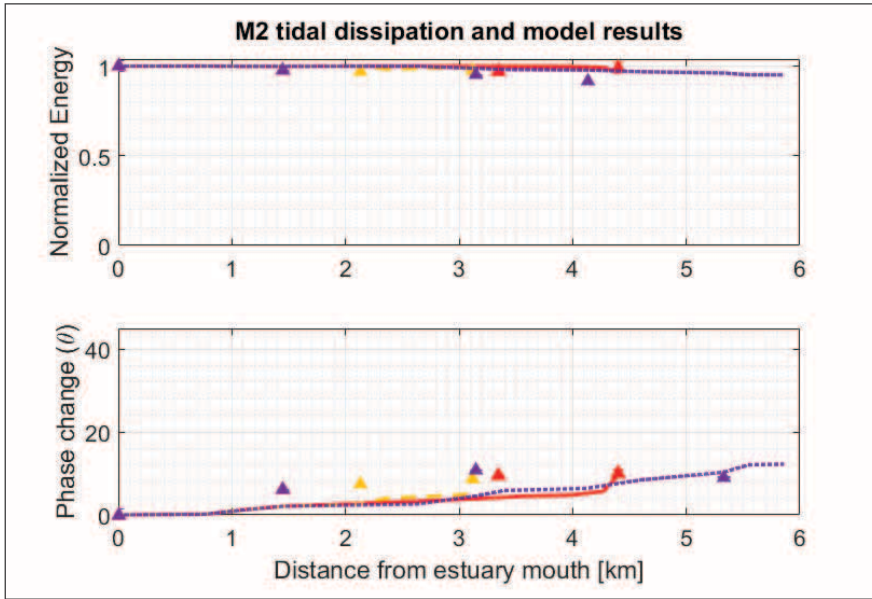

Figure 33-2. The modeled M2 tidal amplitude (upper panel) and phase (lower panel) changes for the north (blue), middle (green), and south (magenta) channels of Hampton Harbor. The observations (symbols) obtained in 2017 are used to verify the model simulations.

to determine the correct bottom boundary roughness condition specified in the model consistent with the observations. Figure 33-2 shows the modeled evolution (amplitude and phase changes) of the M2 tide as it propagates into the three main channels of Hampton Harbor back bay area. Observations of currents were also used to verify the simulated flow

fields over the 30-day deployment period (Figure 33-3). The verified hydrodynamic model can now be used to initiate the sediment transport model within COAWST (the Community Sediment Transport Model, or CSTM). However, to properly model the sediment transport, the sediment characteristics must be specified spatially throughout the model domain.

Four years of sediment data (2005, 2007, 2011, and 2015) encompassing the nearshore region, beaches, inlet, and back-bay of the study area have been compiled and analyzed in order to create a realistic sediment distribution map for Hampton/Seabrook Harbor. Four representative grain sizes—one mud class (0.03 mm), and three sand classes (0.15 mm, 0.75 mm, 3.0 mm)—were determined by assembling the total of 116 grab samples into a single database and looking at the sediment grain size distribution range. This application is limited to four grain sizes to maximize computation efficiency of the numerical model (each additional grain size adds to the total run time).

to determine the correct bottom boundary roughness condition specified in the model consistent with the observations. Figure 33-2 shows the modeled evolution (amplitude and phase changes) of the M2 tide as it propagates into the three main channels of Hampton Harbor back bay area. Observations of currents were also used to verify the simulated flow

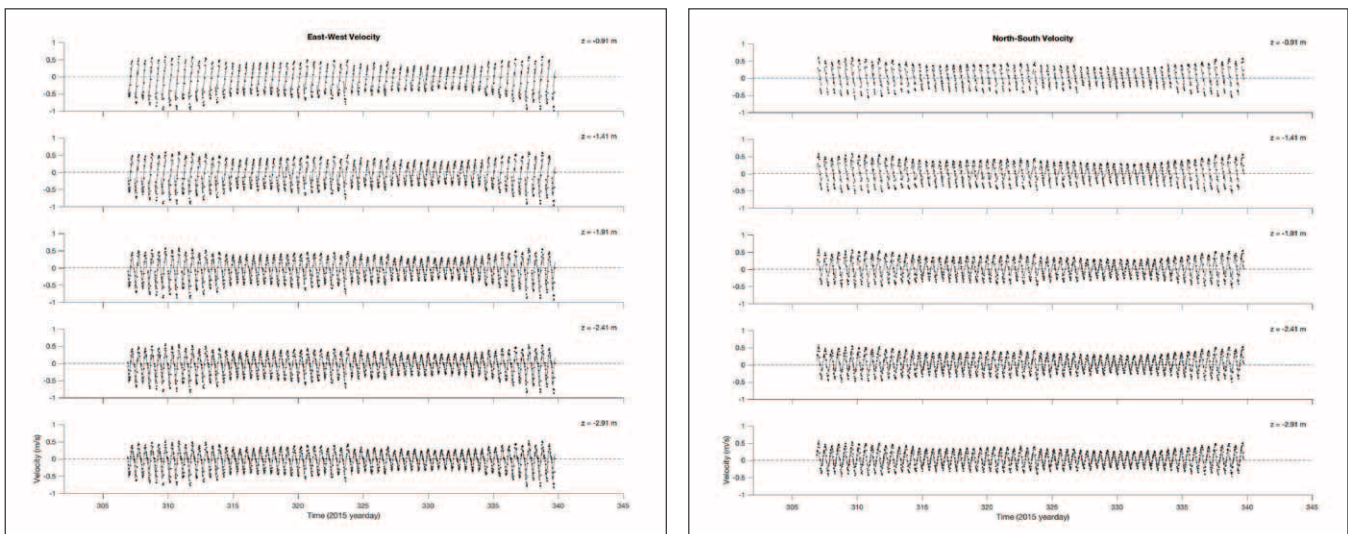

Figure 33-3. Modeled current velocities (solid lines) compared with observations (dots) at sensor located within the central part of Hampton Harbor. Elevation of the estimated or observed velocities is indicated in each panel relative to mean sea level. Left panels show east-west velocities. Right panels show north-south velocities.



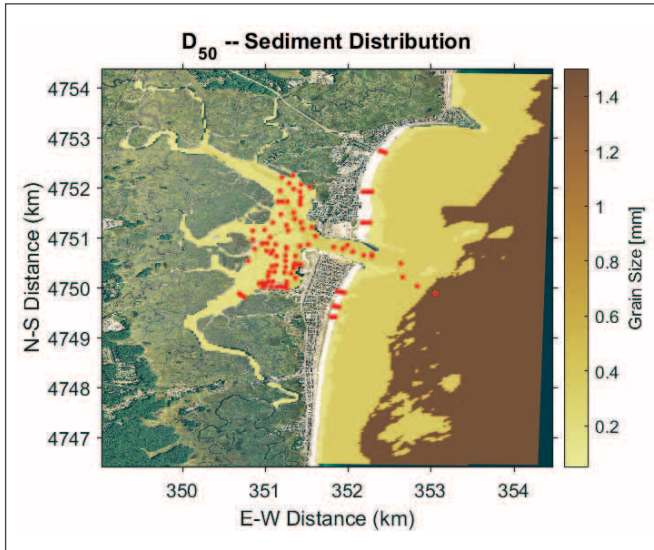

Figure 33-4. Hampton/Seabrook Harbor showing the location of sediment samples (red dots) obtained from 2000-2015 and used to develop the sediment size distribution for the model grid.

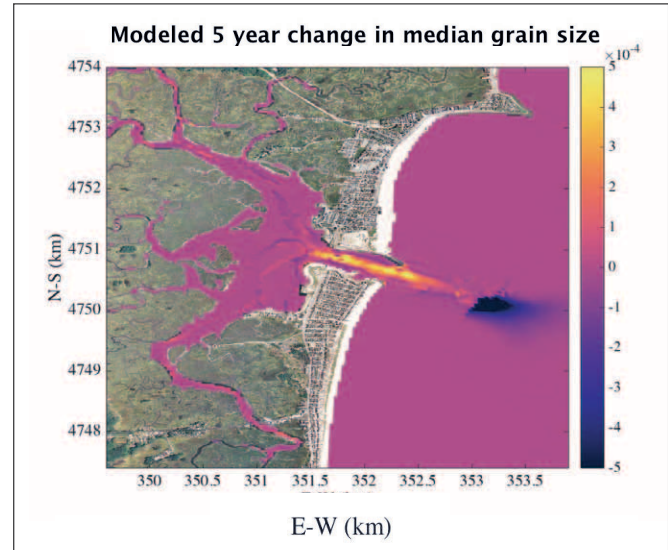

Figure 33-5. Change in median grain size distribution after the five-year model run.

For each grain size, settling velocity (based on the assumed quartz sediment) and critical shear stresses were determined. Using the four determined grain sizes, a sediment grid was created for use in the numerical model (Figure 33-4). Our efforts are focused on gross relationships between observed grain size distribution and water depth, with coarser grain sizes in the deeper, more energetic channels, and progressively finer grain sizes as the depths shallow and the

flows weaken (Figure 33-4). The grid includes a bed thickness of 5 m (i.e., the amount of material that can be eroded in the model). To properly account for a surface piercing jetty on the north side of Hampton Inlet, for the half-tide jetty on the south side of the inlet, and two submerged bulkhead revetments within the south side of the harbor, a fifth sediment class was defined with high critical shear stress to eliminate any erosion of the hardened structures. We have also

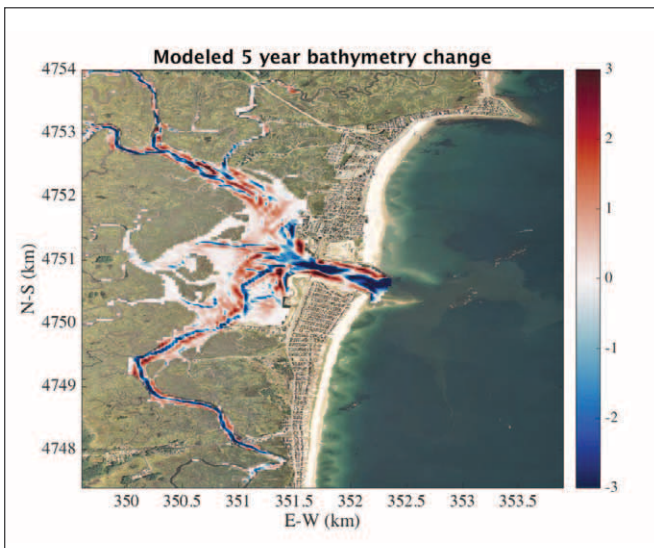

Figure 33-6. Bathymetric difference map from the five-year model run showing distribution of erosion and deposition.

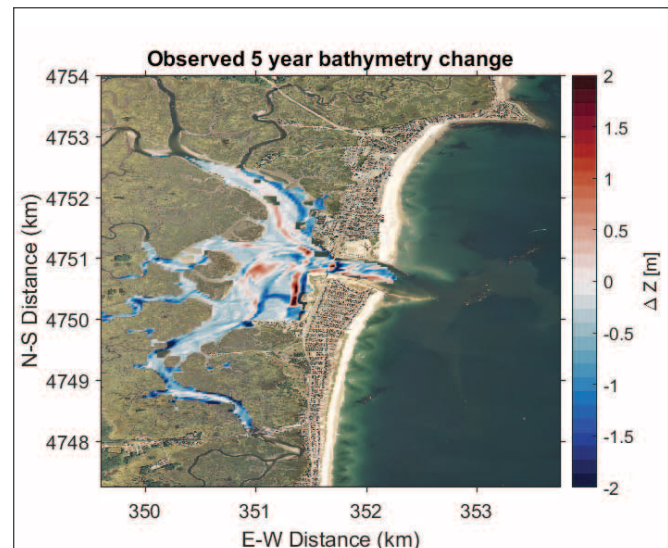

Figure 33-7. Observed bathymetric change from 2011 to 2016.





Figure 33-8. Aerial photograph of Hampton/Seabrook Harbor taken in 2017 showing the channel cuts across the middle ground (flood tidal delta) and infilling of the navigational channel leading to a large portion of New Hampshire's fishing fleet.

begun implementing the wave component (Simulating Waves Nearshore, or SWAN) in the model and have made measurements of waves offshore Hampton Inlet in preparation for including wave driven sediment transport on the nearshore areas adjacent to the inlet.

Previously (2017), to test the stability of the model with realistic forcing and sediment distribution, sediment transport runs for 16 days were conducted for the 3D (8-layer) model. Bedload transport was based on Meyer-Peter Mueller (1948) formulations for unidirectional flow, and suspended load based on solving advection-diffusion equations (Colella and Woodward, 1984; Liu et al., 1994) and setting velocities based on grain size and density of quartz and flocculation formulations based on mud with grain sizes specified in the smallest size fraction. In the past twelve months (2018) we have focused on conducting

long five-year model simulations. Figure 33-5 shows the changes in median grain size for a "typical" five-year run, and Figure 33-6 shows that bathymetric evolution.

Comparisons with the observed bathymetric changes are shown in Figure 33-7. Simulated changes to the bathymetric evolution occur within the inlet and back bay areas where the strongest flows exist and is consistent with the observations of the bathymetric evolution over the 5-year period. In particular, changes to the tidal channels across the middle ground (flood tidal delta) are correctly simulated, and the infilling of the navigational channel passing by the Yankee Fisherman's Coop is predicted. This infilling (shown in aerial photograph in Figure 33-8) has led to emergency dredging operations to clear the channel critical to the New Hampshire fishing fleet. Presently, boats are only able to enter or leave the harbor at higher

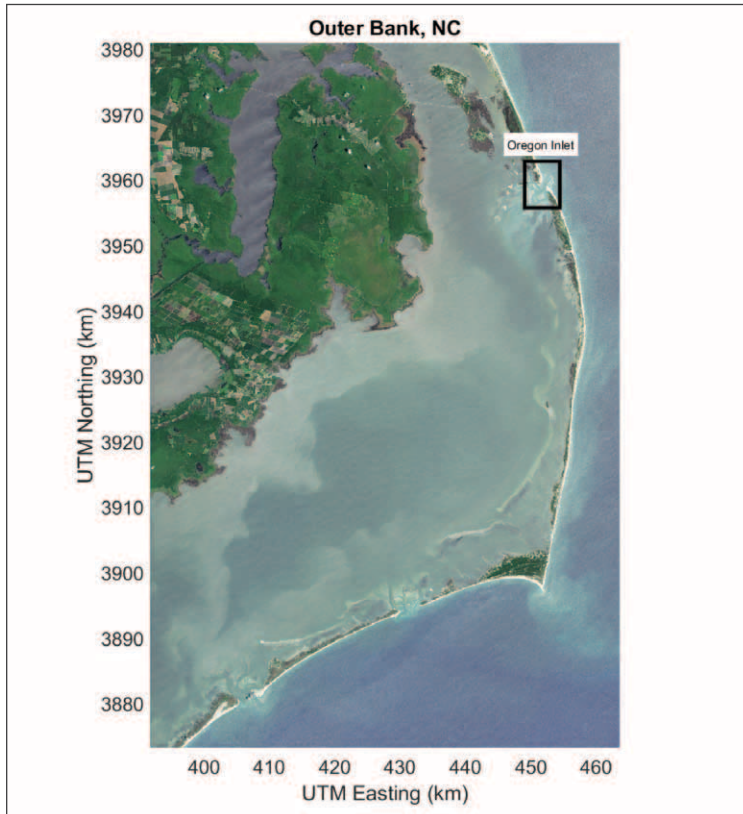

Figure 33-9. Location of Oregon Inlet along the Outer Banks of North Carolina.

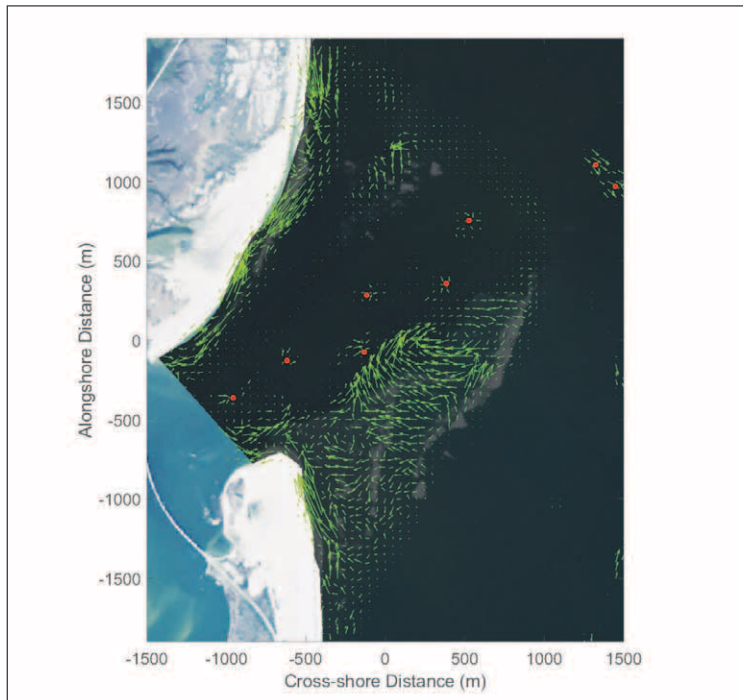

Figure 33-10. Average bedform and shoal migration patterns derived from RIOS observations using an optical motion tracking algorithm.

stands of the tide. The model reasonably well predicts the behavior observed and suggests that gross behavior of the bathymetric evolution in the Hampton/Seabrook Harbor could be forecast. Changes to the bathymetry over the five-year period can be compared with pre-defined allowable uncertainties in the bathymetric depth to identify when and where navigational areas are outside acceptable bounds and initiate action plans and direct mitigation or further reconnaissance efforts efficiently.

There are limitations to the model. In particular, the grid resolution is too coarse to properly define the behavior of sediment transport in the narrow upstream channels of the marsh, resulting in too much erosion of fine-grained sands and muds that are exported out of the inlet and deposited offshore (Figure 33-5). Grid refinement will be necessary to properly account for any changes further up the inlet. Because the fine grains are washed through the inlet, they do not appear to have a large effect on the sand transport in the harbor suggesting that even the coarse grid model (which runs significantly more efficiently than finer grid models) well represents the channel and shoal behavior in the harbor. A second limitation is the modeled inlet depth erosion which is more extreme than is observed. We believe this to be a problem with transverse slope effects that are under-predicted (a known problem for typical sediment transport formulations; Van Rijn, 2007). Fine grid scale models with modified transport formulations will be implemented in future simulations.

Ph.D. student Joshua Humberston, funded on a DOD SMART Fellowship and working under supervision of Lippmann and collaborator Dr. Jesse McNinch (USACE), is examining the bathymetric evolution and sediment transport pathways at Oregon Inlet, a large and dynamic navigational inlet located on the Outer Banks of North Carolina (Figure

33-9). This work pairs remote sensing data with numerical modeling to better understand sediment transport patterns and morphologic evolution directly influencing navigational safety. Observations were collected using the Radar Inlet Observing System (RIOS; McNinch et al., 2012) which quantifies the spatial morphological changes in regions where waves shoal and break on bathymetric shallows, sand bars, and beaches.

Application of an optical motion tracking algorithm to processed and averaged radar images has revealed complex but coherent patterns of bedform and shoal migration (Figure 33-10). These evolutionary patterns were considered in the context of strong sub-tidal variations at this location which frequently exceed tidal amplitudes and can differ significantly from the sound to ocean side of the inlet (Figure 33-11). This suggests sub-tidal components set up a residual pressure gradient across the inlet independent of astronomical tides. A simple comparison between the spatially and temporally averaged migration rates and direction and the sub-tidal gradient evinced a strong connection with a 0.72 correlation between the two time-series (Figure 33-12).

These observations are paired with ongoing numerical modeling efforts utilizing the Delft3D modeling system (Lesser et al., 2004). The model bathymetry is based on source data from lidar and bathymetric surveys conducted by NOAA, USGS, and USACE. The computational grid employs a nesting method to simulate hydrodynamics and waves over a large area at a resolution of 155 m and hydrodynamics, waves and sediment transport over a smaller area immediately surrounding the inlet at a resolution of about 11 m (Figure 33-13).

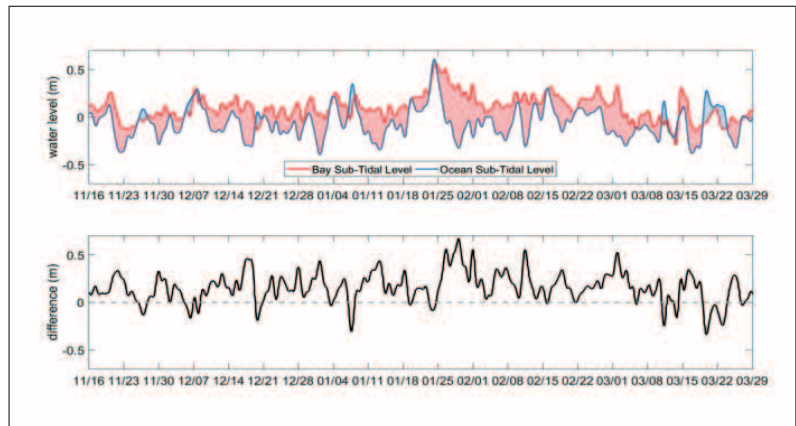

Figure 33-11. Differences in sub-tidal water level variations across the inlet create a dynamic residual pressure gradient which primarily forces a sound to ocean flow.

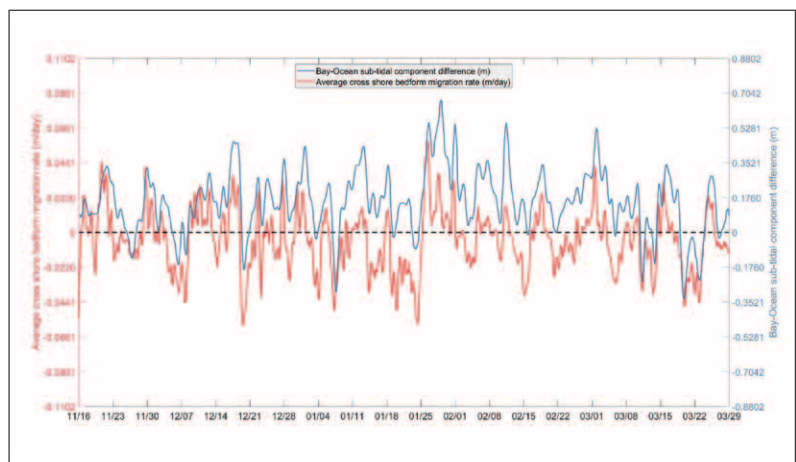

Figure 33-12. A strong connection exists between the sound-ocean sub-tidal water level difference and the sound-ocean shoal and bedform migration based on estimates from continuous radar observations.



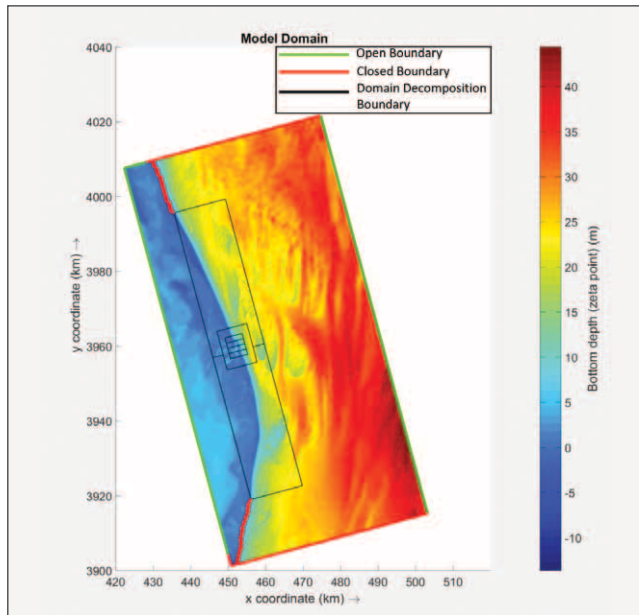

Figure 33-13. Spatial domain showing the nested grids used at Oregon Inlet to model waves, currents, water levels, and sediment transport with Delft3D.

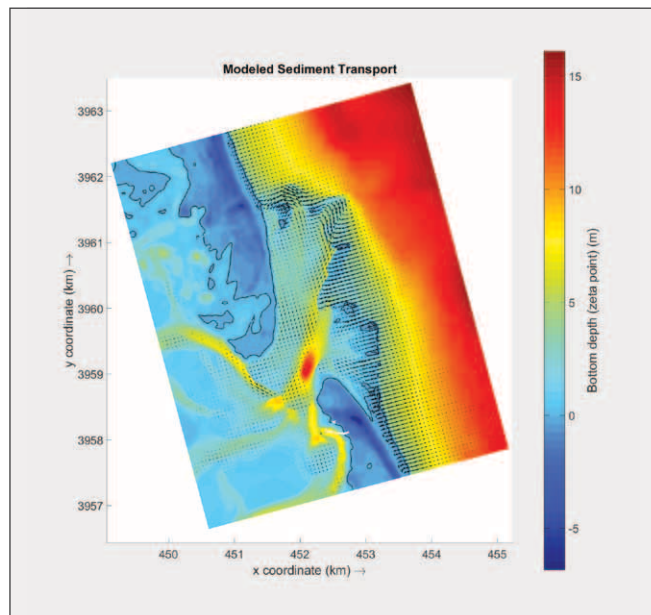

Figure 33-14. Preliminary model run showing the modeled currents and resulting bathymetry over a 30-day period at Oregon Inlet with Delft3D.

Nesting reduces the computational cost of simulations by permitting the finest grid to only be applied over the immediate area of interest while still allowing realistic wave and hydrodynamics conditions to evolve over a larger surrounding domain.

Figure 33-14 shows a preliminary model result with currents overlain on the resulting bathymetry after a 30-day simulation. The model is forced by time series of waves and water levels recorded by local wave buoys and tidal gauges, respectively.

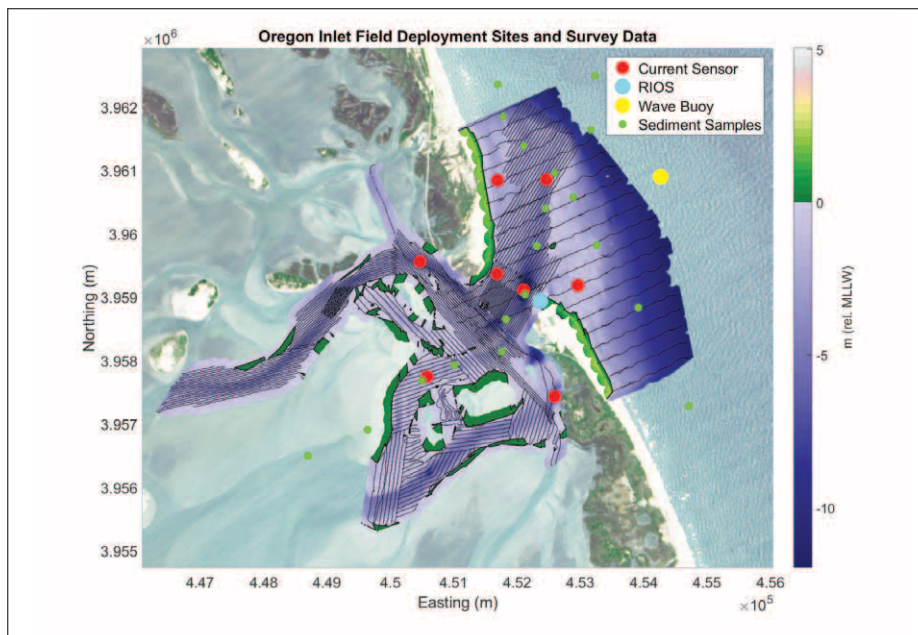

Figure 33-15. Map of Oregon Inlet showing the location of bottom mounted ADCP's (red circles), RIOS radar station (cyan circle), offshore wave buoy and pressure sensor (yellow circle), and sediment grab samples (green dots) deployed for 35 days in the winter of 2019. Single-beam bathymetric survey transect lines are shown with the black lines.

Together, these forces instigate sediment transport which is estimated using the transport model based on van Rijn (1993). Sediment bed characteristics are defined by a uniform 0.2 mm median grain diameter and porosity of 0.5 based on literature values (Larson, 1991; Larson et al., 1994; Bayram et al., 2001). During a field effort conducted this past winter we obtained observations of currents, water levels, and waves at 11 locations within the inlet, inner continental shelf, and back bay areas, as well as numerous sediment grab samples, to compare with model results (Figure 33-15). Also obtained by collaborators at the USACE (McNinch) were radar backscatter

images that show the position of the ebb tidal shoal complex and how it evolves in time (data that will be used to verify the sediment transport aspect of the model). Figure 33-16 shows an example radar backscatter image showing the position of the ebb tidal shoals in 2019 compared with similar observations from 2017 illustrating the dynamic nature of the inlet sediment transport. The focus of this work is presently on model verification with the obtained field observations. Verified simulations will predict sediment transport patterns with some skill and allow for examination of sediment pathways into, around, and through the inlet.

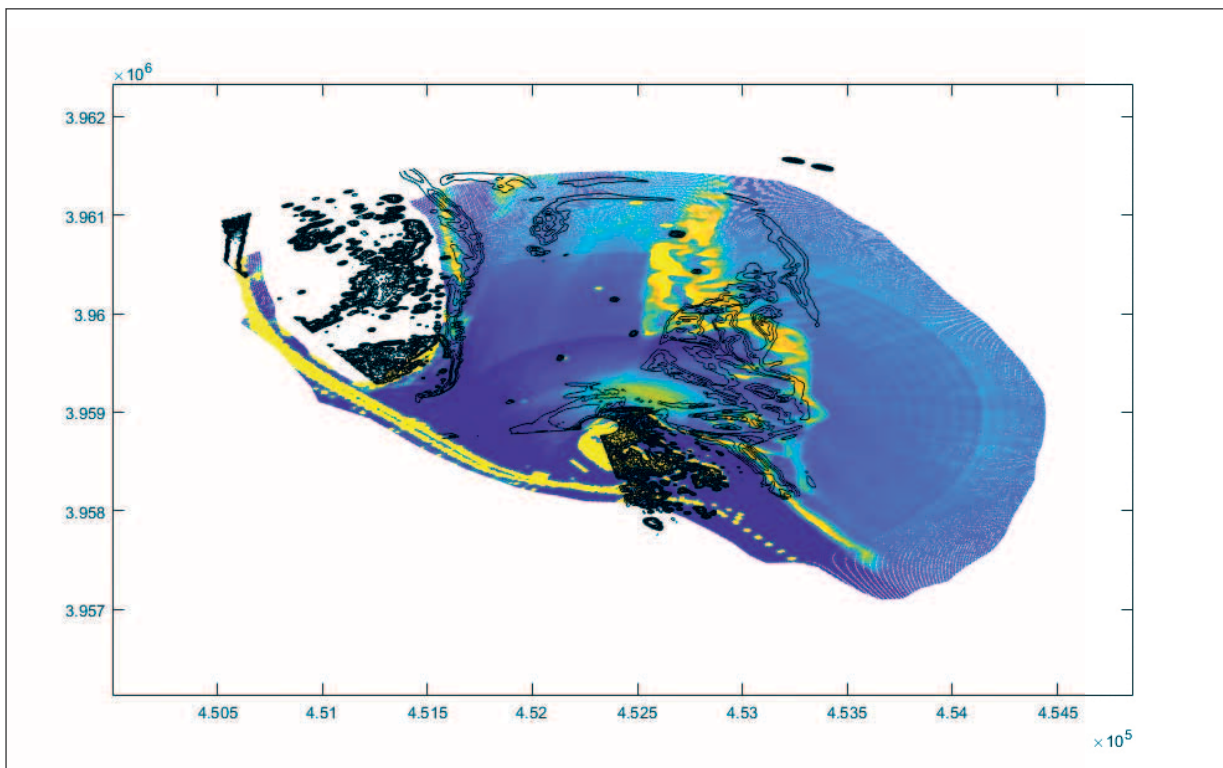

Figure 33-16. Map of Oregon Inlet showing the location of ebb tidal shoal patterns observed in the winter of 2019 (yellow areas) obtained with RIOS radar remote sensing. The black contour lines show the shoal positions observe 2 years previously in 2017 illustrating the dynamic nature of the inlet sedimentary system.

## Research Requirement 1.D: Third Party and Non-Traditional Data

**FFO Requirement 1.D:** “Development of improved tools and processes for assessment and efficient application to nautical charts and other hydrographic and ocean and coastal mapping products of data from both authoritative and non-traditional sources.”

### THEME: 1.D.1 Third Party Data

**TASK 34: Assessment of Quality of Third Party Data:** *Investigate methods for combining multiple repeated, or pseudo-repeated, measurements, as well as decision rules for what constitutes “sufficient” evidence to determine that the third-party data indicates that there are issues with existing hydrographic database or chart, and thus that action is required. Finally, we will also attempt to determine what sort of action is required (i.e., resurvey, update chart, etc.).* PI: **Brian Calder**

**JHC Participants:** Brian Calder and Shannon Hoy

**Other Collaborators:** Jennifer Jenks (NOAA NCEI); Sam Harper, Andy Talbot and Rob Andrew (UKHO)

The ocean is, fundamentally, large and survey boats are, usually, small. Consequently, irrespective of the effort expended in systematic, tightly controlled hydrographic surveys by an authoritative source, it is likely that limited resources will always preclude continually updated surveys of any country’s charting area of responsibility. With tightening budgets, there is more emphasis than ever on using all available sources of information on the bathymetry and non-bathymetric chartable objects to aid in the assessment, maintenance, and update of charts or other navigational products. While logical and fiscally prudent, this approach begs a number of difficult questions, particularly with respect to quality, reliability, and liability.

In previous reporting periods, the Center has examined segments of this problem, for example through the development of survey techniques based on satellite-derived bathymetry. In the current reporting period, the work has focused on understanding the liabilities associated with authoritative use of CSB, and on models for observer reliability. In addition, Calder provided advice to NOAA Navigation Managers on configuration of CSB devices for reliable data collection in Alaskan waters.

#### Project: Authoritative Use of CSB Data

Crowd-Sourced Bathymetry has become a popular topic for many hydrographers, with a number of organizations working on hardware and software to collect and manipulate such data (typically not for hydrographic purposes), and some hydrographic offices considering potential uses for such Volunteered

Geospatial Information (VGI) in their workflows. The International Hydrographic Organisation (IHO) have also chartered a working group to consider the topic (the first version of the report, B.12, being completed in early 2018). In much of this activity, however, the unwritten assumption is that if the data is collected, something useful will be done with it, and that the properties of a “crowd” (as is typically meant in crowd-sourced applications) applies to the hydrographic, or at least bathymetric, field. These assumptions do not appear to have been strongly tested.

Graduate student Shannon Hoy has been developing a thesis considering “The Viability of Crowdsourced Bathymetry,” and in particular has studied the make-up and capabilities of the potential crowd, and their attitudes to CSB collection. In the current reporting period, Hoy presented a section of this thesis at the U.S. Hydrographic Conference, taking (and demonstrating) the position that while CSB is currently unable to meet charting standards, and is therefore more suited for ancillary tasks (e.g., survey prioritization and change detection), hydrographic offices have a responsibility to report dangers to navigation to the mariner and, therefore, must incorporate CSB into the chart. Further, it was concluded that if any CSB data is used for the chart, all CSB data must be considered: picking and choosing among the data is not only time consuming, but problematic from a liability perspective. A spirited exchange of views on the conference floor demonstrated that this position is liable to be controversial for some time, despite the evidence, and that further socialization of the idea is likely to be required.



### Project: Data Logger Evaluation and Field Trial

Through a request from NOAA National Centers for Environmental Information, specifically the IHO Data Center for Digital Bathymetry, Calder, in collaboration with Jennifer Jencks (NOAA NCEI), has been investigating the field of data loggers available for CSB observations at scale. This request initiated with the GEBCO-Nippon Foundation Seabed 2030 Initiative, where CSB is seen as one of the tools to address the overall goal of mapping the entire world ocean by 2030.

The ultimate goal of the request is to provide data loggers, funded by Seabed 2030, to one or more areas around the world which suffer from limited data availability and assess how to operationalize CSB data collection at a scale that can make a positive impact on charting, or at least depth determination (see previous project), within the area. The implementation plan involves a development of the work carried out by Dr. Robin Beaman (James Cook University) in the Great Barrier Reef, which demonstrated the value of local contact personnel to drive/administer data collection, and feedback mechanisms to retain the recruited observers. The proximate question for this work, however, is: which logger or loggers?

Given the work of the IHO Crowdsourced Bathymetry Working Group (CSBWG), significant experience has been gained in capturing data through NMEA0183 serial data connections (typically a classical “\$SB-DBT” and “\$GPGGA” string combination), but less attention has been paid to the newer NMEA2000 standard, which uses the CAN (Controller Area Network) physical layer and signaling protocols, and is available on many pleasure craft which might be useful observers. The Center therefore conducted a survey of twelve available loggers (hardware and software), and then purchased (at retail value) a short-list of four systems for evaluation: three NMEA2000, and one NMEA0183. Evaluations were conducted by graduate student Dan Tauriello on the *R/V Gulf Surveyor*, and a series of recommendations were provided to NCEI and CSBWG. Based on this experience, and the feedback on the recommendations, the project is moving on to the implementation of a field collected experiment.

Calder and Jencks have therefore initiated discussions with the United Kingdom Hydrographic Office and South African Hydrographic Office about the potential to sponsor data collections in a remote area

within their charting region. The ultimate goal would be to provide a significant number of loggers to a given geographical area (thereby aiding in data density, and partially repeated observations, as outlined in the previous project) with infrastructure sufficient to support a significant observer population and support services (e.g., marine technicians to provide installation support), along with local support personnel to facilitate and monitor the data collection. The issue of local personnel is expected to be critical both to ensure consistency of data availability, and to maintain the population of volunteer observers. Initial target areas have been identified, and preliminary discussions with local organizations and potential support networks (including the GEBCO-Nippon Foundation Scholars) are on-going.

One question about the viability of scaling the CSB experience is cost: the data loggers tested typically retail at approximately \$250 (2019), which is a significant expense if widespread collection is the goal. The experience of a number of CSB-like initiatives has been that users are rarely, if ever, willing to pay for hardware solely to collect data; the only commercially viable collection efforts have proven to be “closed garden” initiatives where one company collects data from all users, aggregates it, and provides it back to the users, or where it is a side-effect of another application (e.g., an ECS). Notably, collection for contribution to an international database has not been a successful fiscal offering for users. It is likely, therefore, that for successful scaling, the hardware is going to have to be provided gratis and therefore the question becomes: what is the cheapest minimally viable data collection instrument?

To investigate this, Calder, in collaboration with a team of Computer Science undergraduate seniors, has begun a prototype design for a hardware and software solution with the explicit goal of minimizing cost while easing data flow to DCDB and thereby reducing barriers to entry. A proof-of-concept hardware design has been implemented, and is currently undergoing test. A rough-order-of-magnitude cost for production currently stands at approximately \$30 (2019) for either NMEA0183 or NMEA2000 logging, and approximately \$40 (2019) for both, although these costs would be expected to decrease, potentially significantly, if small production runs (e.g., 50-100 units) were conducted, due to economies of scale in component purchasing. In addition, the software portion, including wireless data offload from the

logger, aggregated transmission to a cloud-based processing center, cloud-native data processing, and automated upload to DCDB, is being developed by the student collaborators, with assistance from DCDB developers. Hosting costs are expected to be relatively low, since the data mainly flows through the cloud, rather than being resident for extended periods of time, and the cloud-provider matches DCDB requirement (i.e., no out-transfer of data is expected). An end-to-end demonstration of the whole system is expected in the first half of 2020, and the project has already attracted the interest of Industrial Partners willing to license and implement the technology developed.

## Project: Observer Credibility

A significant problem with the CSB model is that the observers are, essentially, unreliable narrators in the sense that, contrary to typical data processing problems in hydrography, the data biases (deterministic uncertainty) may be considerably higher than the data variance (stochastic uncertainty). In practice, this means that the depths available from CSB observers might be significantly shoaler (or deeper) than the true depth in a way that is difficult to ascertain from the data itself. Combining data like this is also prob-

lematic, since most estimation techniques assume that any biases have been removed before combination.

The commonly cited alternative to using the depth data directly is to suggest that the data might be used indirectly for change detection and resurvey assessment. That is, although the depths might be unreliable, repeated indications of difference between the authoritative data and CSB data might indicate that resurvey is required. While this line of reasoning is plausible, it is also subjective: how much evidence is required from the CSB data to declare that an intervention is required?

As a structuring concept for this problem, Calder has been investigating the potential for an assessment of the credibility of observers. Not limited to CSB observers, Figure 34-1, assessing the credibility of all observers allows both observers and their data to be placed on a spectrum between authoritative and random. Doing so provides a mechanism to answer many of the questions as to use of the data. For example, observations from credible (although not authoritative) observers would have greater probative weight when assessing archive data for change, meaning that fewer observations that disagree with

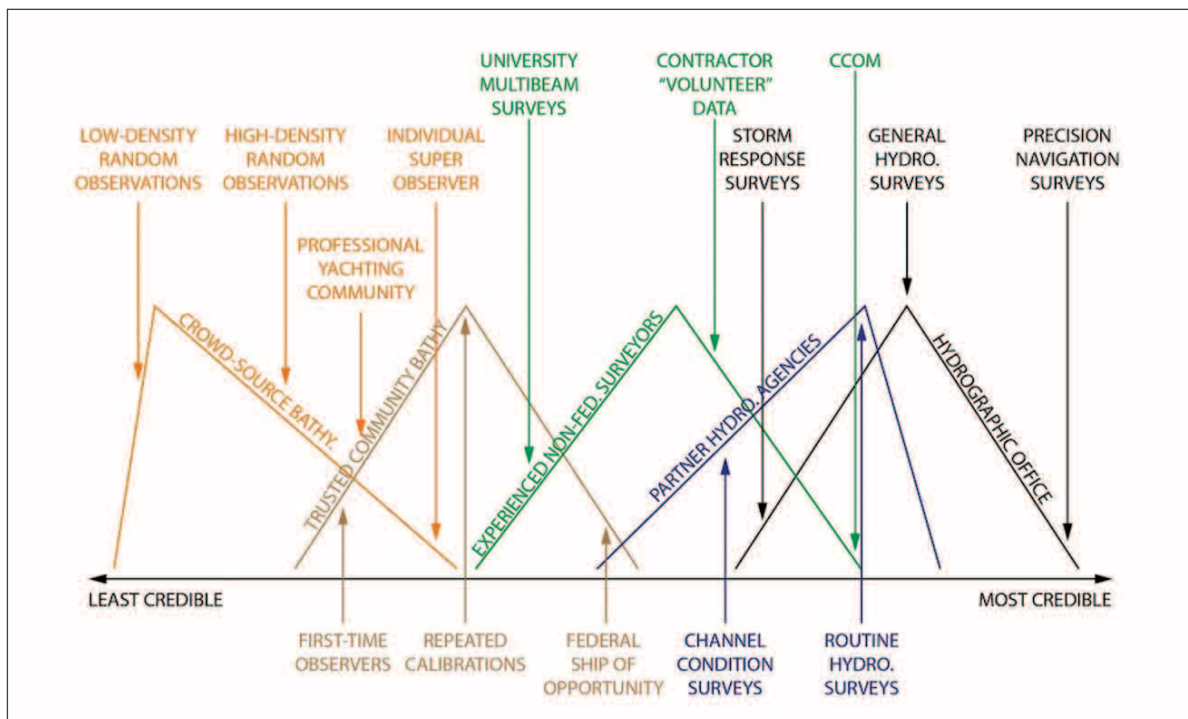

Figure 34-1. Conceptual model for the assessment of observer credibility. All observers are assessed on the credibility spectrum, shown here with plausible ranges for various communities and height indicating relative proportions of the community at each credibility rating. See Task 12 for information on Trusted Community Bathymetry.

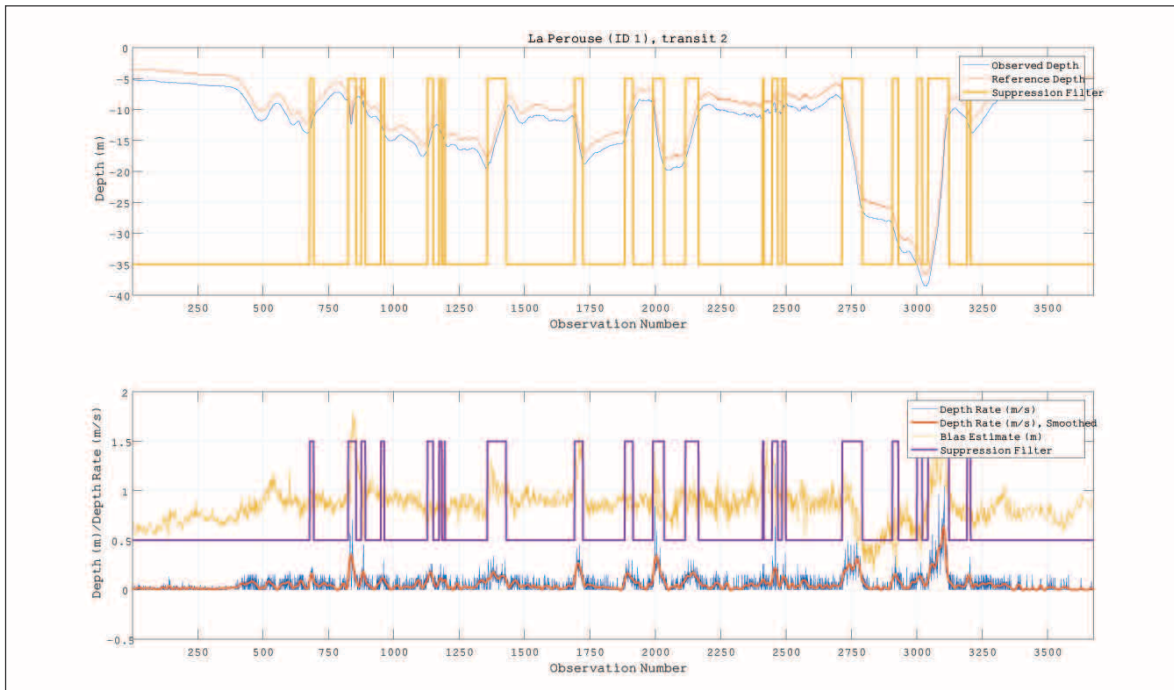

Figure 34-2. Example of observer ranking determination for biased and unbiased simulated observers compared against a static reference depth (10m). Observer uncertainty 0.30m, reference uncertainty 0.1m, reference observer ranking (2800, 30). Observations are batched in groups of 10, and observers are initialized with neutral ranking of (1500, 350).

the archive would be required to trigger an intervention. Similarly, since archive data inherits the credibility of its observer at observation time (but may subsequently diverge), modelling of the change in credibility as a function of time could be used to decay archive data until even a low credibility observation would be considered acceptable for use.

As indicated in Figure 34-1, it is expected that each community within the survey enterprise will have a spread of credibility levels, and that certain products within a given observer community might be of higher credibility than others. Thus, for example, surveys conducted for Precision Navigation (i.e., real-time under-keel clearance management for large-draft vessels) might be conducted to such a high tolerance that they are considered significantly more credible than routine survey efforts. In addition, it is necessarily the case that credibility is a dynamic process. Observers that demonstrate over time that they repeatedly report the same depth as a more credible (typically authoritative) source should be considered more credible (e.g., the "super observers" in Figure 34-1) and have their rating increased, while those that regularly demonstrate a bias with respect to credible (typically authoritative) sources should have their credibility rating reduced. Note that the model is blind to the community, so

even authoritative observers might have their credibility reduced if the results of survey do not match other observers. The same model obviously applies to data: once the data is committed to the archive, with the credibility rating of its observer, differences in depth indicated by credible observers would reduce the credibility, while confirmatory depth matches would reinforce the credibility of the data, potentially allowing older data to be maintained in the archive for longer.

The mechanism to implement this model is the subject of current effort, where investigation has started with chess ranking systems, such as those due to Elo and Glickman. These systems allow for paired observation comparison (e.g., observer against reference depths), and are designed to adjust ranking and (in Glickman's model) rank uncertainty over time as observers generate data (in the original context, as games of chess are played and scored). If we consider the comparison of a batch of observations from a CSB observer as "wins" if they agree with the reference where it exists (i.e., authoritative data that may occasionally be available in the same place), and "losses" if not, then Glickman's method can be used to adjust observer rankings (Figure 34-2). This mechanism allows the observers to start with a neutral mid-range



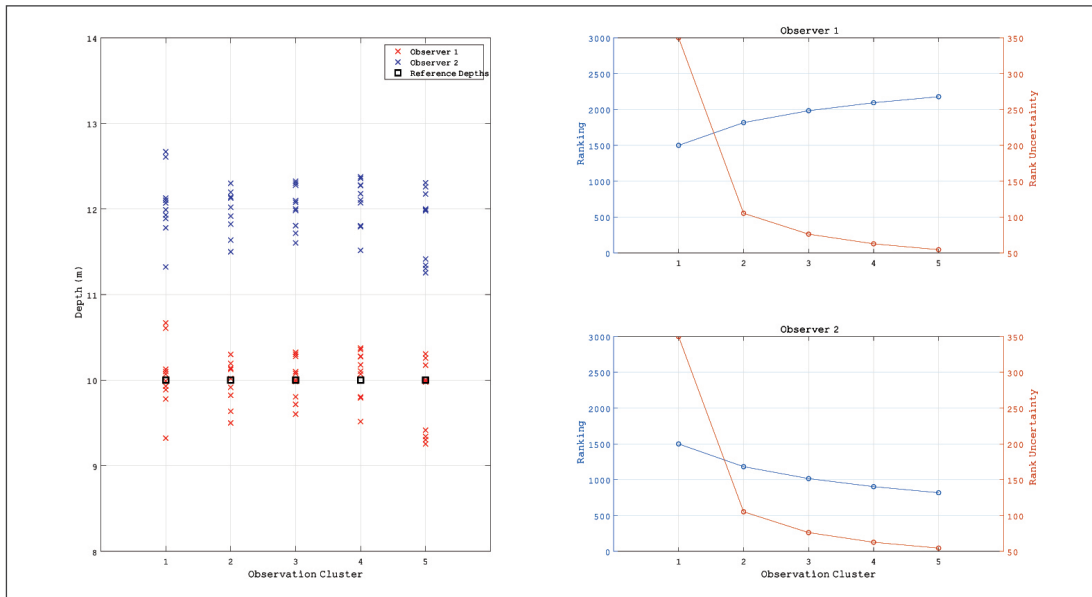

Figure 34-3. Example of volunteered data from the Puget Sound, WA region processed by the tools under development. The data represents one transit of the observer through the region (automatically detected), and reference data from NOAA hydrographic surveys in the region, along with the difference (i.e., the depth-dependent bias), rates of change of depth, and a slope suppression filter. Significant clean-up effort is required to make the data suitable for use.

ranking (1500 in this case) with high uncertainty (350), and then track to its natural level over time, which corresponds to drift up and down the axis in Figure 34-1. Importantly, the mechanism allows the observers to start with uncertain ranking, and adjust the estimate of certainty as more data become available, and allows for rankings to increase in uncertainty if they have not been updated recently (e.g., if the observer disappears for a while), and to vary in time (e.g., if a once-good observer starts to generate bad data). Clearly, this mechanism meets many, if not most, of the requirements outlined previously. Usefully, the algorithms being adapted are peer reviewed, allow for parameter estimation from prior data, and are mathematically tractable for large datasets.

One limitation of the current model, however, is that it is impossible to detect the cause of a bias, only that the bias has occurred. An unbiased observer compared against reference depths that have changed since they were recorded, therefore, would lose ranking, rather than adjusting the reference data's own reputation, ultimately leading to it being removed from consideration (i.e., the charted data is obsoleted in favor of any reliable observation). This can in part be ameliorated by running two separate rankings, one for observers assuming a static reference, and one for the reference (with different scoring rules). Detection, and potentially correction, of observer bias would, however, be a better solution.

Given sufficient data, this should be possible. Calder has therefore, in conjunction with IHO DCDB at NOAA NCEI, started work on data clean-up and estimation tools for CSB data, with the DCDB CSB data for the Puget Sound, WA region as the test set. This was selected because it has higher than average data density, a reasonable depth range, and good high-resolution survey coverage in the national archives.

This investigation has brought to light many of the issues with volunteered data, including corrupted depth, timestamps, and positions; inconsistent observers; and data biases. The tools being built, however, can resolve many of these automatically, with the understanding that this is a "big data" proposition, so that subsets of data that are believed to be reliable can be extracted for analysis, rather than attempting to analyze all of the available observations. By way of example, Figure 34-3 shows data from the Puget Sound, WA area where the code has extracted the top five most likely "useful" observers (based on an analysis of their available data), removed obvious outliers, matched the data against NOAA reference surfaces, corrected for water level, detected and extracted individual transit events, picked and removed regions where high slopes make estimation difficult due to echosounder beamwidths, and then computed the depth-dependent difference between observed and reference data in order to estimate the bias of the observer.

## Programmatic Priority 2: Transform Charting and Navigation

### Research Requirement 2.A: Chart Adequacy and Computer-Assisted Cartography

**FFO Requirement 2.A:** “Development of improved methods for managing hydrographic data and transforming hydrographic data and data in enterprise GIS databases to electronic navigational charts and other operational navigation products. New approaches for the application of GIS and spatial data technology to hydrographic, ocean, and coastal mapping, and nautical charting processes and products.”

**TASK 37: Managing Hydrographic Data and Automated Cartography:** *Investigate algorithms for the appropriate interpolation of data from sparse sources for use in populating a single-source database product, and to combine these products in a consistent and objective manner so as to provide, on demand, the best available data for the area, with associated uncertainty. Investigate methods for rasterization of vector product charts that better reflect the “style” of the current printed chart and develop methods to tackle the generalization problem for nautical cartography using both gridded bathymetric source and vector products for other chart components, with the ultimate goal of providing a vector product that can be rasterized at any given scale and still reflect the “style” of current charts. PIs: **Brian Calder and Christos Kastrisios***

**JHC Participants:** Brian Calder, Christos Kastrisios, Paul Johnson, Juliet Kinney, Michael Bogonko, and Sara Wolfskehl

**Other Collaborators:** Edward Owens (NOAA AHB); Olivia Hauser, Peter Holmberg, and Grant Froelich (NOAA PHB); Megan Barlett and Brian Martinez (NOAA MCD)

A long-term goal of many hydrographic agencies is to automatically construct cartographic products from a single-source database populated with a consistent representation of all available data at the highest possible resolution; in many cases, the goal is to populate with gridded data products. Such an approach has the potential to radically improve throughput of data to the end user, with more robust, quantitative, methods, and to improve the ability of charting data to be manipulated much closer to the point of use.

The primary problems in achieving this goal are the development of methods to populate the database and maintain its consistency; and methods to generate cartographic products reliably from the database that are acceptable to human cartographers for depiction in a chart product.

Creating a fully-gridded database is nominally simple; in practice, however, legacy sparse data, high-volume modern data, and the logic of how to splice together overlapping datasets make the practice much more challenging. Although many of the issues, such as the requirement for an uncertainty value associated with the depths, are understood,

there are many subtle interactions with the data that are hard to foresee directly. It seems likely, therefore, that the only way to truly understand all of the issues is to build an example database and examine the interactions directly in practice.

While many advances have been made, nautical cartography still requires the manipulation of massive data sets, the process of which is often monotonous, time consuming, and prone to human error. Tasks performed manually for years by cartographers have been described algorithmically and implemented in software environments, but while automation has facilitated the cartographers’ work, many of the existing algorithms fail to implement cartographic practices in their entirety and, thus, they do not perform consistently and satisfactorily in every geographic situation. Moreover, when cartographic products are automatically generated, they are often judged as crude, or unsuitable, by experienced cartographers. Therefore, in addition to improved tools with more geographic robustness, it is essential to understand the characteristics of current charts in order to determine what it is that cartographers look for in a final product.

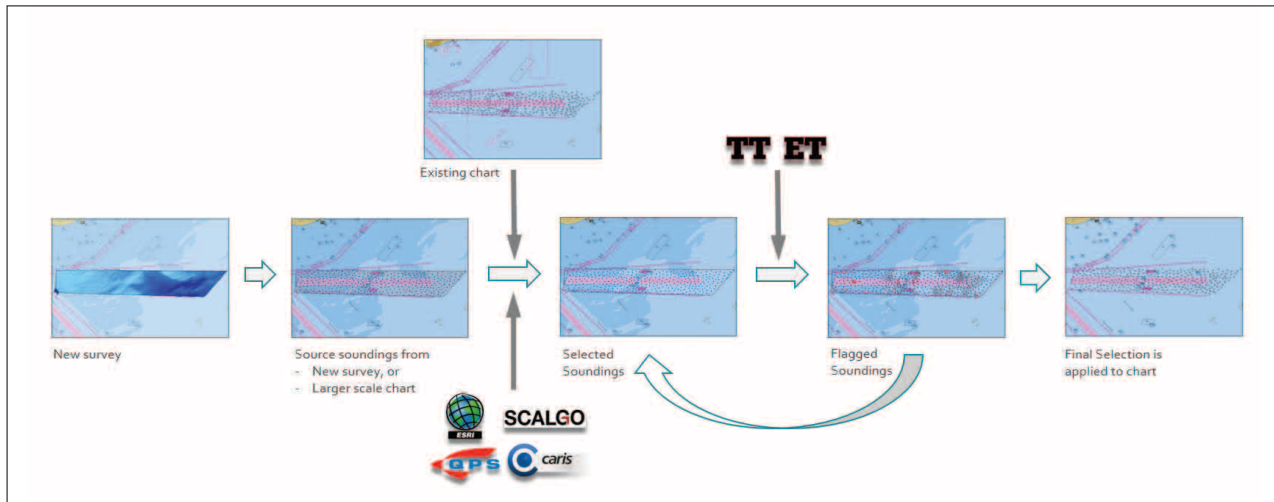

Figure 37-1. Process for turning source information into charted soundings.

**Project: Sounding Selection Verification Methods**

Depth curves and soundings are two of the most important features on nautical charts which are used for the representation of submarine relief. The charted depth curves and soundings are derived from more detailed (source) datasets, either survey data and/or larger scale charts, through generalization. The process is a continuous compromise among the chart legibility, topology, morphology, and safety constraints as they are often incompatible with each other. Once depth curves are created, the cartographer, following established cartographic practice rules, makes the selection of the soundings that will be charted. The selection (as well as the depth curves' compilation) is performed either fully manually and/or with using one of the existing software solutions, Figure 37-1. For manual selection, the cartographer first selects the least depths, critical, controlling, and supporting soundings, and subsequently the other soundings necessary for the representation of the seabed morphology on the chart. When a chart already exists in the area, the cartographer uses the distribution of soundings on the existing chart as a guiding subset for the selection of the additional soundings. The initial selection is then evaluated and corrected where necessary to meet the fundamental constraint of safety, i.e., that the expected water depth based on the charted bathymetric information should not appear, at any location, deeper than the source information. According to the IHO S-4 Chart Specifications, the "shoal-biased pattern" of selection for the charted soundings is achieved through the "triangular method of selection", and more specifically through two tests, known as the *Triangle* and

*Edge Tests* (TT and ET in Figure 37-1). For the triangle test the cartographer is called upon to verify that no actual (source) sounding exists within a triangle of selected soundings which is shoaler than the least depth of the soundings forming the triangle. Likewise, for the edge test, no source sounding may exist between two adjacent selected soundings shoaler than the least of the two selected soundings forming an edge of the triangle.

In previous reporting periods, Christos Kastrisios, Brian Calder, and Giuseppe Masetti, in collaboration with Pete Holmberg (NOAA PHB) and Brian Martinez (NOAA MCD), developed an algorithmic implementation of the triangle test with increased performance near and within depth curves and coastlines, and the first automated implementation of the edge test described in the literature. The work showed the significance of the edge test in the validation process, where it may identify shoals that the triangle test fails to identify. The two implementations, in addition to the selected soundings, incorporate the available bathymetric information on charts in the form of points and lines (e.g., rocks, depth curves, and coastlines), and (to account for the areas near the boundaries of the new survey) the charted bathymetric information from the adjoining areas for the generation of a conforming Delaunay triangulation.

The research work documented individual limitations of the triangle and edge tests, and revealed a fundamental, "intrinsic," limitation of the two tests that prevents the construction of a fully automated solution based solely on them. The fundamental limitation is considered "intrinsic" because it is the



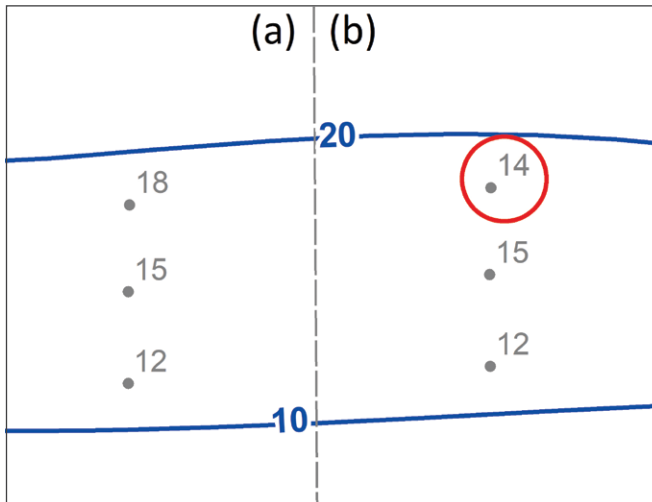

Figure 37-2. Source sounding (14m) that deviates significantly from the expected depth, but which the triangle and edge tests fail to identify due to their intrinsic limitation.

result of the definition of the two tests as described in the IHO S-4 publication and is thus independent of any particular implementation.

To illustrate the intrinsic limitation, Figure 37-2 presents two depth curves (10m and 20m) and source soundings between the two. On the left side of the dividing line (Figure 37-2(a)), the values of the source soundings follow a distribution that a user might expect between the portrayed depth curves. On the right side of the dividing line (Figure 37-2(b)), the 14m sounding is approximately 20% shoaler than the expected depth at the specific location (based on the configuration of the two curves), and, as such, should be brought to the cartographer’s attention for evaluation. However, the two tests fail to detect the specific discrepancy because (according to the tests’ definition) the source information is compared to the least of the two or three vertices forming an edge or triangle. In this specific example, for all vertices forming triangles and edges from the depth curves 10m and 20m, the comparison depth is 10m.

In practice, the two tests generate a rough approximation of the surface represented by the charted bathymetric

information using a gridding approach with an enormously big element. Each element is assigned the depth value of the shoalest of the two or three vertices forming the edge or triangle respectively and is compared to all source soundings within the specific element for the validation process. To illustrate this, Figure 37-3 presents a profile view of the seabed based on the available source information (brown dotted line in Figure 37-3) and the Delaunay faces (red lines in Figure 37-3) generated from the selected soundings (blue points in Figure 37-3). The horizontal dashed lines represent the vertical section of the discussed elements that serve as the validation depth for identifying the areas violating the safety constraint. With this approach, the eminences crossing the horizontal dashed lines are flagged (e.g., shoal “B” in Figure 37-3), but anything below the validation depth is not (“A” and “C” in Figure 37-3), even if it deviates significantly from the expected depth in the area (e.g., the shoal marked “A” in Figure 37-3).

Clearly, a better test mechanism is required. therefore, in the current reporting period, a new surface-based test was proposed, investigated, and developed, termed the Nautical Surface Test (NST), or surface-test” (ST) for short. This method accounts for the configuration of the seabed at the appropriate charting resolution and captures the relevant discrepancies between the source and the selected bathymetric information for charting.

Unlike the triangle and edge test where the source information is compared against a distant depth

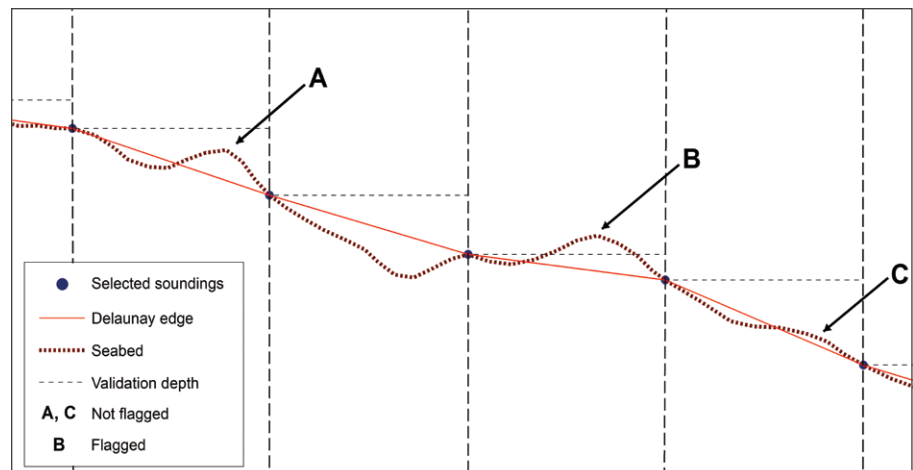

Figure 37-3. A profile view of the seabed, the selected soundings, and the Delaunay faces showing why the two tests fail to identify eminences that deviate significantly from the expected depth on chart.

value because it happens to be the shoalest of the two or three depth vertices forming an edge or triangle (with the subsequent problems presented above), for the Nautical Surface Test the source soundings are compared to the “expected” depth at the exact location of the source soundings. For each source sounding, the surface test interpolates the charted bathymetric information and compares the calculated value to the depth value of the source sounding. If the former is greater (meaning that the depth at this location appears deeper than the measured depth), the source sounding is flagged. There are several interpolation methods described in the literature (e.g., Linear Interpolation, Natural Neighbors, Inverse Distance Weighting, Kriging, Spline) that may be used with the described test, each of them with advantages and disadvantages. Currently, the developed implementations of the surface test incorporate the Delaunay triangulation with Linear Interpolation (“NST-L”) and the Natural Neighbors (“NST-N”), but which interpolation method performs best for the bathymetric information on charts (including how bathymetry is perceived by mariners and cartographers) is an open research question.

Figures 37-4–6 present the results of the surface test (and more precisely the NST-L) and the two traditional tests (triangle and edge tests) in two geographic situations, demonstrating the superiority of the NST-L. In these figures, the selected soundings appear in blue, the source soundings in light grey, the soundings flagged with the traditional tests in black and those flagged with the NST-L in dark grey. In Figure 37-4, for the traditional two tests all source sound-

ings within the northern triangle are compared to the 21.9m selected sounding and those in the southern triangle are compared to 23.1m. The two tests identified as shoal only the 21.8m source sounding in black. Clearly, 0.1m depth difference at the location of the 21.8m is insignificant compared to the 21.9m selected sounding and, thus, the 21.8m flag may be ignored. If one were to rely on these tests, one might draw the conclusion that the current selection of soundings honors the safety constraint and that the area in question passes the validation test.

On the contrary, the NST-L results in Figure 37-5 illustrate that the current selection of soundings in the area is problematic. Particularly, the source soundings emphasized in Figure 37-5 (i.e., soundings portrayed in dark grey, orange, and red) are source soundings that are shoaler than the interpolated depth at the specific location and, consequently, flagged by the surface test. As for the 21.8 m sounding in Figure 37-4, the flagged soundings in Figure 37-5 may also be insignificant, but one of the advantages of the surface test is that a tolerance may be applied to the identified shoals. It seems reasonable that the tolerance (i.e., the maximum value that the calculated depth may be deeper than the source sounding) for the surface test should derive from the Zone of Confidence (ZOC) value in the area. The specific area of Figures 37-4 and 37-5 are assigned ZOC A1, meaning that the acceptable depth accuracy is 0.5m + one percent of the depth (roughly, 0.75m). By applying the tolerance to the above results, all the soundings in dark grey are within the acceptable A1 limits and can be ignored. However, at the location of the sounding in

orange the expected depth exceeds the allowable limit of depth accuracy for A1 and falls within ZOC A2 limits (up to 1m + two percent of the depth), and at the location of the two soundings in red exceeds the A2 limits and falls within ZOC C (up to 2m + five percent of the depth).

The utilization of depth tolerance, as shown in the previous example, helps to

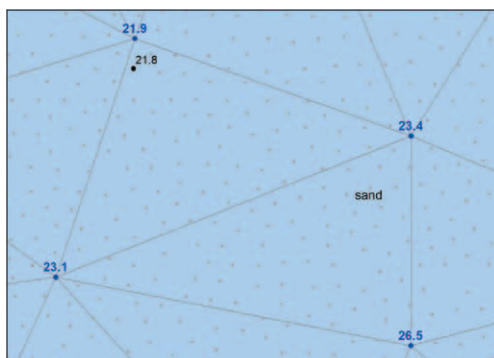

Figure 37-4. Example of conventional selected sounding testing. With only the 21.8m source sounding flagged through the triangle and edge tests, one may conclude that the area enclosed by the two triangles meets the safety constraint.

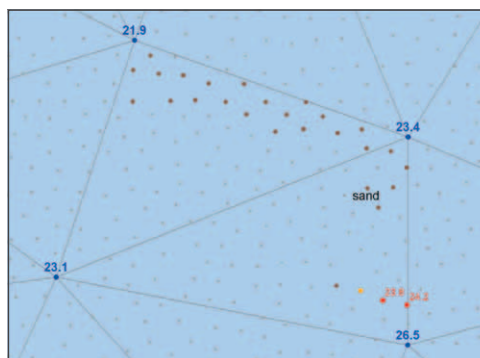

Figure 37-5. Example of the proposal nautical surface test. The NST identified multiple locations where the expected depth is deeper than the source information. Those in dark grey fall within ZOC A1 limits and may be ignored, that in orange falls within A2, and, worse, those in red would fall within ZOC C.

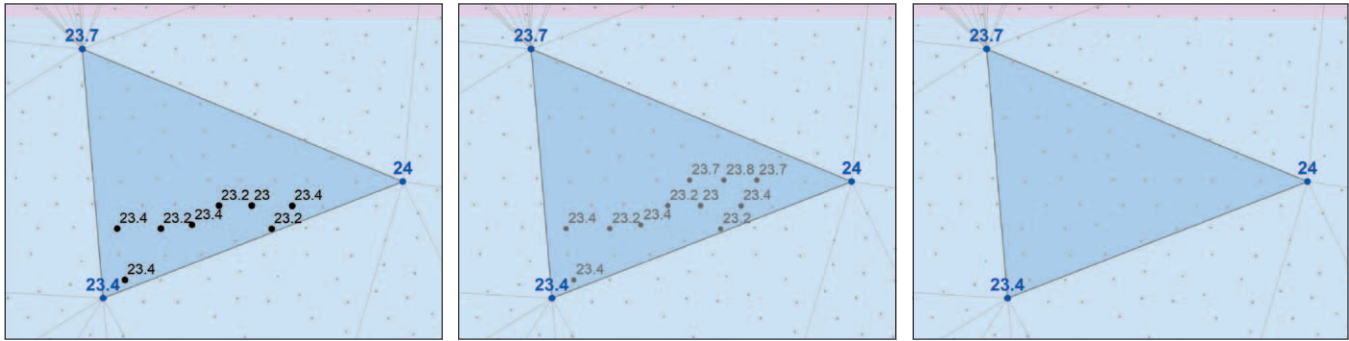

Figure 37-6. Example of filtering detections from the NST using surface uncertainty tolerances to reduce inspection effort. (a) The soundings flagged with the triangle and edge tests, (b) Soundings flagged with the surface test, (c) The results of the surface test after the ZOC A1 tolerance is applied.

distinguish the significant from insignificant detection and it is an important advantage of the surface test over the triangle and edge tests; use of a tolerance value with the traditional two tests would make them behave unpredictably. To elaborate, applying a 0.1m tolerance to 37-4 would result in eliminating the insignificant 21.8m shoal. However, if the 14m sounding right next to the 20m depth curve in Figure 37-2 was 9.9m, with the 0.1m tolerance it would also be removed although it would constitute a significant shoal and potential danger to navigation. Figure 37-6 illustrates a characteristic example of a situation where the triangle and edge tests flagged eight source soundings and the NST-L flagged 11 source soundings (including the eight flagged previously) in the triangle formed by the three selected soundings. The soundings flagged with conventional methods need to be inspected by the cartographer, whereas with the NST and 0.1m tolerance all 11 shoals can be automatically removed.

The triangle test and the edge test often result in an enormous number of insignificant shoals, but as explained previously, it is unsafe to apply any form of tolerance to the two tests. The surface test, in conjunction with an applied tolerance value, helps cartographers by removing the less significant shoals, thus preventing an error-prone "cluttered" situation where the cartographer may fail to identify the significant shoals and properly improve the soundings selection.

The research effort has led to a toolset consisting of the triangle, edge, and surface tests that is in the process of becoming operational with NOAA/OCS Marine Chart Division. In this context the team has been working on making modifications/

improvements to meet the compilation requirements. For instance, HSD and USACE deliverables may be utilized by the tools, flexibility on the spatial reference of inputs has been added, the performance of the tools has been significantly improved, and cartographic visualization techniques have been applied to the exported results to help cartographers focus on the most significant shoals. Specifically, the soundings flagged by the triangle and edge tests are visualized with a variation in color value for the percentage of depth difference between the flagged sounding and the reference depth. For those flagged by the surface test, a bivariate visualization is utilized with variation in color hues for the different ZOC levels and in symbol size for the percentage of depth difference between the flagged sounding and the interpolated depth at the location (Figure 37-7).

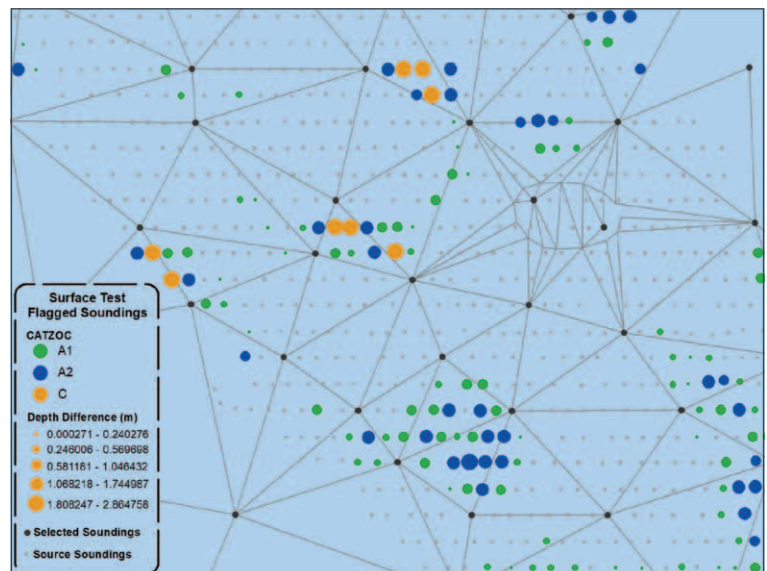

Figure 37-7. Soundings flagged by the nautical surface test tool that is being tested by MCD.



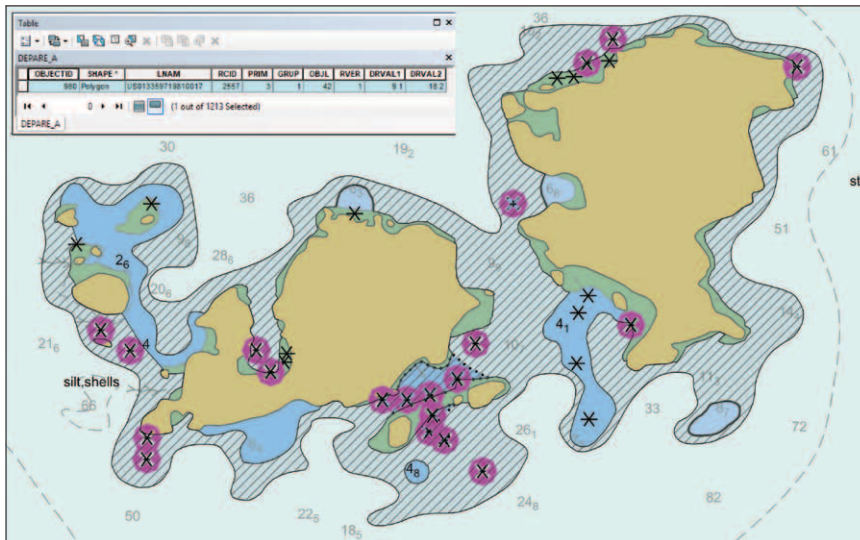

Figure 37-8. Depth area (populated depth range 9.1m – 18.2m) vertically inconsistent with the adjacent land and depth areas.

**Project: Vertical Continuity of Depth Areas and Adjacent Objects**

Spatial objects in ENCs are divided into two groups, namely Group 1 (known as the “skin of the earth”) and Group 2 features. Group 1 features are area-type geo-objects such as DEPARE (depth area), LNDARE (land area), DRGARE (dredged area), UNSARE (unsurveyed area), FLODOC (floating dock), HULKES (hulk), and PONTON (pontoon). For Group 1 features, each area covered by a meta-object M\_COVR (coverage) with CATCOV = 1 (i.e., that continuous coverage of spatial objects is available within this area) must be totally covered by a set of the above geo-objects that must not overlap. As the nautical chart is a projection

of 3D topology onto a 2D surface, the IHO has developed a number of validation checks for ENCs (defined in IHO S-58) to ensure that their topological structure is valid. Many of the checks deal with the vertical component of the nautical chart, ensuring depth continuity is consistent among geo-objects of Group 1, as well as those between Group 1 and Group 2 geo-objects.

However, validation checks for vertical continuity are not exhaustive, and spatial relationships may be violated among adjacent objects. For instance, Figure 37-8 illustrates a depth area which has been encoded with depth range 9.1–18.2 m (shaded area). However, it is apparent that the populated

depth range is incorrect for many parts of the specific depth area (e.g., where the outline of the depth area touches that of land features). Such discontinuities in ENCs may affect research in nautical cartography (e.g., it complicates the surface reconstruction from the charted bathymetric information as for the previous project), undermines the reliability/quality of the product, and, most importantly, may pose a threat to navigation. For instance, for a vessel with safety contour set to 9.1m, ECDIS will treat the water within the entire extent of the shaded depth area in Figure 37-8 as navigable and will not trigger any alarms, although the water depth is less than 9.1m in many parts of the depth area.

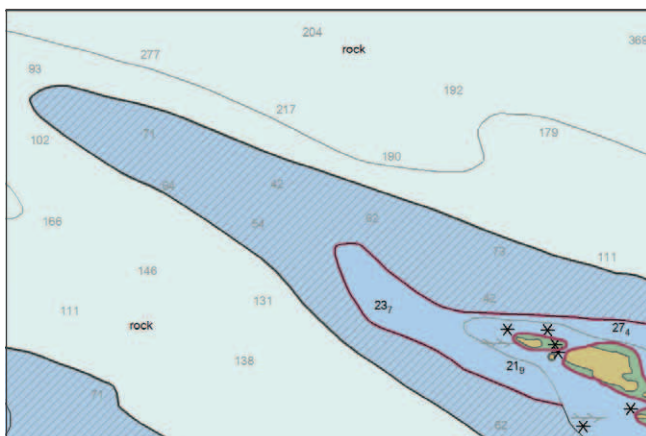

Figure 37-9. Depth area 18.2m–36.5m that appears shoaler than the actual depth in the area.

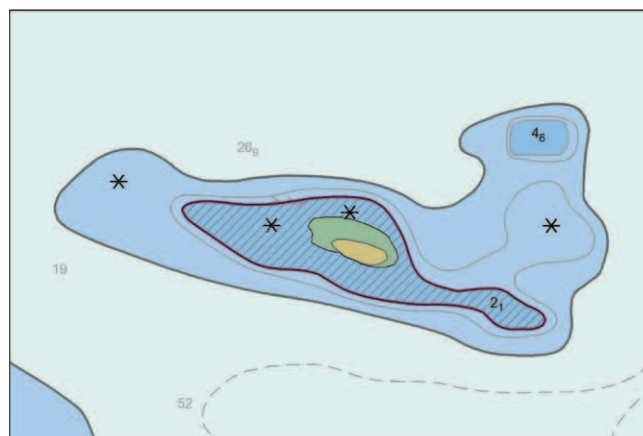

Figure 37-10. Depth area encoded in different units than the Adjoining depth area and the delimited depth curve (i.e., fathoms vs meters).

OID #	Shape #	DEPCNT_LNAM	VALDCO	COALNE_LNAM	DEPARE_LNAM	DEPARE_DRVAL1	DEPARE_DRVAL2	TYPE	Shape_Length	Length_M	
65	Polyline	US099515257512345	0.0		US075746485412345	5.4	9.1	DEPCNT	0.002505	278.897047	
66	Polyline	US070038545812345	0.0		US075746485412345	5.4	9.1	DEPCNT	0.018949	2109.441929	
67	Polyline	US088840287012345	0.0		US075746485412345	5.4	9.1	DEPCNT	0.00321	357.313823	
68	Polyline	US046034898812345	0.0		US091717752710017		9.1	18.2	DEPCNT	0.002247	250.131073
69	Polyline	US011623061512345	0.0		US091717752710017		9.1	18.2	DEPCNT	0.005774	642.800699
70	Polyline	US002275769712345	0.0		US091717752710017		9.1	18.2	DEPCNT	0.000917	102.085352
71	Polyline	US096102988012345	0.0		US091717752710017		9.1	18.2	DEPCNT	0.00214	238.241698
72	Polyline	US074367197312345	0.0		US091717752710017		9.1	18.2	DEPCNT	0.000775	86.253777
73	Polyline	US089417345712345	0.0		US091717752710017		9.1	18.2	DEPCNT	0.001386	154.265792
74	Polyline	US099272617312345	5.4		US091717752710017		9.1	18.2	DEPCNT	0.017995	2003.155879
75	Polyline	US011677662712345	0.0		US091717752710017		9.1	18.2	DEPCNT	0.001166	129.765263
76	Polyline	US067706742512345	0.0		US091717752710017		9.1	18.2	DEPCNT	0.001292	143.813924
77	Polyline	US033099784410017	0.0		US091717752710017		9.1	18.2	DEPCNT	0.001052	117.139623
78	Polyline	US055022088912345	0.0		US091717752710017		9.1	18.2	DEPCNT	0.002366	263.414483
79	Polyline	US035034879012345	0.0		US091717752710017		9.1	18.2	DEPCNT	0.004452	495.638253
80	Polyline	US030149364012345	5.4		US091717752710017		9.1	18.2	DEPCNT	0.003671	408.6177
81	Polyline	US072524841012345	5.4		US091717752710017		9.1	18.2	DEPCNT	0.005622	625.832401
82	Polyline	US099620475712345	5.4		US091717752710017		9.1	18.2	DEPCNT	0.003099	344.949075
83	Polyline	US092102858312345	0.0		US082178747112345		9.1	18.2	DEPCNT	0.000119	13.194436
84	Polyline	US030378490512345	0.0		US082178747112345		9.1	18.2	DEPCNT	0.001589	176.917826
85	Polyline	US082314336112345	5.4		US082178747112345		9.1	18.2	DEPCNT	0.0017	189.188485
86	Polyline	US083993303712345	0.0		US082178747112345		9.1	18.2	DEPCNT	0.003907	434.944299
87	Polyline	US022479393112345	0.0		US073917864610017		9.1	18.2	DEPCNT	0.001557	173.349217
88	Polyline	US086060005112345	5.4		US098888468512345		9.1	18.2	DEPCNT	0.005603	623.703049
89	Polyline	US010517324712345	0.0		US066799155310017		18.2	548.6	DEPCNT	0.003284	365.584103
90	Polyline	US084360025312345	0.0		US066799155310017		18.2	548.6	DEPCNT	0.005425	603.910638
91	Polyline	US013233047712345	0.0		US066799155310017		18.2	548.6	DEPCNT	0.000807	89.790845

Figure 37-11. The output table for US5AK4DM for which the application identified 53 depth areas and 553 coincident edges with errors in depth continuity.

In a different situation of vertical inconsistency, and contrary to that illustrated in Figure 37-8, depth areas may appear shoaler than actually are. Consider Figure 37-9, where the shaded depth area is populated with minimum depth value of 18.2m (depth range 18.2m–91.4m) and adjoins a depth area with depth range 18.2m–36.5m. The coincident depth curve has populated depth value of 36.5m, thus the depth area in question should be split and, where appropriate, be assigned a depth range of 36.5m–91.4m. Cases like this may make navigable waters appear as non-navigable in ECDIS and trigger useless ECDIS alarms, contributing to the unpleasant situation known as “mariner’s deafness.”

Furthermore, other cases of vertical discontinuity on ENC’s are where depth areas have been encoded in units different than the adjoining depth areas, e.g., fathoms instead of meters. For instance, the shaded area in Figure 37-10 has populated depth of “3” (apparently in fathoms) contrary to the proper 5.4 (in meters) whereas the adjoining depth area and their coincident geometry (depth curve) have been properly encoded in meters.

In the previous reporting period, Christos Kastrisios and Brian Calder, in collaboration with Megan Bartlett

(NOAA MCD), worked on developing an algorithm for the automated identification of the vertical discontinuities between depth areas and adjacent geo-objects on charts. The research work aims to improve depth continuity among geo-objects in ENC’s but recognizes that the complete elimination of inconsistencies may be incompatible with the legibility constraint and cartographic design principles. Therefore, the research currently focuses on introducing a semi-automated process, where the algorithm determines the parts of the depth areas that require the user’s attention, with the cartographer being responsible for remediation.

In the current reporting period, the research focused on identifying the geographical situations (and improving the implementation accordingly) where vertical discontinuities are expected (e.g., in the crisp boundaries of shoreline constructions or dredged areas and the adjoining depth areas) so that it captures only the discontinuities of the sea-bottom surface that should not, in principle, occur (e.g., the fuzzy boundaries of two depth areas or a depth area and shorelines).

Furthermore, the team focused on investigating solutions for the identified errors and providing them as

suggestions to the cartographer. The initial approach is recursive and begins with finding corrections for the attribute values. That includes, in the first iteration, the depth areas that adjoin land areas (e.g., the example in Figure 37-8) and, in the second iteration, the depth areas encoded in incorrect units (e.g., the example in Figure 37-10). Figure 37-11 presents the initial situation for the US5AK4DM ENC where the application identified 53 depth areas and 553 coincident geometries (edges) with errors, which, after applying the attribute fixes of the first two steps, are reduced to 41 and 365 respectively (i.e., a reduction of 23% and 33% respectively). Figure 37-12 shows that the populated DRVAL2 depth value of 3 fathoms discussed previously has been corrected to 5.4 meters.

Once the two steps for fixing the attribute errors are complete, the tool iterates between suggesting fixes and altering the geometry of the depth areas. That includes splitting the respective areas and assigning the proper depth range to each new depth area. This functionality is still under development and will continue during the next reporting period. The error fixing process currently results in suggestions for implementation by cartographers. The necessity and feasibility of a fully automated solution, where the determination of inconsistencies and their correction is performed automatically, will be considered in the future.

**Project: Visualization and Integration of Bathymetric Data Quality on ENCs**

Most navigational charts are an amalgamation of geospatial information of varying quality collected using different techniques at different times. Data collected recently with high resolution multibeam echo sounders or lidar systems may co-exist on the chart with data collected with lead-line in the beginning of the 20th century, or as far back as the 18th century. As a means to display the quality of the charted information several cartographic techniques have been developed and implemented. For instance, on paper charts soundings in areas of high certainty are portrayed with an italic face, whereas uncertain soundings are shown in a roman face. Likewise, uncertain depth curves appear broken and/or have greater curvature than those compiled from high quality data. A better approach to these problems remains to be found.

The aim of this research project is the development of new visualization and integration methods of data quality on charts to support decision making on board. The proposed solutions must meet a number of requirements, e.g., visualize the different data quality levels unambiguously, minimally obscure navigational information, be effective to all ECDIS modes, be memorizable, integrate the available quantitative information in the ENC meta-object Quality of

Data (M\_QUAL), minimize calculations and spatial queries, etc. In this reporting period, Christos Kastrisios, Colin Ware, Brian Calder, and Tom Butkiewicz, in collaboration with Lee Alexander and Olivia Hauser, reviewed similar research efforts for the visualization of the Category Zone of Confidence (CATZOC) and the S-100 Quality of Bathymetric Data (QOBD) and examined the suitability of the available visual variables for the purpose. The team also examined the integration of the quantitative aspect of the data quality in the planning and monitoring phases of the voyage.

The efforts of the hydrographic community to portray the quality of data on charts started about a century ago. In 1960, Beaton identified that making the information of data sources available to the mariner would help the mariner to

OBJECTID *	SHAPE *	LNAM	DRVAL1	DRVAL2
359	Polygon	US005968413310017	0	3

OBJECTID *	SHAPE *	LNAM	DRVAL1	DRVAL2
359	Polygon	US005968413310017	0	5.4

Figure 37-12. The attributes table of the depth area in Figure 37-10 before and after the attribute fixes.



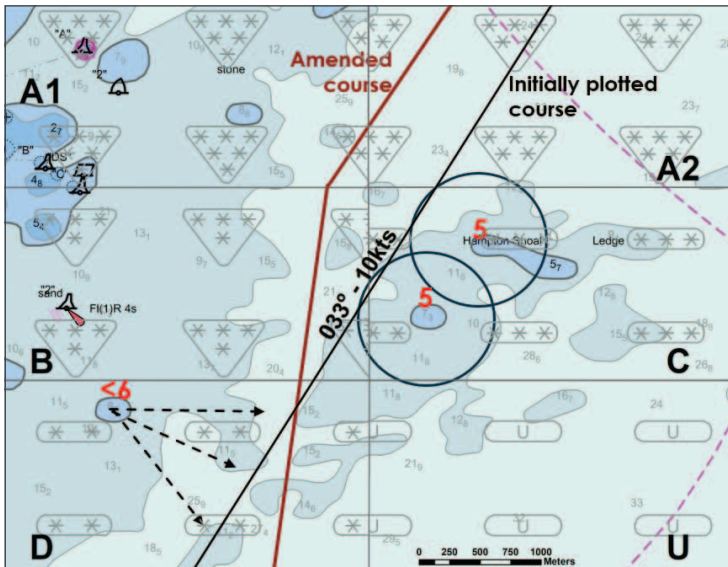

Figure 37-13. The intended course of the ship before and after the appraisal of the shoal features in vicinity.

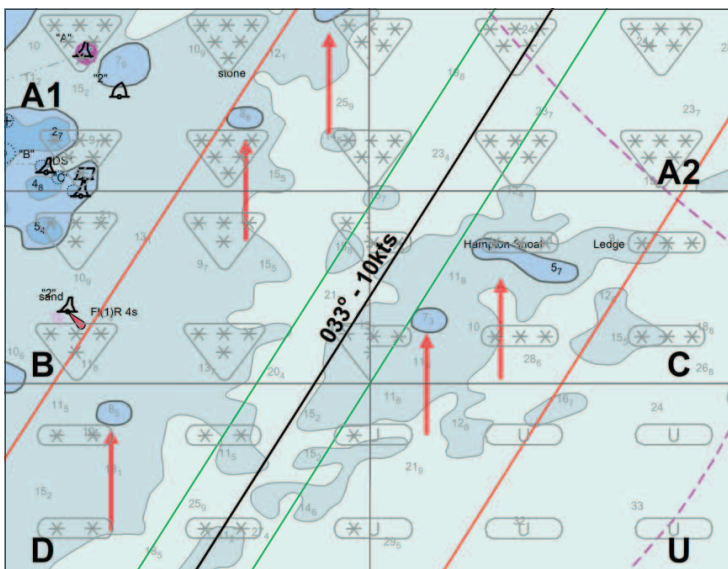

Figure 37-14. Appraisal of shoal features with the support of ECDIS and corridors of different width.

make better, more informed decisions. In this regard, he proposed the implementation of Source and Reliability Diagrams, which were already well established in the land domain. Due to their complexity and construction difficulty, reliability diagrams were not utilized by all HOs and source diagrams became the standard for the portrayal of data quality on charts, including those produced by NOAA. For the source

diagram the geographic area of the nautical chart is delineated in one or more sectors providing a graphic depiction of the source, the year collected, and the scale of the data for each of the sectors. The fundamental principle for interpretation of the source diagram by the mariner was that newer data and data collected by national organizations are better quality data. The simplicity that made source diagrams prevail over reliability diagrams was also why, towards the end of the 20<sup>th</sup> century, they became obsolete. Source diagrams essentially failed to fulfil modern navigation requirements.

The successor of source diagrams, the CATZOC diagram, formed a paradigm shift as the evaluation is performed by the cartographer in-house as part of the compilation process. The significance of CATZOC lies in the fact that each sector in the chart has a quantifiable horizontal and vertical uncertainty associated with it (CATZOCs A1, A2, B, and C), as well as the information about the seabed coverage and feature detection. With this information, mariners may more effectively interpret the seabed morphology, identify shoals that pose a threat for the plotted voyage, and select routes that maintain under-keel clearance. Currently, CATZOC is portrayed as an additional layer with glyphs using a rating system of stars: six to two stars for the best to lowest quality data and "U" for unassessed data. The layer may be activated and de-activated in the ECDIS by mariner.

CATZOC may be used at any stage of passage, but in the planning phase of the voyage, the normal process is for the prudent mariner to plot the planned course and then check for features along the intended course that may pose a threat for the vessel. For each identified bathymetric feature, the mariner accounts for the horizontal and vertical uncertainty and, where necessary, the route is appropriately modified (Figure 37-13). This is a complex task which the mariner can accomplish with the support of ECDIS and a user-defined zone on both sides of the planned course designed to assist in checking for shoals (Figure 37-14).

However, the evaluation within the user-defined zone may result in actual dangers being undetected when a small width value is selected (e.g., the corridor delimited by the green lines) or can trigger useless alarms for shoals that have no immediate effect to the plotted course when a large width is selected (e.g., the corridor delimited by red lines). Furthermore, research has shown that the current representation of bathymetric uncertainty is difficult to understand for mariners and, thus, is rarely used. A better method of providing the information to the user is therefore required.

A common theme of recent research into the portrayal of uncertainty is the utilization of established visual variables (e.g., hue and textures) to better visualize data quality on charts, but they seem to have specific drawbacks that make a new, comprehensive analysis necessary. In this research effort we are examining the visual variables for their suitability for the application. Color is one of the strongest visual variables, but the preliminary results of this work show that the three dimensions of color (i.e., hue, lightness, and saturation) seem ineffective for several reasons. Particularly, most primary and secondary hues are already reserved for other uses in the ENC/ECDIS or are not suitable for all ECDIS modes, lightness and saturation interact considerably with base information and may alter the perception of the underlying features on the chart by the user (e.g., depth areas in dark blue for shallow waters may appear light blue and may be interpreted as depth area of deeper waters, and vice versa), the portrayed layer obscures considerably the base information of the ENC, and the portrayed layer of data quality becomes dominant in dusk and night modes. The visual variable of size does not have the issues attendant on color, but the identification of the different CATZOC levels becomes ambiguous especially when only one or two of the six levels are portrayed on the screen. The preliminary results point to similar conclusions for the visual variables of shape, orientation, and variation in grain (density), as they, to greater or lesser degree, create an ambiguous visualization of the ZOC/QOBD levels, especially in the stressful situations that the mariner may experience on the bridge when time is of the essence.

The solution that seems most promising is to use a sequence of textures to represent the CATZOC level of uncertainty, Figure 37-15. Each texture must be visually denser than the last, with denser textures representing greater uncertainty, and each texture must be designed to be clearly distinct from the

previous one so that their values can be unambiguously perceived. The advantages of textures is that they are minimally used in current ECDIS displays, and if they consist of open meshes they will minimally interfere with other chart information (unlike color). The research team will also consider factors such as the viewing distance, minimum sizes for legibility, minimum separation of features, size of fonts and symbols in ENC, and so on. The idea will be further developed with alternative (simpler if possible) designs (e.g., textures created with squares as the main shape) and an evaluation study with the participation of professional mariners will be carried out to compare them.

One more aspect of our research project is the determination of the area to be visualized and utilized for the identification of potential dangers for the plotted course. Prior solutions use a layer (color or texture) that covers either the entire extent of the chart or a user-defined/fixed width zone around the plotted course (Figure 37-16). As an alternative we investigate the use of zone of width equal to the horizontal uncertainty in the area (Figure 37-17). The advantage of this lies in the fact that shoals charted with high certainty (e.g., ZOC A1) not in the vicinity of the plotted course (which therefore do not pose a threat) will not be treated as a threat (but those with higher horizontal uncertainty would), contrary to an implementation that covers the entire area or uses an arbitrary value as zone width (Figure 37-16). This approach, from an analytical perspective, is expected to have the same results as with generating circles with radius equal

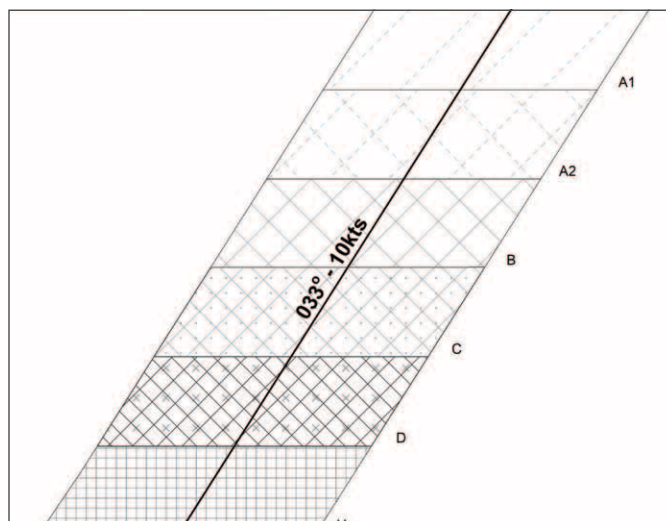

Figure 37-15. A visualization of the six levels of data quality with textures as a combination of orientation, density, and shapes.

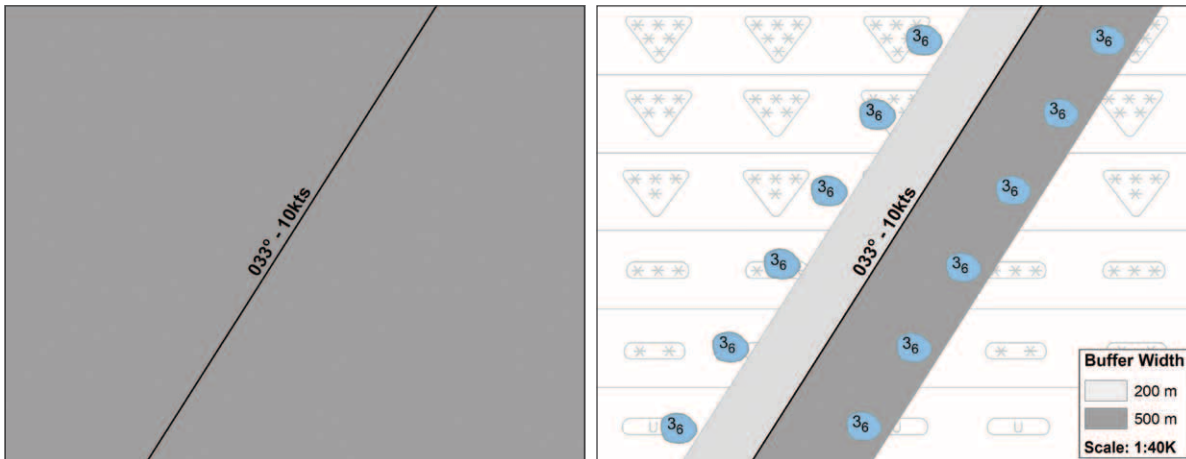

Figure 37-16. Existing works on the visualization of data quality use the entire extent of the chart (left) or an arbitrary zone on both sides of the plotted course (right).

to the horizontal uncertainty around every shoal, but requires fewer computations and spatial queries. From a cartographic communication standpoint, it adds significantly less clutter to the ECDIS screen than a series of circles around every potential shoal in the screen.

Selection of the width of the zone for visualization is a key aspect of the research. Figure 37-18 shows a preliminary decision tree for the determination of the width value that incorporates the meta-object M\_QUAL, where IBW corresponds to the initial buffer width, set equal to the horizontal uncertainty value of the underlying M\_QUAL for the segment of the plotted course under investigation, and BW is the final buffer (zone) width that will be used for the visualization. The final decision for the features that will be flagged

within the zone will likely also include additional information about their accuracy encoded in the ENC (e.g., meta-object M\_SREL). The size of the width at chart scale, which especially for ZOCs A1 and A2 will be very small when a large area is displayed on ECDIS, is an important consideration. Other options (e.g., zone width as a factor of the display scale, or ship characteristics) are possible, and will be considered along with practice in the maritime profession.

**Project: Towards Automated Compilation of ENCs**

Current methods for generation of ENC products are strongly human interactive. While many database-methods are now used, and there are good support tools, current methods necessitate the maintenance and storage of digital product objects as first class entities (i.e., objects which have to be maintained for a significant length of time independent of their initial source data). This implies a significant effort in distribution, update, maintenance, and consistency checking, which can heavily impact efficient generation of products. The idea situation would be to have charting products generated at the right scale for the user’s current situation, at the point of use, and then be discarded immediately afterwards. Of course, navigational safety and cartographic principles imply large constraints on how this would have to work, and may limit the extent to which such an idea could be implemented. The research team therefore aims to understand, define, document, parametrize, and simulate the compilation process as a prelude to more automated solutions. Essential to this is a comprehensive model of the inputs, the generalization operations, the cartographic rules,

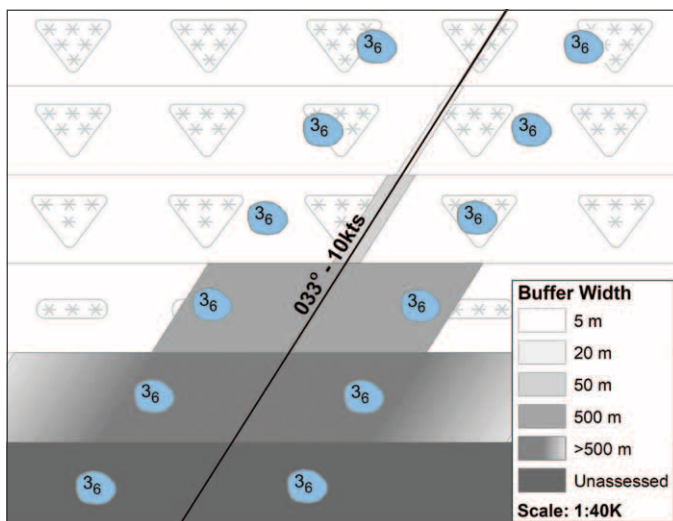

Figure 37-17. A visualization with zone width equal to the horizontal uncertainty in the area.



and the interim products. Tamer Nada, under the supervision of Brian Calder and Christos Kastrisios, is leading the modelling effort, starting with reviewing and incorporating into the model the established cartographic derived from international and national standards. The effort continues.

## Project: Nautical Chart Generalization

A key component in automating chart compilation is the ability to generalize to scale from source data. Kastrisios has therefore been collaborating with colleagues at the National Technical University of Athens on understanding generalization, and in particular generalization of the shoreline, depths, and depth contours.

The development of the generalization rules and methods take into account:

- The IHO specifications for nautical charts and ENC<sub>s</sub>,
- The NOAA specifications for nautical charts and ENC<sub>s</sub>,
- NOAA's basic scales for charts, of 1:10,000; 1:20,000; 1:40,000; and 1:80,000.

A critical decision for the generalization of the features considered is the approach to be followed for their portrayal at each of the basic chart scales. The analysis of the chart specifications led to a "ladder approach", meaning that each scale will be the result of generalization of the features of its larger scale equivalent. This implies that the creation of the content of the chart at 1:10,000 scale through generalization is of paramount importance for all subsequent smaller scales. In this framework,

depth contours and soundings need to be gradually generalized across the scales to ensure intra-layer (horizontal) and intra-scale (vertical) consistency. The need to portray a subset of the original soundings from the NOAA DTM across scales on charts limits DTM generalization as a solution, although alternative approaches focusing on DTM generalization are possible, and will be tested in the next reporting period.

The approach being pursued is very flexible. Although this is not required by the specifications, it is believed that a parametric approach will contribute considerably to the process, thus fulfilling the specific NOAA requirements. For example, when considering density of depths to be portrayed, the algorithm allows the user to explicitly set the density of depths required, and to set the distance parameters in the generalization operators used for aggregation, simplification, smoothing, etc. The effort towards the development of a set of rules for the generalization of basic features portrayed on any nautical chart or ENC showed that there are a number of alternative approaches to tackle this problem. Such approaches have been proposed in the literature but they are not support at all by clear and cohesive rules for their implementation. Given that the rules under development in the framework will be used to assist in automated generalization, the preferred solution is for a system that avoids lengthy analyses of the morphology of the sea bottom, which may lead to questionable results.

Although the approach under development appears to be viable for production use, there are many alternative methods still to be investigated. The effort continues.

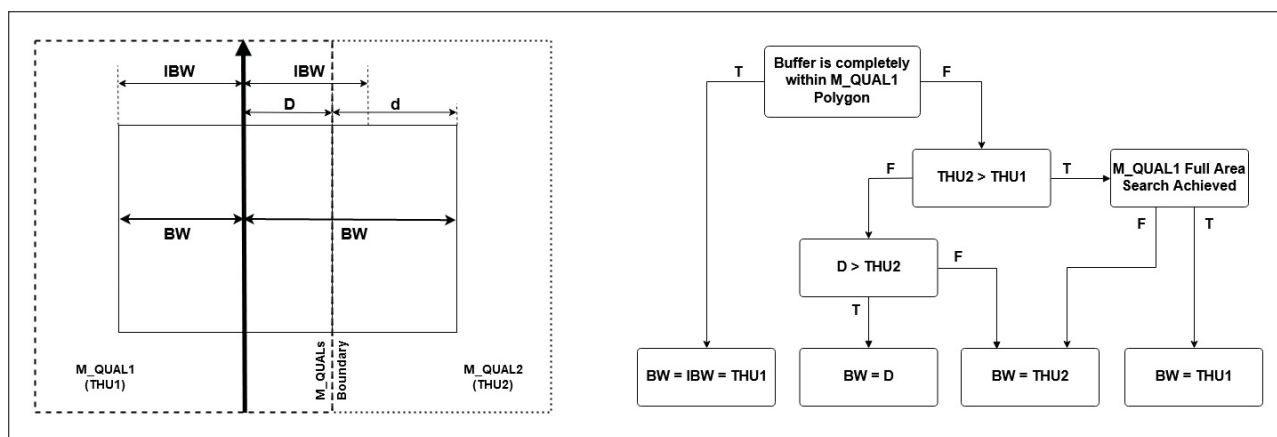

Figure 37-18. Preliminary decision tree for the width of the zone on both sides of the plotted course.

**TASK 38: Chart Adequacy and Re-survey Priorities:** Investigate methods to formally assess the adequacy of a chart based on many factors, weighting the strength of each so as to determine a metric that can be normalized over many charts or chart areas, so that it can be used to rank areas in order of resurvey need. In addition, there is a requirement to determine the value of a survey in any given area, defined as the benefit to the adequacy of the chart that is derived from conducting a survey (i.e., if we resurvey an area, how much better does the chart become?) and we, therefore, propose to investigate methods to assess survey benefit as an economic driver in the resurvey priority decision. Linked together, these two methods may provide a schema to rationalize the setting of resurvey priorities beyond the “Critical Area.” These efforts are clearly linked to our seafloor change analyses and risk model efforts (Task 30 and Task 41). PIs: **Brian Calder, Christos Kastrisios, and Giuseppe Masetti**

Assessing the adequacy (suitably defined) of current charts, for decisions on either chart replacement or resurvey priority, has become a common theme for many hydrographic agencies faced with large chart portfolios and limited resources. One approach to this problem is to focus on the data represented by the chart, rather than the chart itself, and assess the risk experienced by surface traffic in any given area. In doing so, special attention must be paid to the assumptions inherent in that data (e.g., of survey completeness and object detection) which might not be explicitly provided on the chart. In a previous reporting period, Brian Calder developed a risk model that could be applied in a variety of circumstances to provide assessments for general shipping traffic, addressing specifically bathymetric information and the potential for incomplete surveys to affect the risk estimated. In the 2016 reporting period, Calder adapted this model to assess resurvey priority, and applied it to an area in the Chesapeake Bay. The results of the analysis agreed with intuition on data quality, completeness, and risk, but also suggested some counter-intuitive notions on what type of resurvey might be appropriate in the area.

*No further effort was committed to this task during the current reporting period.*

**TASK 39: Hydrographic Data Manipulation Interfaces:** Investigate interfaces, interaction methods, and visualization techniques for the inspection, analysis, and remediation of hydrographic data problems, with particular emphasis on novel interaction methods and computer-assisted depiction of problem areas. Specifically investigate visualization techniques for point-wise hydrographic data, and variable-resolution gridded data, with particular emphasis on clear depiction of the data within hydrographic constraints as well as gesture-based interaction, stereo imaging, and multi-touch capable displays. PIs: **Brian Calder, John Hughes Clarke, Tom Butkiewicz, and Colin Ware**

#### **Project: Immersive 3D Data Cleaning**

**JHC Participants:** Tom Butkiewicz, Andrew Stevens, and Colin Ware

No matter how comprehensive, and effective, automated processing tools become, there is always likely to be some data that needs to be examined, and manipulated, by a human operator, by hand. The efficiency of interaction with the data is, therefore, an essential component of the overall efficiency of the data processing pipeline since the human interaction cannot otherwise be accelerated with faster machines. As part of the ongoing effort to explore new interfaces for hydrographic data manipulation, Thomas Butkiewicz and graduate student Andrew Stevens created, and continue to develop, an immersive 3D, wide area-tracked, sonar data cleaning tool.

Previously, Butkiewicz and Stevens conducted an experiment to compare cleaning performance between the Center’s novel VR interface and a generic desk-

top monitor and mouse/keyboard based interface representative of traditional software packages. The study showed a clear advantage when using the VR interface with regard to completion time, while errors were generally equivalent between the interfaces.

However, because users can be reluctant to use immersive interfaces and wear head mounted displays for long periods of time, we have also developed a desktop monitor based, non-immersive version of our editing software (Figure 39-1). While users do not get the same depth perception and head coupling benefits, the handheld six degree-of-freedom controllers are still a better interface than a mouse for the inherently 3D task, which preserves much of the benefits our immersive system presents over traditional interfaces.

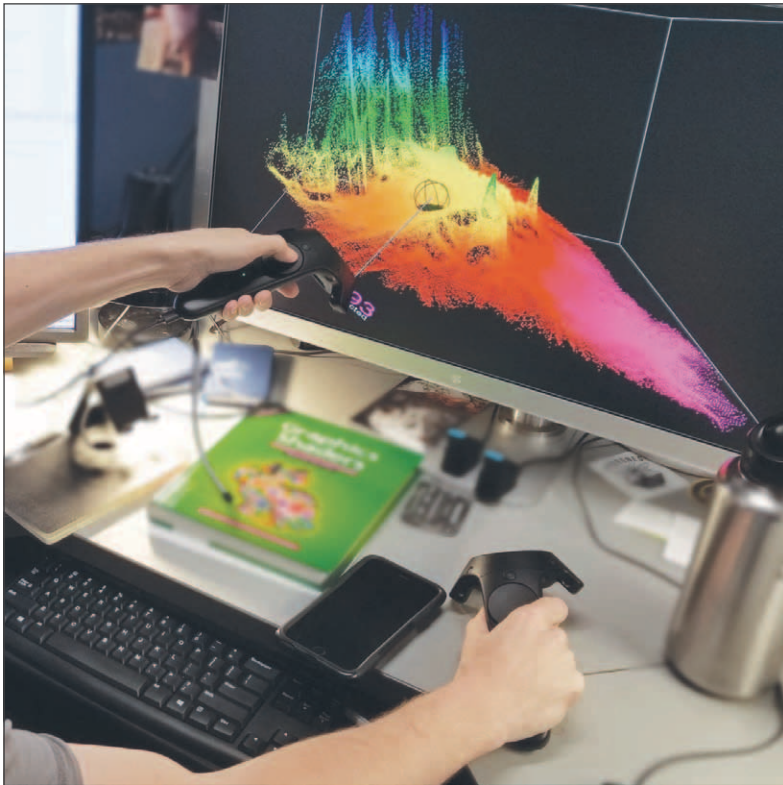

Figure 39-1. Our point cloud editor being used on a standard 2D desktop monitor, where the 6DOF handheld controllers can be used to “reach into the screen” and edit, manipulate, reposition, and scale data similar to the immersive mode.

A follow-up study was conducted to evaluate this hybrid desktop-monitor configuration, in order to isolate and understand the individual benefits of the six-degree-of-freedom handheld controllers in the



Figure 39-2. Editing coastal LIDAR point clouds with the latest version of our desktop editor, which uses a 3D monitor and 6DOF handheld controllers.

absence of the head-coupled 3D display. We found error rates to be roughly the same as the immersive and traditional desktop modes, and completion times were similar to VR, except that the most challenging datasets (those with embedded noise) did take significantly longer, which appears to be a result of the interaction volume being constrained by the desk and monitor and the smaller display. This configuration forced users to perform significantly more manipulation actions to reposition the data set within the restricted viewing and interaction volume. However, it still performed better than traditional, mouse-based desktop editors.

A detailed description of this project and the results of our experiments can be found in the paper: “Faster Multibeam Sonar Data Cleaning: Evaluation of Editing 3D Point Clouds Using Immersive VR,” which was published in *IEEE/MTS OCEANS’19* in October 2019.

Most recently, we have added support for lidar point clouds (Figure 39-2), as this tool may actually find more application cleaning lidar data than sonar data. We have also been developing a new hybrid controller than can be rested on the surface of the desk and used as a traditional mouse, but when raised off the desk surface, it automatically switches to acting as a 6DOF 3D controller. This should allow users to quickly use the device to perform 3D operations as needed, while not decoupling them from their existing workflow, i.e., they would still be able to interact with the traditional 2D interfaces of their existing desktop software editing packages, and multi-task across other applications.

While we strongly believe in the power of our immersive interface, we recognize that



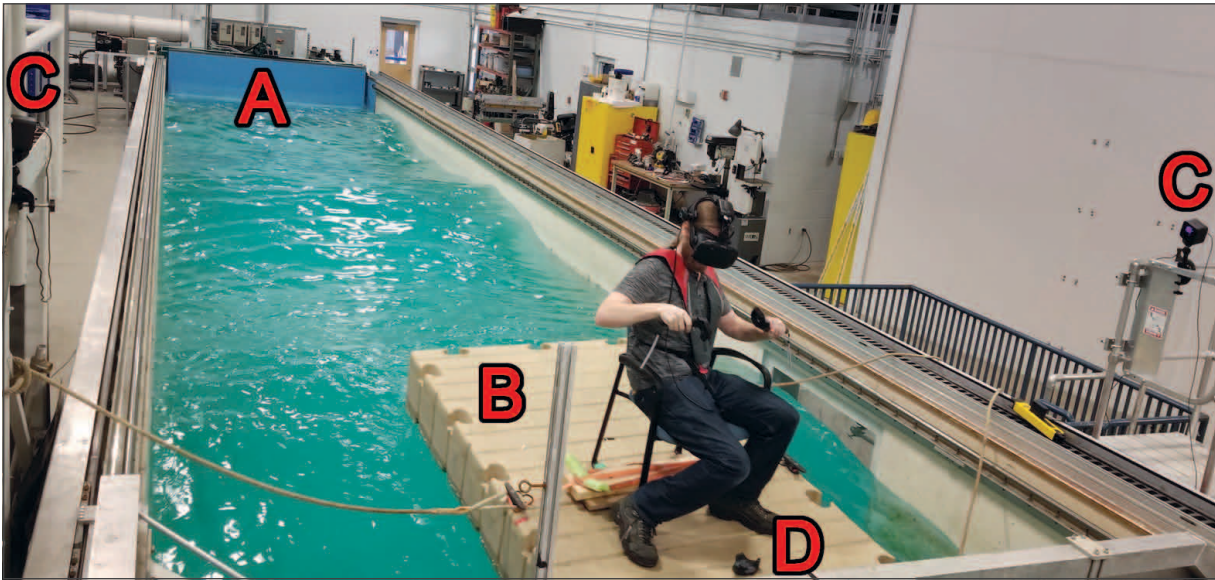

Figure 39-3. Our nauseagenic testing setup. The paddle (A) at the end of the tank creates waves which induce motion on the floating platform (B). The tracking cubes (C) on the sides of the tank provide a fixed reference space, while a tracking device (D) provides the platform's pose, which is used to compensate the visuals in the virtual environment to match the felt motion, reducing motion sickness.

there are significant barriers to adoption, and hope that our hybrid desktop editor and mouse-emulating 6DOF controller will persuade data cleaning software manufacturers to include such interface options in their editing software.

Finally, an issue with our immersive interface is that sonar data is often cleaned aboard moving vessels, which can create motion sickness. Users of VR can experience motion sickness as well, in the form of "simulator sickness." Combining the two presents a worst-case scenario for motion sickness. Advice for avoiding seasickness often includes focusing on the horizon or objects in the distance, to keep your frame of reference external. We experimented with

adding a virtual horizon and moving the surroundings in our virtual environment to match vessel motion, to assess whether it provides similar visual cues that could prevent motion sickness. An informal evaluation in a seasickness-inducing simulator was conducted (Figure 39-3), and subjective preliminary results hint at such compensation's potential for reducing motion sickness, enabling the use of immersive VR technologies aboard underway ships.

Details on our motion compensation experiment can be found in the paper, "Reducing Seasickness in Onboard Marine VR Use through Visual Compensation of Vessel Motion," which was published in March 2019 in *IEEE Virtual Reality*.

### Project: Constrained 2D/3D Data Manipulation Interfaces

**Participants:** Brian Calder, Giuseppe Masetti, and Colin Ware

As an alternative to an immersive 3D interface, Ware, Brian Calder, and Giuseppe Masetti have continued efforts to develop a "conventional," but more efficient user interface for handling data from the CUBE and CHRT algorithms. That is, assuming you start with a conventional data processing system, what could be changed in the interactions to improve the usability, speed, and accuracy? A particular difficulty recognized by all users of current data processing interfaces is that they are poorly adapted to the data,

and demand a great deal from the operator, which makes their use slow and problematic. Specific examples include a continuously variable scale with ill-designed sub-sampling schemes, which can obscure significant cues to data problems, and the use of a pseudo-3D interface with 2D interaction tools.

Most existing interfaces for sounding data approach the problem as a simple 3D display of points, or color-coded, sun-illuminated bathymetry. The user

can freely zoom the display and rotate the points to identify which soundings are causing problems for the underlying algorithm that is estimating depth, after which a simple (2D) lasso tool is used to select points for removal. Unfortunately, however, once the interface stops moving, the illusion of 3D perspective mostly disappears, and 2D lasso tools make it difficult to select just the points required (i.e., it is relatively easy to select “background” points). Consequently, many operators spend a great deal more time maneuvering the data into the right positions in which to conduct edits than they do actually editing.

The basic idea for the BathyEditor prototype is to provide scientifically rigorous perceptual and cognitively optimized visualizations and interaction methods for the data. For example, rather than providing a very flexible display that is perhaps more suited to final product visualization, we limit the user’s ability to adjust the scale of the display, such that they are able to better focus on their actual task. The design strategy for the new tool is therefore to provide an interface that allows operators to rapidly home in on areas where there may be problems with the data; once such a region has been identified and selected, a complete array of all the necessary data editing task-relevant views are immediately provided with easy-to-use controls for data editing. A proof-of-concept application has been developed incorporating the following principles:

#### Main View and Information Scent

The main overview display panel provides the best possible information scent leading to areas that should be checked and possibly edited by the operator. “Information scent” is a term from the user interface design literature referring to visual cues provided in high-level displays that can reliably lead to useful information obtainable via drill-down operations. Currently this view shows color coded bathymetry. A colormap has been designed to ensure that a designated deviation in the bathymetric surface (possibly representing a flier) is visible. This also requires that the bathymetric surface be displayed at an appropriate scale. Since a fixed colormap may not be adequate to accomplish this goal in cases where there is a large depth range, it is adjusted to give an appropriate color range for each selected region.

#### Linked Views

When a region that may require editing is identified, selecting it results in all related information appearing immediately in linked views. This provides a cognitive benefit by greatly reducing working memory load when information from different views must be mentally integrated. When an area is selected for detailed examination, five other views of this region are created. These are shown in the right-hand side of Figure 39-4. From top to bottom on the near right they are 1) a view showing the number of CHRT hypotheses, 2) a wire mesh view, 3) a point view of the soundings color-coded by track line, and 4) a shaded view of the CHRT surface. Kinetic depth has been shown to be the most powerful cue for 3D perception of point clouds and is more important than stereoscopic depth. Thus, to support 3D perception of the data, the 3D views in the near right of the display oscillate continuously about a vertical axis.

The fifth view, on the far right, is the editing view. As a cognitive optimization, editing windows present information in such a way that possible fliers can be eliminated with a single click in most cases. In most cases, a simple parabolic selection tool can be positioned using the mouse for this purpose. For cases where there is a considerable slope, the view can be rotated by the operator using his or her non-dominant hand on the keyboard, while their dominant hand is used to control a parabolic selection tool with the mouse.

#### Tight Coupling with CHRT

CHRT does the work of finding which areas must be examined by the operator. CHRT also computes the surface. Other back-end algorithms could also be used.

#### Artificial Flyers to Increase Vigilance

Systematic data coverage is ensured by using artificial targets (e.g., flyers) inserted into the data. These types of false positives are intentionally added to displays in order to ensure that operators have something to identify and to provide a metric for verifying that areas have been thoroughly inspected.

#### Minimize System Latencies

It is well known that system lag can result in a disproportionate loss in cognitive throughput. Two of

the main system latencies in existing data cleaning systems are the time taken to bring up 3D views and the time taken to re-CHRT the data. Substantial effort has gone into reducing latencies. In the current reporting period, additional work has been done on both CHRT and the interface, to support the development of this new tool. The prototype now loads the following from CHRT:

- Individual soundings in a designated area. These are attributed by line (file), ping, and beam.
- The estimated depth surface.
- The number of hypotheses at each point on the grid.

BathyEditor's proposed interface is a significant departure from the accepted norm of hydrographic data processing methods, and will, therefore, require careful calibration and validation through user interaction studies. A user study is therefore under

development. This will evaluate the prototype editor by comparing it with Teledyne CARIS HIPS 10.4 for processing times and accuracy. In both cases, we will compare the cleaned surfaces against a standard surface that has been cleaned by at least two experts.

The data set to be used in the evaluation is from a survey carried out by the NOAA Ship *Whiting* in the vicinity of Woods Hole, Massachusetts (the same dataset was used as part of the original acceptance testing for the CUBE algorithm). Two equally-sized regions (designated A and B) have been identified for cleaning. Together these represent approximately half of the survey area. A within-subjects design will be used, meaning that all participants will use both interfaces, either processing area A with the BathyEditor and area B with HIPS, or the reverse. Half the subjects will process with HIPS first and half with BathyEditor first.

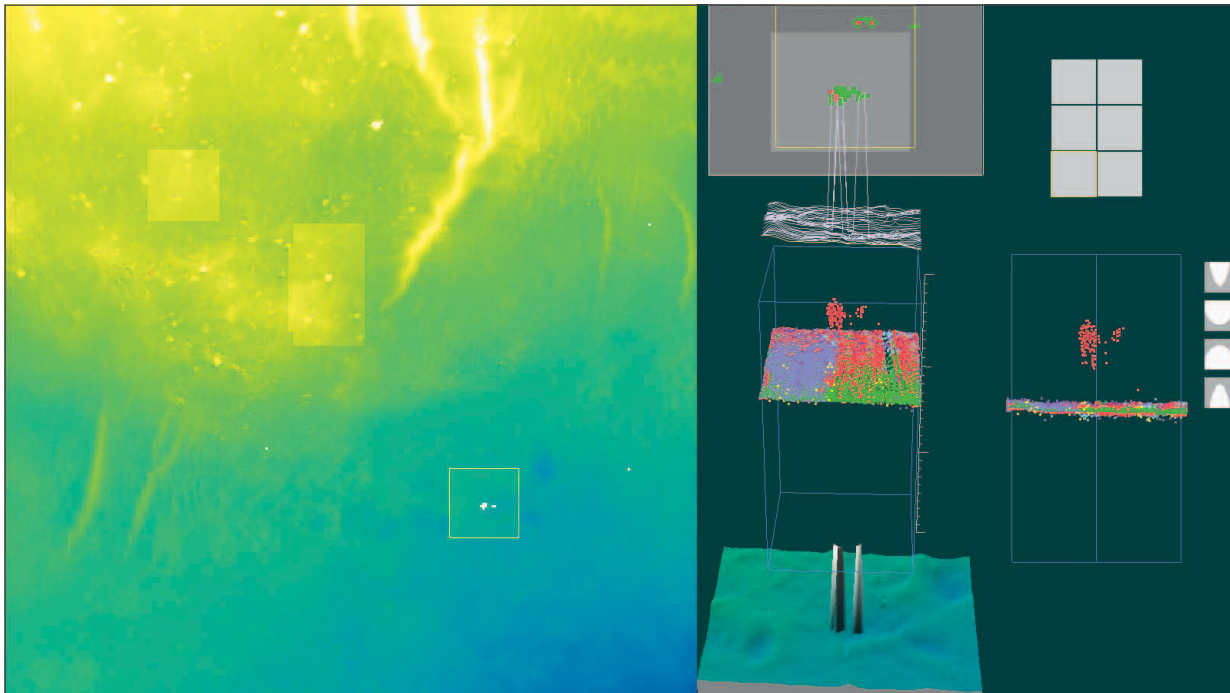

Figure 39-4. The interface to BathyEditor, an experimental prototype data cleaning system.



## Research Requirement 2.B: Comprehensive Charts and Decision Aids

**FFO Requirement 2.B:** “Development of innovative approaches and concepts for electronic navigation charts and for other tools and techniques supporting marine navigation situational awareness, such as prototypes that are real-time and predictive, are comprehensive of all navigation information (e.g., charts, bathymetry, models, currents, wind, vessel traffic, etc.), and support the decision process (e.g., under-keel clearance management).”

### THEME: 2.B.1: Information Supporting Situational Awareness

**TASK 40: Currents, Waves and Weather:** *Improve navigation planning systems by the development of methods showing forecast ocean currents, sea state, and surface winds, and specifically to demonstrate methods for high quality portrayal of ocean and near-shore currents, sea state and weather information on electronic chart displays; investigate animated portrayals of the same variables; and investigate the use of multi-slice profile views to show current speed, salinity and temperature distributions. We propose to design, build, and evaluate prototype displays based on sound perceptual principles. We will work with NOAA and appropriate IHO committees (e.g., Tides, Water-levels and Currents Working Group – TWCWG) to evaluate these products and help establish standards for the portrayal of this information. Pls: **Colin Ware, Briana Sullivan, and Vis Lab***

#### Project: TWCWG/Surface Currents – S-111

JHC Participants: Colin Ware, Roland Arsenault, and Briana Sullivan

The future of electronic charting cannot leave behind the supplementary data that aids the mariner in the decision-making process. The elements that surround the mariner in the marine environment all contribute to the story of what kind of journey will unfold. Understanding their contribution in both planning and while underway is important to safety and efficiency. Two specific components are the surface currents and weather. S-111 is the IHO standard for surface currents, S-412 is the IHO standard for weather overlays on electronic nautical charts, and S-126 is an IHO

standard that includes Nautical Textual Information (NTI) about the physical environment including surface current and weather information.

Briana Sullivan’s prior work with the IHO’s Tides, Water-levels, and Currents Working Group (TWCWG) has resulted in the release of version one of the S-111 *Surface Currents Product Specification* that contains an arrow design and color scheme developed by the Center and tested by the Vislab. This RTO project has been in development since the inception of the

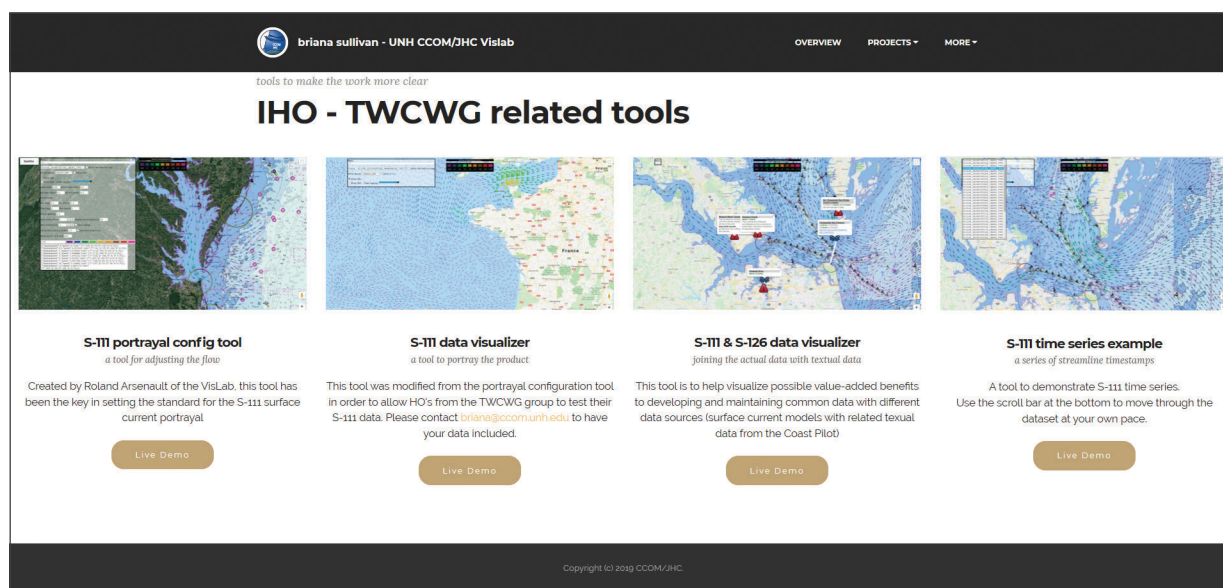

Figure 40-1. Landing page for TWCWG related tools. Tool 1 left, Tool 2 middle-left, Tool 3 middle-right, Tool 4 right.

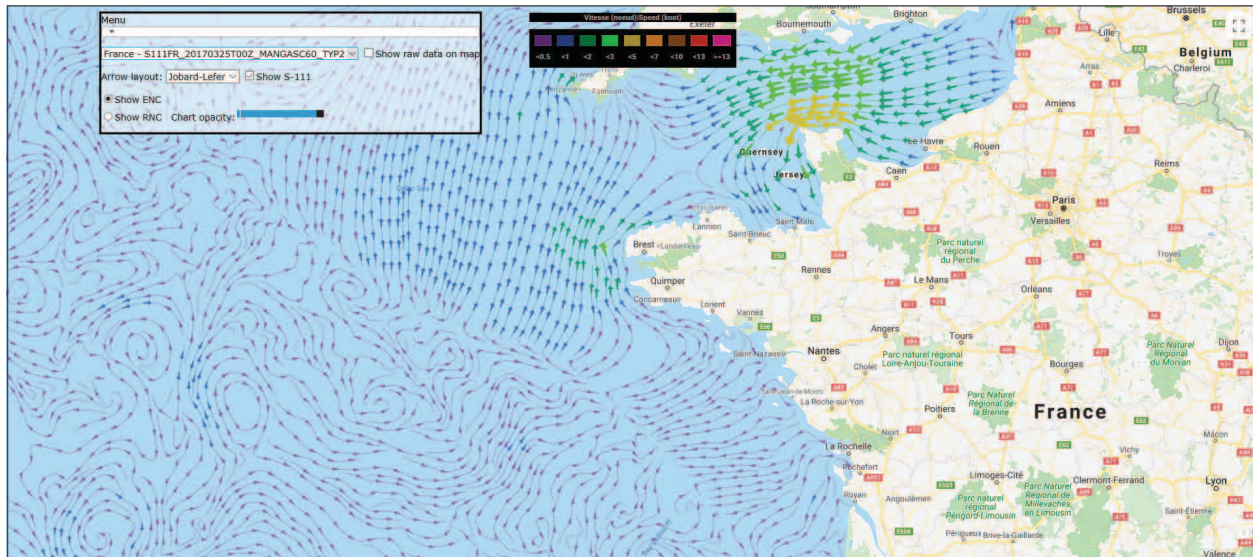

Figure 40-2. France's submitted data set hosted at <http://vislab-ccom.unh.edu/~briana/s100/twcwg-s111-test-data.html>.

SCWG (Surface Current Working Group), a TWCWG sub-group, in 2014. This year the TWCWG requested that the next version of S-111 contain a standard for displaying the data as streamlines as well; something Colin Ware, Roland Arsenault and Sullivan created to improve upon the gridded arrows. Arsenault has updated the code in C++ and it was sent to WR Systems to convert into the S-100 standard LUA scripting language, which will then be submitted as a portrayal standard within the S-111 product specification.

The release of the S-111 Surface Current Product Specification has allowed more Hydrographic Offices (HOs) around the world to begin building their own products. However, currently there are no tools to visually check the output of the data HOs are producing since the standard is so new and manufacturers are waiting for the portrayal section of the standard to become stable. To assist with this issue and give access to other surface current related tools, Sullivan created the following suite of tools for the TWCWG group to enable them to visualize and verify S-111 products:

**Tool 1: S-111 Portrayal configuration tool** (Figure 40-1 left): a surface current visualization refinement tool (it allows for adjustment of the various parameters on-the-fly to demonstrate how the shape, distance and color of the arrows and streamlines were developed)

**Tool 2: S-111 Data visualizer** (Figure 40-1 middle-left): surface current visualization tool for HO's with data. We are now hosting data generated by the US, Canada, Japan, Germany and France to help verify the correctness of their data. (see Figure 40-2 for France's data).

**Tool 3: S-111 & S-126 Data visualizer** (Figure 40-1 right): A tool for the S-100 world to see what multiple data products could look like together. This demonstrates the S-111 surface currents viewed in conjunction with the S-126 surface current related data to show how the supplemental information to the chart is beneficial and adds value to the decision-making process. It allows for a demonstration of how supplemental text could be filtered out for specific tasks, reduced to simplify the burden of the mariner, and overlaid with context to augment what is on the screen without added clutter. Sullivan has been studying the elements of the Coast Pilot related to S-126 (such as surface currents) and creating ways to isolate the physical environment elements from the rest of the text (the visualization of such information is detailed in Task 43).

**Tool 4: S-111 Time Series example** (Figure 40-1 right): A tool to demonstrate the S-111 time series.

Figure 40-1 is the webpage Sullivan created as a landing page for all the tools now available to the TWCWG group as well as the public: <http://vislab-ccom.unh.edu/~briana/twcwgTools.html>.

In addition, last year Sullivan spent time investigating the components of the S-412 data model comparing it with Coast Pilot related information in the hopes to determine how the textual data might support the modeled data. This was put on hold while changes in NOAA personnel working with the S-412 data settled but will continue to be investigated in the coming year.

**TASK 41: Under-Keel Clearance, Real-time and Predictive Decision Aids:** *Develop methods to assess the input parameterization for real-time under-keel own-ship models, and then to apply these models to form real-time interactive decision-support tools, with off-line planning modes, allowing the user to choose the most appropriate method for the task in hand. Specifically, investigate and develop methods for the assessment of geological and anthropogenic variability in a survey area, with the aim of providing calibration constants for risk-based under-keel clearance models. Investigate methods for establishing the own-ship calibration constants as well as methods for adapting real-time and predictive environmental models for use in the appropriate segments of the risk-based under-keel clearance model. In visualizing the results of this model, we will investigate methods for portraying the uncertainties and risk associated with this information in a fashion most meaningful to the mariner.*

**PIs:** *Brian Calder and Vis Lab*

**JHC Participants:** Tom Butkiewicz, Christos Kastrisios, and Briana Sullivan

In past (and indeed present) hydrographic practice, the ability of the hydrographer to express to the end user the degree of uncertainty, writ large, of the data being presented for navigational purposes has been extremely limited. Methods such as source or reliability diagrams on two dimensional products, or CAT-ZOC objects in electronic navigational charts, have attempted to convey somewhat of the uncertainty. These methods, however, mostly represent what was done during the survey effort that provided the data, rather than what the mariner may safely infer from the chart about the potential for difficulties in sailing through any given area.

One approach to this problem is to focus on the risk engendered to surface traffic of transiting through a given area, taking into account such issues as ship parameters, environmental conditions (e.g., wind and wave effects), and especially the completeness and uncertainty of the bathymetric data available. Given a sufficiently general model, it would be possible to assess the potential risk for a specific ship following a planned course (e.g., during passage planning), moving through (or anchoring) in an area (e.g., to assess a generic "risk map" to be provided as a static or dynamic overlay on a charting interface), or to provide predictive guidance for the mariner in real time of the risk associated with changing the ship's direction in reaction to developing conditions. In the simplest case, the risk could be assessed as the potential to ground the ship, but more complex scenarios with costs associated (e.g., taking into account the potential cost of clean-up, or of damage to a protected environment) could also be considered.

Moving towards this goal, in the current reporting period, a new project has begun that focuses on researching new ways to make use of modern high-resolution data products, including bathymetry (e.g., S-102) and tides, currents, and flow models (e.g., Operational Forecast Systems). Still in the early development stages, it focuses on how to use these data

products to support precision navigation in the voyage planning stage. This includes presenting the mariner with tide-aware underkeel clearance information in go/no-go areas, timing passages under bridges to match low-tides, and avoiding dangerous cross-currents.

To support this, Tom Butkiewicz has begun working with industrial partner SevenCs to use their Nautilus SDK along with their ORCA MASTER G2 ECDIS and ORCA PILOT X PPU software packages to experiment with new precision navigation visualizations. This is a great opportunity to develop and deploy our visualization techniques within a commercial ECDIS/PPU platform, which supports easier adoption of techniques we develop.

We are also investigating how to integrate the ORCA ECDIS/PPU platform within our existing virtual reality ship simulator, allowing for the ECDIS/PPU to be both viewed and interacted with entirely from within the simulation, just as it would be on a real ship's bridge. This should enable us to conduct user evaluations in a range of simulated scenarios. We are planning a simulation of the lower Mississippi around the Port of New Orleans, pending data delivery from NOAA. Scenarios would include passage under a bridge with tight overhead clearance, navigation of a sharp corner with strong currents, and docking a large vessel (e.g., a cruise ship).

Whereas current ECDIS software will display current information at a particular timestep, Butkiewicz is developing a new space-filling image processing algorithm designed to dynamically predict the times at which the ship could be in each location, and to interpolate current/tide information at every location based on these times. By viewing the currents as they are predicted to change along a voyage, the mariner will be able to interactively adjust their planned speed between waypoints, and immediately see the results, which should be helpful for avoiding dangerous situations and taking advantage of helpful currents. Further development is expected in the following reporting period.



## THEME: 2.B.2: Charts and Decision Aids

**TASK 42: Ocean Flow Model Distribution and Accessibility:** Continue working with the TWCWG to develop S100 specifications for how to disseminate, visualize, and make use of ocean flow data from observation and simulation to end-users. This includes feature-aware compression of immense data sets into smaller and thus more easily transmittable snippets, 2D visualization methods that integrate into existing charting environments, and analysis tools to increase the usefulness of this data for users. **PI: Briana Sullivan**

**TASK 43: Chart Update Mashup (ChUM)—Modernization of Data Set Maintenance:** Continue and enhance the Chart Update Mashup effort by integrating other supplemental data with the chart including Coast Pilot data. Continue Digital 3-D Coast Pilot prototype efforts with a focus on using the database from Coast Pilot Branch at OCS and displaying the structured results in a web-based prototype using Google Maps. **PI: Briana Sullivan**

The Sailing Directions (SD)/Coast Pilot (CP), a textual aid to marine navigators, has traditionally been a product distributed in print or as PDFs; a form unable to take full advantage of the detailed georeferenced data it includes. One of our goals as we explore the “chart of the future” is to be able to use supplementary data for the electronic nautical chart (ENC), such as the CP, to augment and add-value to the mariner’s experience. The IHO is in the process of creating standards for ECDIS/ENC called S-100 (replacing the old S-57 standard). The IHO Nautical Information Provisions Working Group (NIPWG) is responsible for the Nautical Textual Information (NTI) contained within the SD/CP. Over the years NIPWG has been working on creating various data layers (S-12x standards) that are contained within the SD/CP that can be displayed on an ECDIS/ENC.

Working to support the mandate of NIPWG we are investigating how to parse the unstructured NTI into structured data models so that this data can be used in electronic chart displays. We are also investigating how well-structured/machine-readable information can be best displayed in an interactive display and to find other ways in which it can be used to support the mariner.

### Project: S-126 NIPWG/Marine Physical Environment

**JHC Participants:** Briana Sullivan, Tianhang Hou, and Kim Lowell

One of the layers of data within the NIPWG purview is the S-126 Marine Physical Environment standard. S-126 is responsible for describing marine and terrestrial topography, prevailing, seasonal, and hazardous currents, tides, weather, and other environmental conditions. Currently, their work contains a list of topics to be covered but lacks a plan for structuring the data. Sullivan has taken the lead for this task in the past few years and has developed a proof-of-concept digital version of a web-based interactive Coast Pilot, called iCPilot, for testing new design ideas for the presentation of NTI among other things. This project highlighted the need for a new data model to structure textual data relating to the physical environment.

iCPilots’ latest upgrades focused on the interoperability between S-111, surface current modeled data and the S-126 NTI that contains only surface current related information and the electronic nautical chart (ENC). The testing area was narrowed down to the entrance of the Chesapeake Bay area (Figure 43-1).

The surface current NTI from Book 3 of the Coast Pilot was collated and iteratively structured to find the best way to overlay it on the ENC. Two categories of NTI were discovered through this process—General Conditions and Warnings. These later formed part of the data model.

Figure 43-1 illustrates the integration of three data sources in iCPilot; the ENC, shown in the background, the UNH portrayal of streamlines for a time-series of S-111 surface current data, and the info-boxes that contain surface current NTI from the Coast Pilot. There are two marker types used as examples to indicate warnings (the red triangles) and general conditions (the blue waves). Each marker has an associated popup Info-box.

Marker 1 in Figure 43-1 is an NTI Info box indicating the general trend for the current velocity at that location, which tells of both the typical ebb and flow at a glance instead of just one time-step in a possible series of data (from the S-111 stan-

standard). Marker 2 points out speed values in a location where there is no S-111 data available.

Marker 3 in Figure 43-1 is an NTI Info box indicating a warning icon for a maximum current that could exceed predicted model's (note: in this time-step the maximum speed at that location is about 1.5 knots). Other Warnings (Marker 4 in Figure 43-1) have vessel size associated with them indicating these parts of the message could be filtered by vessel dimensions.

A white line near Marker 1 in the figure is associated with the general condition marker and shows a feature that does not exist in the ENC (to the entrance of a body of water or waterway) that is needed for full interoperability with the ENC. (The other associated ENC features are shown only when the associated marker is focused on by the mouse pointer).

## A New Data Model

A problem with integrating the NTI, S111, and ENC is a lack of defined linking information. For example, there are numerous references to harbor or channel entrances in the Coast Pilot, but these are not features in the ENC. Full integration requires common features and this requires a data model.

Figure 43-2 shows an initial prototype data model developed at the Center for NIPWG. The S-100 standard model contains two types of objects: geographic features and information objects instantiated in the S-101 ENC. This prototype is an info-object that incorporates the same structure for the purpose of interoperability.

The work for the visualization and data model were presented to the IHO NIPWG6 in Germany in the first half of 2019.

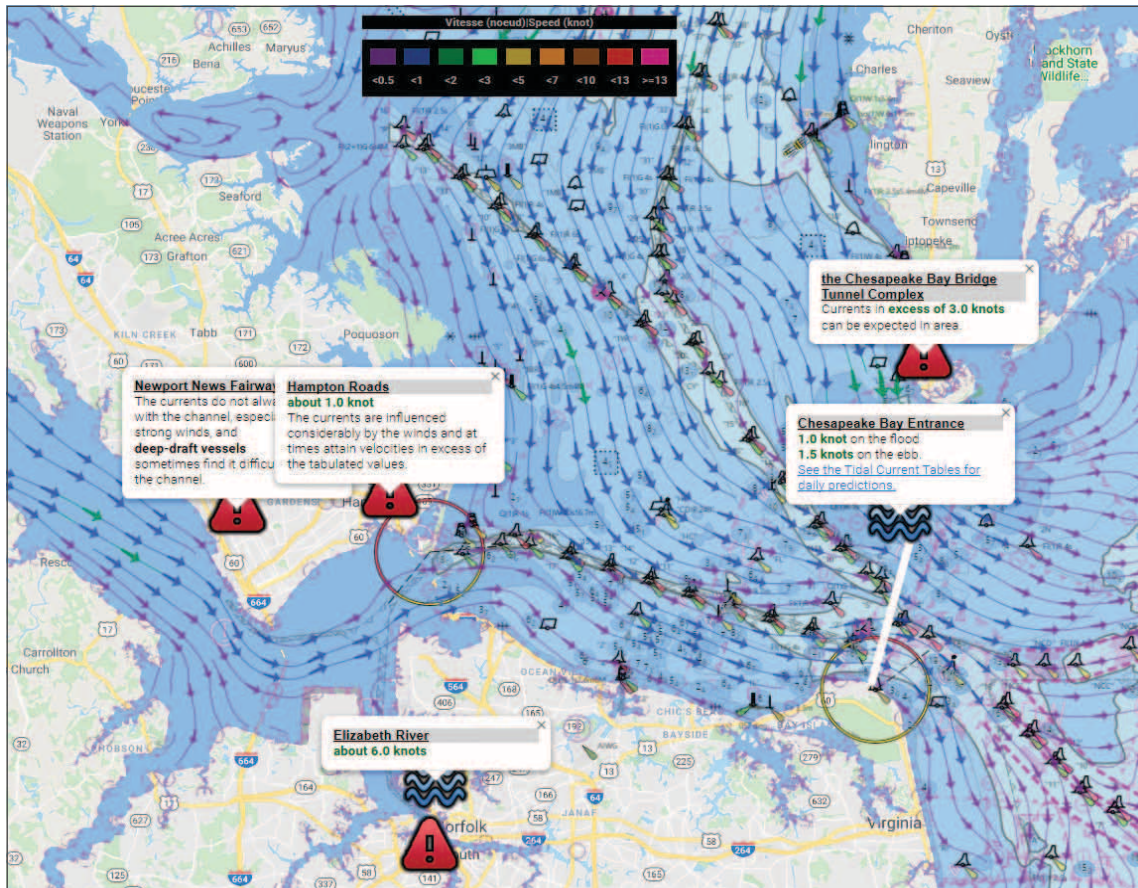

Figure 43-1. ICPilot Prototype showing S-111 surface current data in conjunction with related Coast Pilot textual data.

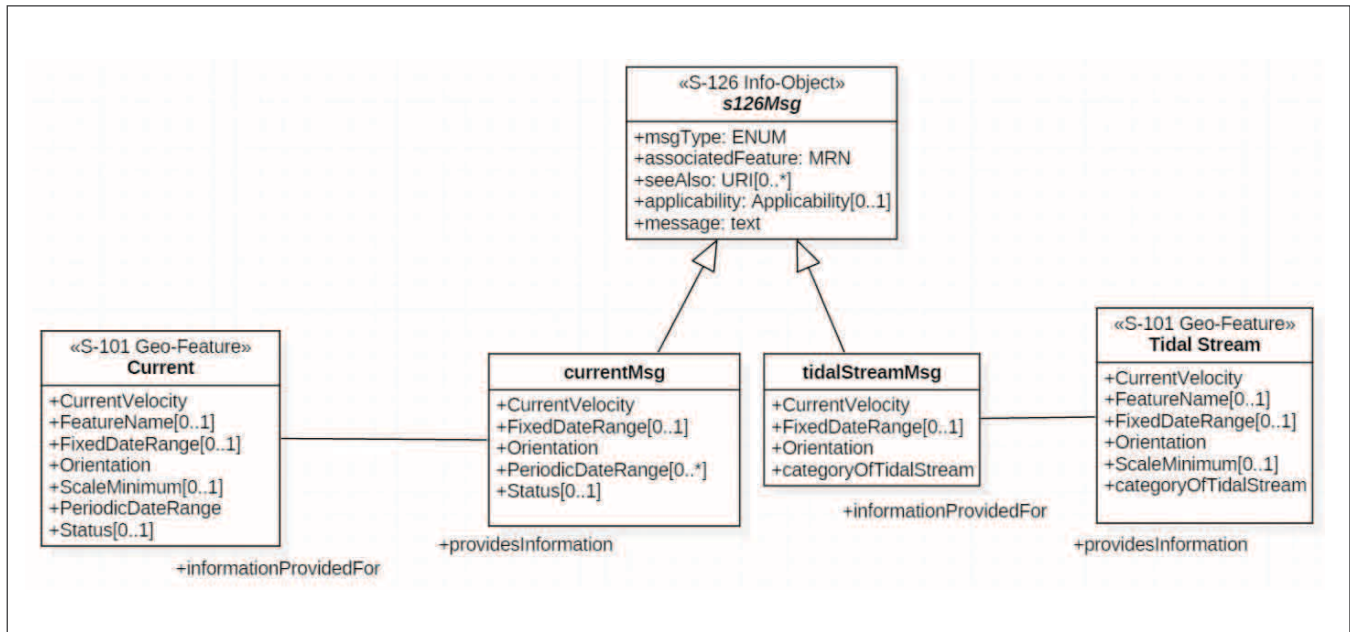

Figure 43-2. Prototype data model designed to support textual data relating to the physical environment presented to NIPWG6.

Halfway through the year, Kim Lowell joined the team to help in processing and analyzing the surface current NTI. The goal of his work is to automatically parse the Coast Pilot to extract textual information

relating to the physical environment so that the data model can be tested for completeness and refined if necessary. He has built a customized parser using Python and the results are currently being evaluated.

### Project: S-127, Marine Traffic Management/Pilot Services Focus

JHC Participants: Briana Sullivan and Tianhang Hou

The work reported in the project “S-126 NIPWG/ Marine Physical Environment” has built a foundation for understanding the process of the work being done on the S-127, Marine Traffic Management. Last year Sullivan reported that the beginning of Pilot Boarding Places data model from the S-127 product specification, was being formed. This year, Sullivan completed a GML S-127 product (with Pilot Services only), following the newly released IHO standard. Along with the creation of the GML product, Sullivan and Hou also set up a

database schema based on the S-127 data structure and populated the tables from the Coast Pilot. When used in conjunction with Python code, it was then possible to automatically generate an S-127 product. This proved to be the first instance of the generation of an IHO S-12x product from the Coast Pilot and the first instance of a tested database schema that would structure the data to be more useful. This work was well received and appreciated at NIPWG7 and we have been working with several HOs to create their own.



**TASK 44: Augmented Reality in Electronic Charting and Navigation:** Research on how to utilize augmented reality devices in support of enhanced navigation. Expand and modify to provide a range of scenarios (collision avoidance, harbor entry, etc.) using our virtual ship simulator. **PIs: Tom Butkiewicz and Vis Lab**

**Project: Augmented Reality for Marine Navigation**

**JHC Participants:** Tom Butkiewicz, Andrew Stevens, and Colin Ware

Augmented reality (AR) is an emerging technology that superimposes digital information directly on top of a user’s real-world view (Figure 44-1). AR may have great potential for aiding safe marine navigation, but the devices currently available have significant limitations that prevent them from being practical for marine usage. While suitable devices are still a few years away, the Center is already researching AR-aided marine navigation through virtual reality simulation.

Thomas Butkiewicz continues to develop a dynamic and flexible bridge simulation (Figure 44-2) for experimenting with a range of possible AR devices and information overlays, across different times-of-day, visibility, and sea-state/weather, allowing for safe evaluation in a more diverse set of conditions than available on our research vessel. The project’s goals include identifying the technical specifications required for future AR devices to be useful for navigation, what information is most beneficial to display, and what types of visual representations are best for conveying that information.

Butkiewicz has completed a physical interface for piloting the virtual boat. The controls include a full-size ship’s wheel that provides realistic force feedback and a throttle. These are mounted to a portable platform with an integrated tracker, which keeps the virtual bridge’s controls and real controls perfectly aligned, such that one can always reach out and grab them within the simulator.

These controls are used by participants to pilot the virtual boat during user studies. The first study was completed this year and focused on understanding the effects of field-of-view on the usefulness of the AR overlays for marine navigation tasks. Second only to brightness (first generation AR devices are not bright enough to use out on a boat during the daytime), field-of-view is the most significant barrier to current AR devices being useful for navigation. The Microsoft Hololens, for example has a very narrow field-of-view of only 30° diagonal. This results in “tunnel-vision,” drastically reducing situational awareness; as the user only sees information about what they are actively looking directly at, and does not see potential hazards outside their current focus.

In this experiment, 20 participants (eight with significant boating experience) piloted the virtual boat along a course of approximately 100 waypoints (buoys) through Portsmouth Harbor. At all times, they were able to view their current target waypoint and line towards it on a traditional ECDIS that displayed a track-up view from OpenCPN charting software. Additionally, during parts of the course, they also were able to view augmented reality overlays that also showed the current target waypoint and a line towards it, drawn directly over the water/buoy in first-person perspective. These overlays were presented at different fields-of-view to simulate the new Microsoft Hololens 2 AR device, as well as two wider-FoV conditions representative of future AR devices with more advanced optics.



Figure 44-1. Simulated augmented reality overlay of nautical chart information.



Figure 44-2. The virtual bridge and AR simulator (left). The physical controls used to pilot the boat (below right). View from the virtual bridge within the field-of-view study environment, showing ship traffic and AR trackline to next waypoint (above right). The virtual ECDIS display above the bridge windows, showing a track-up OpenCPN chart with the same trackline and waypoint.

The simulation was modified to use a head mounted display with an integrated eye-tracker that can accurately detect what participants are looking at 120 times per second. While participants navigated the course, we used the eye-tracker to record how often they looked up at the ECDIS, which is a useful metric for understanding the effects of FoV on situational awareness because keeping one's eyes on the water is the most significant factor in avoiding ship collisions. For further situational awareness metrics, the eye tracker also recorded how often participants looked at surrounding ship traffic that was moving about the harbor, and how quickly they noticed (or if they did not notice) kayakers that were scripted to approach their boat via blindspots.

The results of the study indicated great potential for AR to aid in safe marine navigation by keeping mariner's eyes on the water. Regardless of FoV, when AR overlays were available, participants spent less than half as much time looking at the ECDIS instead of the water, and they overwhelmingly chose to use the AR overlays to find their next target versus looking at the ECDIS, even when narrow FoV conditions required them to scan back and forth.

As predicted, there was a strong correspondence between wider AR fields-of-view and ability to locate and navigate to targets without viewing the ECDIS at all, especially in cases where the next target was signifi-

cantly off-center from the current heading (where it would be out of view in narrower FoV conditions).

Neither AR nor FoV conditions had any significant effect on how long participants spent looking at surrounding ship traffic. Unexpectedly, for spotting kayakers, the narrowest FoV AR condition actually performed the best (fewest unseen kayakers). This is likely due to how a narrow FoV results in users scanning the water to find their target, which increases the chance they will notice the kayaker, whereas with a wider FoV, they are able to acquire the target quickly, and then fixate on it, thus spending less time looking around the water. While these results did not indicate any significant increase in situational awareness of ship traffic and light watercraft, the AR overlays in this study did not provide any visual cues to draw attention to them, as an actual AR navigation system most certainly would.

Butkiewicz and Ph.D. student Drew Stevens also got a chance to physically evaluate a Magic Leap One AR device, but confirmed their assumptions that it did not have enough field-of-view or brightness for marine navigation usage. We hope to acquire a HoloLens 2 unit in 2020, and intend to convert parts of our simulation's interface into a working prototype. This will allow us to demonstrate the system in situ for mariners (to elicit feedback) and see how our visualizations work in the real world.

## Research Requirement 2.C: Visualization and Resource Management

**FFO Requirement 2.C:** “Improvement in the visualization, presentation, and display of hydrographic and ocean and coastal mapping data, including 4-dimensional high resolution visualization, real-time display of mapping data, and mapping and charting products for marine navigation as well as coastal and ocean resource management and coastal resilience.”

### THEME: 2.C.1: General Enhancement of Visualization

**TASK 45: Tools for Visualizing Complex Ocean Data:** Continue our work producing novel 2D, 3D, and 4D visualization solutions that address the unique needs of coastal and ocean applications. This work will focus on: developing novel visualization and interaction techniques; conducting human factors studies to understand the perceptual issues critical to creating successful visualizations, and; improving existing marine data visualization applications based on these findings. **PIs: Colin Ware, Tom Butkiewicz, and Vis Lab**

#### Project: Vector Magnitude Misperceptions Through Stereoscopic Viewing

**JHC Participants:** Andrew Stevens, Colin Ware, and Thomas Butkiewicz

Vector field visualizations are commonplace in oceanic and atmospheric sciences, and stereoscopic 3D can greatly enhance the perception of these visualizations. However, there are many complex factors involved in generating correct stereo imagery, and distortions can be easily introduced.

We have identified a gap in the perceptual literature concerning 3D stereoscopic viewing of vector field visualizations. Filling this knowledge gap will help to strengthen our understanding of the perceptual

mechanisms at play in 3D visualization environments and help to guide our development of more effective visualization tools.

To this end, we carried out a study which evaluated vector glyph length judgment under correct and incorrect stereoscopic viewing conditions and compared the results to the predictions made by a geometric distortion model (Figure 45-1). Our results showed observed errors following a far more complex pattern than predicted by the

geometric distortion model, and that head-coupled stereoscopic viewing (a.k.a. Fishtank Virtual Reality) only provides a modest benefit in reducing glyph length judgment errors at more oblique viewing angles to the 3D display. This research has revealed some interesting perceptual effects we could not explain through our initial experiment, so we plan to develop this research further and collect more data to address those questions.

This past year we have completed a revised paper with the results of this experiment, entitled “Vector Magnitude Misperceptions through Stereoscopic Viewing,” and are preparing to submit it for publication.

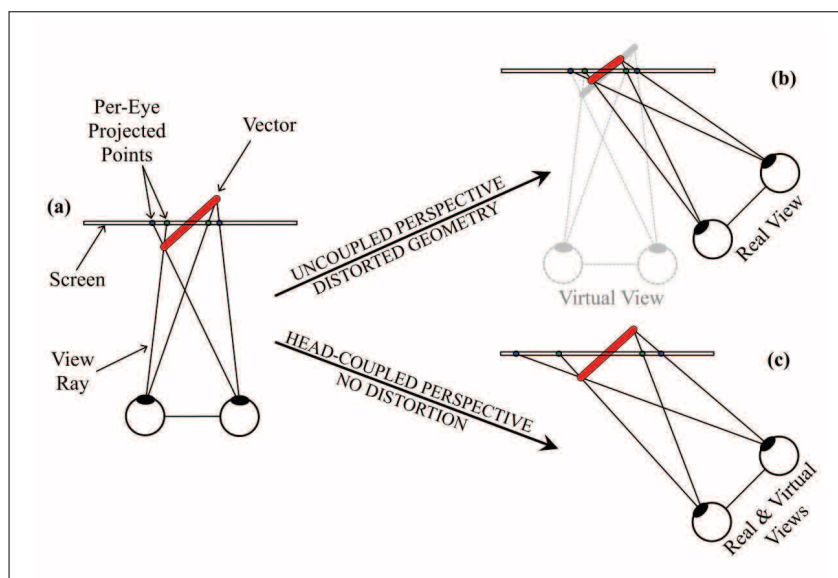
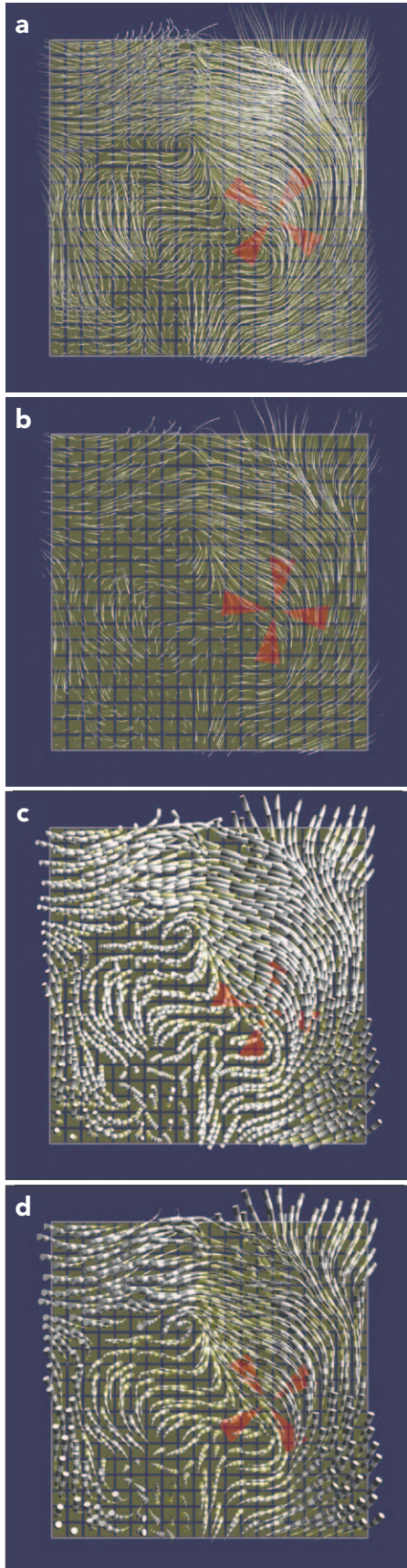

Figure 45-1. Correct stereoscopic viewing on a desktop monitor requires the user’s view and the virtual projection to match (a), (c); otherwise the vector glyph length (red) will appear distorted (b) because the visual system receives incorrect information about the 3D scene.





### Project: Immersive 4D Flow Visualization

JHC Participants: Colin Ware, Andrew Stevens, and Thomas Butkiewicz

Many oceanographic datasets with application to hydrographic practice are intrinsically four-dimensional (e.g., currents, wave fields, wind). Visualization of such fields so that they are readily interpretable is not straightforward. In many cases, the data is very dense, and users have difficulty in interpreting the direction and magnitude of flow when the data is represented at a scale that allows for useful rendering on screen. Techniques to allow for clear interpretation while preserving the complexity of the flow are therefore essential if these datasets are to be used in practice. We have therefore been building upon our previous flow visualization research by experimenting with new techniques and interactive technology to determine how they can be applied to benefit 4D flow visualization and analysis.

Stevens has extended the Center's existing experimental 4D flow visualization software to add interactivity to the previously static glyph-seeded cutting planes that were found to be effective in previous perceptual studies. Because recalculating complex glyphs such as streamtubes is computationally expensive, it is challenging to be able to recalculate them 60+ times per second, which is necessary to maintain smooth interactivity and rendering framerates. As such, the data and calculations have now been moved from the CPU to the GPU. This change has provided an orders-of-magnitude increase in performance.

These interactive cutting planes were used in a perceptual study designed by Ware to evaluate different visual parameters (e.g., streamline geometries, textures, stereoscopic viewing, and motion) to perceptually optimize the viewing of 3D/4D flow data through cutting planes, a continuation of prior work in the Center's visualization lab.

The controlled experiment found that stereoscopic viewing provided a clear benefit to perceiving 3D flow direction through a cutting plane but oscillating the plane to provide structure from motion (SfM) cues did not improve flow perception. Animating textures along streamline geometries helped to disambiguate flow direction, and cone-type 3D streamline geometries, shown in Figure 45-2(d), exhibited strong perceptual performance across the experimental conditions, followed by tube-style geometries, shown in Figure 45-2(c).

A paper describing these findings, entitled "Hairy Slices II: Depth Cues for Visualizing 3D Streamlines Through Cutting Planes" was submitted for publication in *IEEE EuroVis 2020*.

Figure 45-2. The glyph designs evaluated in the study, from top: (a) Static streamlets. (b) Animated streamlets. (c) Streamtubes with gradient texture. Flow direction is from dark to light. (d) Streamcones. Flow direction is from the base to the tip.

## Project: **BathyGlobe**

JHC Participants: Colin Ware, Paul Johnson, and Larry Mayer

The BathyGlobe is a project (started in 2018) that is being developed for the display of global bathymetric data. One of its goals is to provide support for the Seabed 2030 initiative to heighten awareness of the extent to which the ocean floor has and has not been mapped. The BathyGlobe can be used with a high resolution (4K) touch-screen in order to show high resolution images of the seafloor with load times that appear instantaneous. The current state of the project is shown in Figure 45-3.

A touch on part of the globe selects that region and causes the globe to rotate so that the indicated region is centered, and a higher resolution view of the area appears to the upper right in a stereographic projection. The lower right quadrant shows a 3D view that is at the full data resolution.

There were several iterations of the BathyGlobe software in 2019. Version 1.7 included the incorporation of the entire GMRT multibeam database. This was done by writing code to directly access the GMRT files (which are stored in a compressed Mercator form), resample them into geographic coordinates, and compress them. The compression method involves multiplying the depths by five and converting to an unsigned 16-bit integer. Lossless PNG compression is then applied. The result is that the entire database currently uses 3.4 GB with a maximum error on a single point of 10 cm. But two adjacent points could each have a 9.99 cm error. So the error of the difference between adjacent depths (or quantization uncertainty) will be < 20 cm.

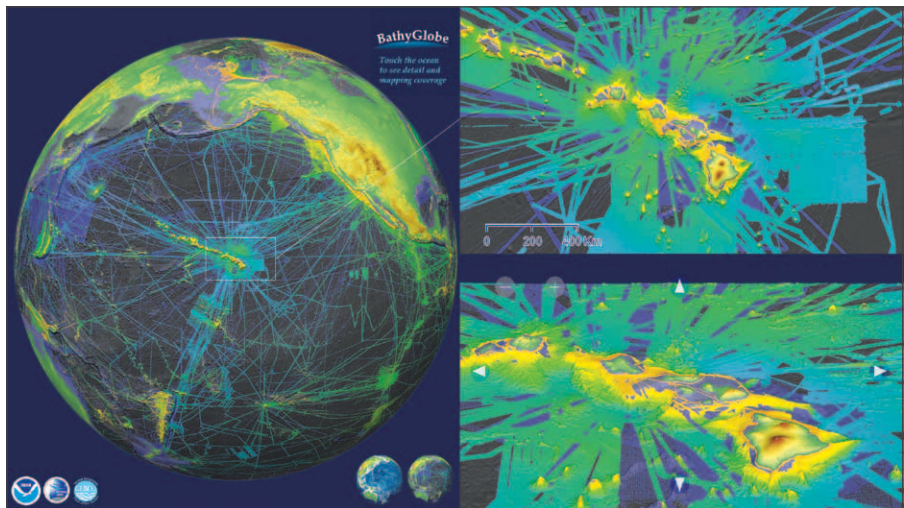

Figure 45-3: BathyGlobe, showing the newest GEBCO 2019 data with a colormap designed to emphasize areas with multibeam coverage.

## Project: **Global Geographic Grid System (GGGS)**

JHC Participants: Colin Ware, Paul Johnson, and Larry Mayer

The GGGS, used in BathyGlobe, allows for display of data at any resolution. Seabed 2030 requires that the oceans be mapped at different resolutions depending the depth. This is because the resolving power of multibeam sonars on surface ships decreases as a function of depth. This means that for reasons of storage and visualization efficiency, it is important that a method be developed that can support different data resolutions. In addition, even once the seabed has been fully mapped, some regions of the ocean will be mapped at much higher resolutions than others, and GGGS can support this.

First described in the 2018 progress report, the Global Geographic Grid System (GGGS) for visualizing bathymetry has now been fully designed and implemented. GGGS was developed to address

the needs of the seabed 2030 project and for other applications where a geographic grid is desirable. A first draft was submitted to the Seabed 2030 Technical Committee in January 2019, and a revised version was submitted in April 2019. The system has been discussed at a number of technical group meetings and was presented at the Arctic-Antarctic Mapping meeting in November 2019.

GGGS combines a metagrid hierarchy with a system of compatible data grids. Metagrid nodes define the boundaries of data grids. Data grids are square grids of depth values. Both metagrids and data grids are defined in geographic coordinates to allow broad compatibility with the widest range of geospatial software packages (Figure 45-4). An important goal of the GGGS is to support the meshing of adjacent tiles

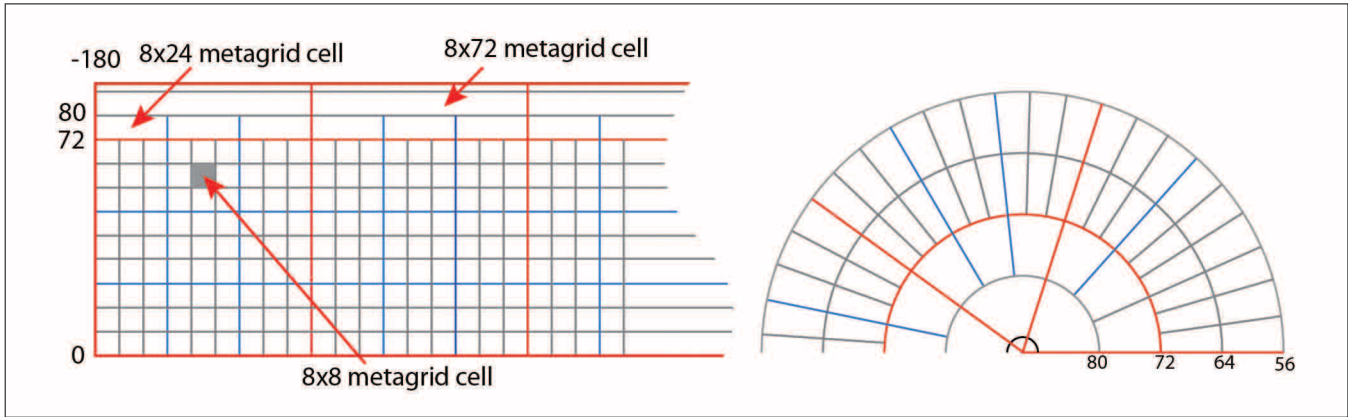

Figure 45-4. An illustration of part of the global metagrid. On the left, it is shown in a standard geographic view. On the right is a polar view.

with different resolutions so as to create a seamless surface. This is accomplished by ensuring that abutting data grids either match exactly or only differ by powers of two.

The system supports differently sized data grids in a way that is independent of resolution. It is useful to have large tiles to represent large areas of the sea floor mapped at a constant resolution, but grids that are very large are slow to load and display and are therefore difficult to handle in most interactive display systems. Smaller grids are space efficient for areas of the seafloor mapped at different resolutions, but numerous small grid tiles are also not efficient to render in computer graphics, since a large number of tiles must be managed. For this reason, GGGs grids are constrained in both minimum and maximum size.

The GGGs also supports the seamless meshing of low-latitude data with polar data sets. Often, polar data sets use a different projection than the projection used for data at lower latitudes, creating difficulties in displaying datasets that cross the boundary. In the GGGs, Arctic, sub-Arctic, Antarctic, and sub-Antarctic datasets are supported in essentially the same way.

The basic principle of polar grid construction is that the number of grid columns decreases by powers of two as distances between lines of longitude decrease by a factor of two. The first such boundary is at 60°, where lines of latitude have half the spacing that they do at the equator. The next is at approximately 75°, where lines of longitude halve again. The third transition is above 82.5°, where data grids have 1/8th the number of columns per degree relative to rows.

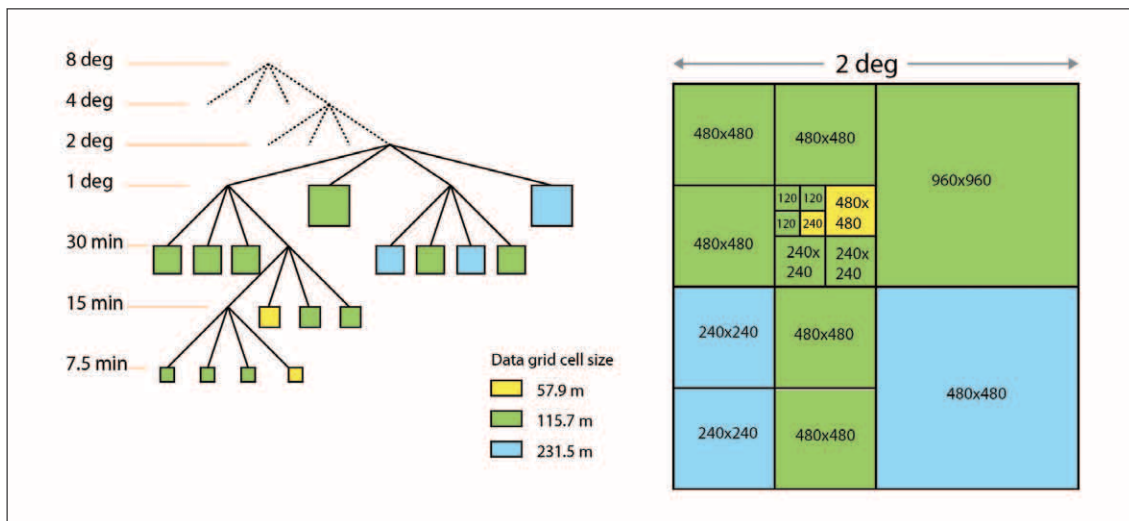

Figure 45-5. An example of a quadtree metagrid hierarchy. To the left, as a standard tree diagram. To the right, the same structure is shown as a map. Different resolutions are color coded.



## Implementation

Much of the effort has been devoted to building a proof-of-concept implementation of GGS using C++ and OpenGL. The implementation has three main classes:

**GGSroot** has the responsibility of implementing the global metagrid shown in Figure 45-4. As data is loaded, it creates a top level metaGridNode at the appropriate location and inserts the data. This hands the responsibility of building a quadtree for that 8°x 8° location to an instance of the metaGridNode class.

**metaGridNode** has the responsibility of implementing the quadtree metagrid hierarchy as illustrated in Figure 45-5. As data nodes are inserted, the quadtree structure is built to the appropriate depth depending on the size of a data node. A pushdown function subdivides high-level low-resolution nodes so that they fill in around high-resolution nodes, as illustrated in Figure 45-6. In this example, the data tiles are shown without the polygon strips that tie them together, so as to reveal the structure.

MetaGridNodes also have the responsibility of building the polygon strips that tie together adjacent tiles, although the rendering is done by the bathyGrid nodes.

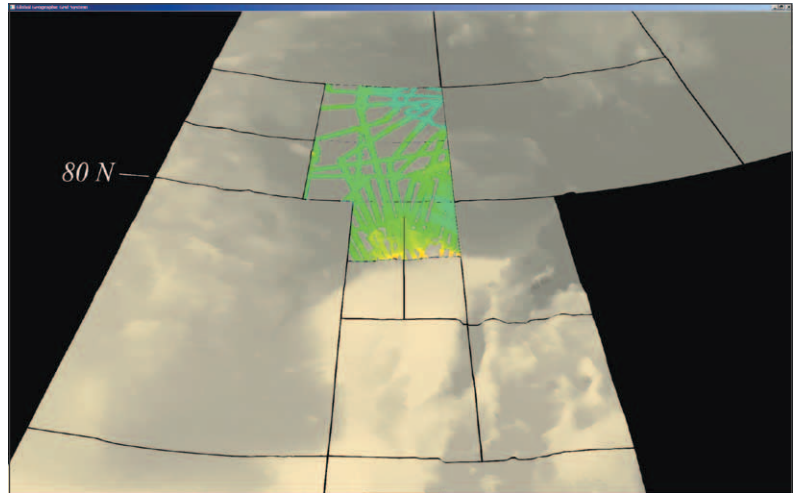

Figure 45-6. An example of a metagrid structure above and below the 80° N contour. The grey areas have been subdivided to fill in around the high-resolution data.

**bathyGrid** implements bathymetric data grids. These are loaded, transformed into an orthographic projection centered on a designated focus point, and rendered. This class has an 8-bit attribute layer in addition to the bathymetric grid, and the attributes can be shown by means of multiple colormaps (currently up to eight are supported). Examples are shown in Figures 45-6 and 45-7. A vivid high-saturation colormap is used to highlight the areas where multibeam bathymetric data exists. BathyGrid also has the responsibility of constructing surface normals for the data grids and rendering both the data grids and the connecting strips.

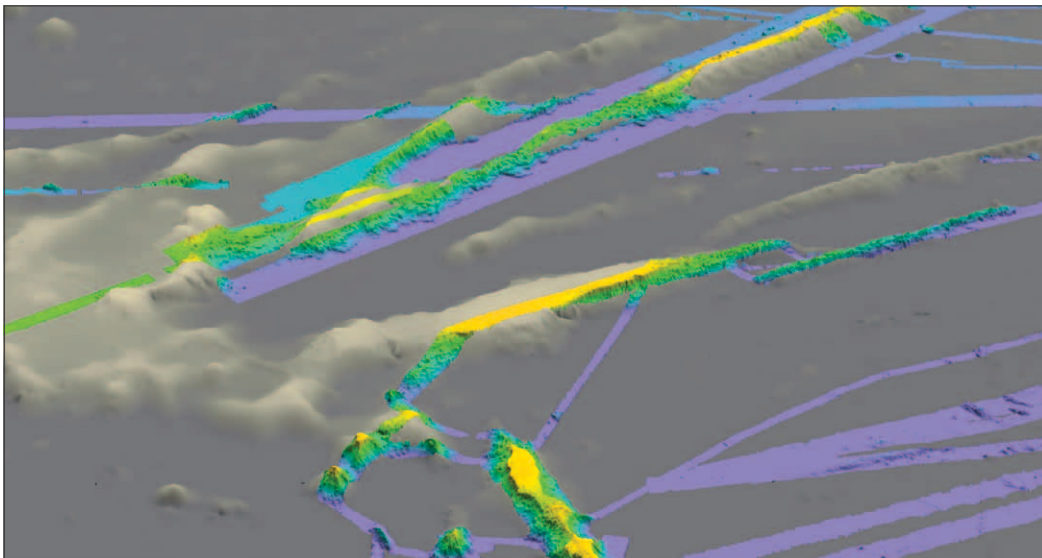

Figure 45-7. Two colormaps applied according to an attribute layer in GGS.

## Programmatic Priority 3: Explore and Map the Continental Shelf

### Research Requirement 3.A: Extended Continental Shelf

**FFO Requirement 3.A:** “Advancements in planning, acquisition, understanding, and interpretation of continental shelf, slope, and rise seafloor mapping data, particularly for the purpose of delimiting the U.S. Extended Continental Shelf.”

**TASK 47: Lead in Planning, Acquiring and Processing ECS Bathymetric Data:** *Maintain role as lead in the planning, acquisition, and interpretation of ECS bathymetric and backscatter data, applying advances in acoustic system calibration and operational “best practices” developed in support of other Program Priorities to improve the quality of data collected on the continental shelf, slope, and rise, with particular regard for the Center’s involvement in ocean exploration campaigns aboard the NOAA Ship Okeanos Explorer (both at sea and via telepresence) and other ECS mapping projects. Pls: Jim Gardner and Larry Mayer*

#### Project: Planning and Acquiring ECS Data

**JHC Participants:** Jim Gardner, Larry Mayer, David Mosher, Brian Calder, and Paul Johnson

**NOAA Collaborators:** Andy Armstrong, OCS; and Margot Bohan, OER

Recognition that the implementation of the United Nations Convention on the Law of the Sea (UNCLOS) Article 76 could confer sovereign rights to resources over large areas of the seabed beyond the current U.S. 200 nautical mile (nmi) Exclusive Economic Zone (EEZ) focused interest in the potential for U.S. accession to the Law of the Sea Treaty. In this context, Congress (through NOAA) funded the Center to evaluate the content and completeness of the nation’s existing bathymetric and geophysical data holdings in areas surrounding the nation’s EEZ with an emphasis to determine the usefulness of the existing data to substantiate the extension of resource or other national jurisdictions beyond the present 200 nmi EEZ limit into the UNCLOS-defined Extended Continental Shelf (ECS). This report was submitted to Congress on 31 May 2002.

Following the recommendations made in the above report, the Center was funded (through NOAA) to collect new multibeam sonar (MBES) data in support of a potential ECS claim under UNCLOS Article 76. Mapping efforts started in 2003 and since then the Center has collected more than 3.1 million km<sup>2</sup> (>1.2 mi<sup>2</sup>) of new high-resolution multibeam sonar data on 35 dedicated cruises that include nine in the Arctic, five in the Atlantic, one in the Gulf of Mexico, one in the Bering Sea, three in the Gulf of Alaska, three in the Necker Ridge area off Hawaii, three off Kingman Reef and Palmyra Atoll in the central Pacific, five in the Marianas region of the western Pacific and two on Mendocino Fracture Zone in the eastern Pacific (Figure 47-1). Summaries of each of these cruises can be found in previous annual reports and detailed descriptions and access to the data and derivative

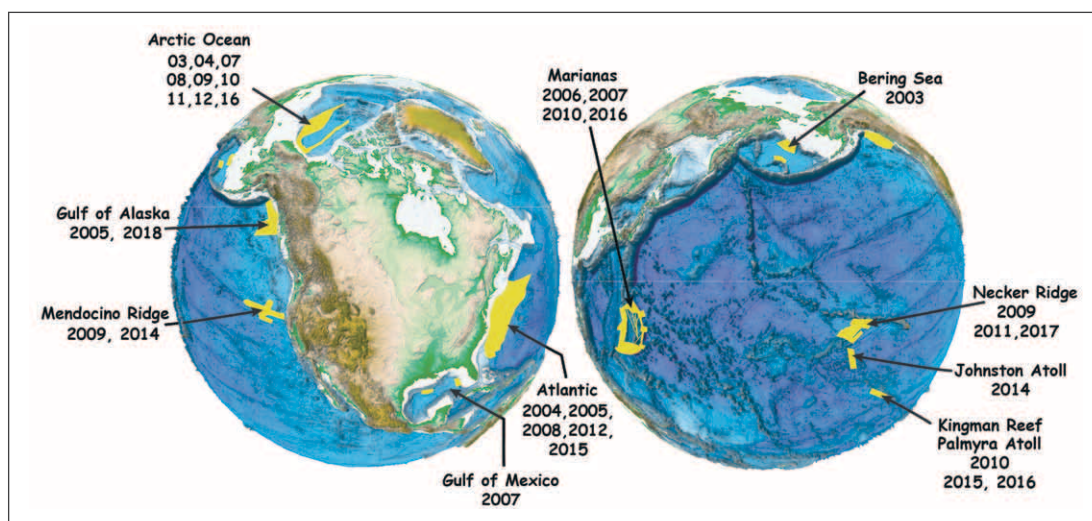

Figure 47-1. Locations of ECS multibeam sonar surveys conducted by the Center.

products can be found at [http://www.ccom.unh.edu/law\\_of\\_the\\_sea.html](http://www.ccom.unh.edu/law_of_the_sea.html). The raw data and derived grids are archived at NOAA's National Center for Environmental Information (NCEI) in Boulder, CO and other public repositories within months of data collection and provide a wealth of information for scientific studies for years to come.

### 2019 Law of the Sea Extended Continental Shelf Activities

Extended Continental Shelf activities in 2019 focused on the generation of histograms of multibeam depth uncertainties based on cross lines run on each cruise, creating DOIs (Digital Object Identifiers) for each ECS cruise, the evaluation and re-gridding of legacy data sets to be fused with the data collected by the Center into ECS analysis grids, the generation of manuscripts on data collected in the U.S. ECS, the updating and revision of the Center's Law of the Sea website, and supporting the ECS Program Office through requests and numerous conference calls. No ECS cruises were run during 2019 and none are envisioned for the future.

### Revising the Center's ECS Website

Paul Johnson, the Center's Data Manager, and Jim Gardner are in the process of revising the Center's ECS website. The revision entailed the generation of new grids of all the ECS bathymetry and backscatter grids, application of a standard color map to each new grid and the creation of various images of interesting features in each ECS area. All that work

was completed in late 2018 but a major obstacle presented itself in late 2018 and early 2019 just as the task was nearing completion.

The stumbling block is the requirement for the creation of DOIs. A DOI must be included in each of the metadata files created for each data type for each cruise for our data to be archived at NOAA/NCEI. In the past, NOAA/NCEI, NSF/R2R and Lamont's GeoMapApp groups have all generated DOIs for our data and posted the DOIs on their various websites but there have been issues with this process and, most recently, we have been informed that NCEI can no longer generate DOIs for the Center. This led Gardner and Johnson to investigate how the Center can generate DOIs, and had progressed to the early stages of working directly with NCEI to develop a schema that would allow the Center to create DOIs for inclusion in all our raw files, processed line files, grids, raw subbottom seismic data, cruise reports, etc. However, the University of New Hampshire decided that the university should be the generator of any DOI for all data and derivative products by university employees.

This has been a complex and drawn-out process but in late November 2019 the University finally produced six DOIs for one cruise. Johnson and Gardner are now beginning the process of modifying the metadata software to include the DOIs for this cruise. The Center has run 35 ECS cruises since 2003, which together, requires 210 separate DOIs; we are exploring ways to expedite the process.

**TASK 48: Extended Continental Shelf Task Force:** *Continue to play an active role in ECS Taskforce activities, as well as to work on the analysis and documentation needed to delineate the U.S. Extended Continental Shelf and continue to publish geologic and morphologic interpretations of the mapped regions in the peer-reviewed scientific literature. PIs: **Jim Gardner, Larry Mayer, and David Mosher***

### Project: 2017 ECS Meetings, Manuscripts, and Analyses

**JHC Participants:** Jim Gardner, Larry Mayer, David Mosher, Paul Johnson, and Brian Calder

**NOAA Collaborators:** Andy Armstrong (OCS), Margot Bohan (OER), Elliot Lim and Jennifer Jencks (NCEI)

**Other Participants:** Brian van Pay and Kevin Baumert (U.S. State Department)

Numerous ECS conference calls, videoconferences, and meetings occurred throughout the year. Monthly ECS Working Group conference calls were scheduled to review overall ECS progress, supported by unscheduled phone calls and videoconferences to

discuss specific regional details. Of particular importance was a major ECS Planning Meeting held in Colorado in May of 2018 and the Arctic 5 meeting held also held in Colorado in December. Both were attended by Andy Armstrong and Larry Mayer.



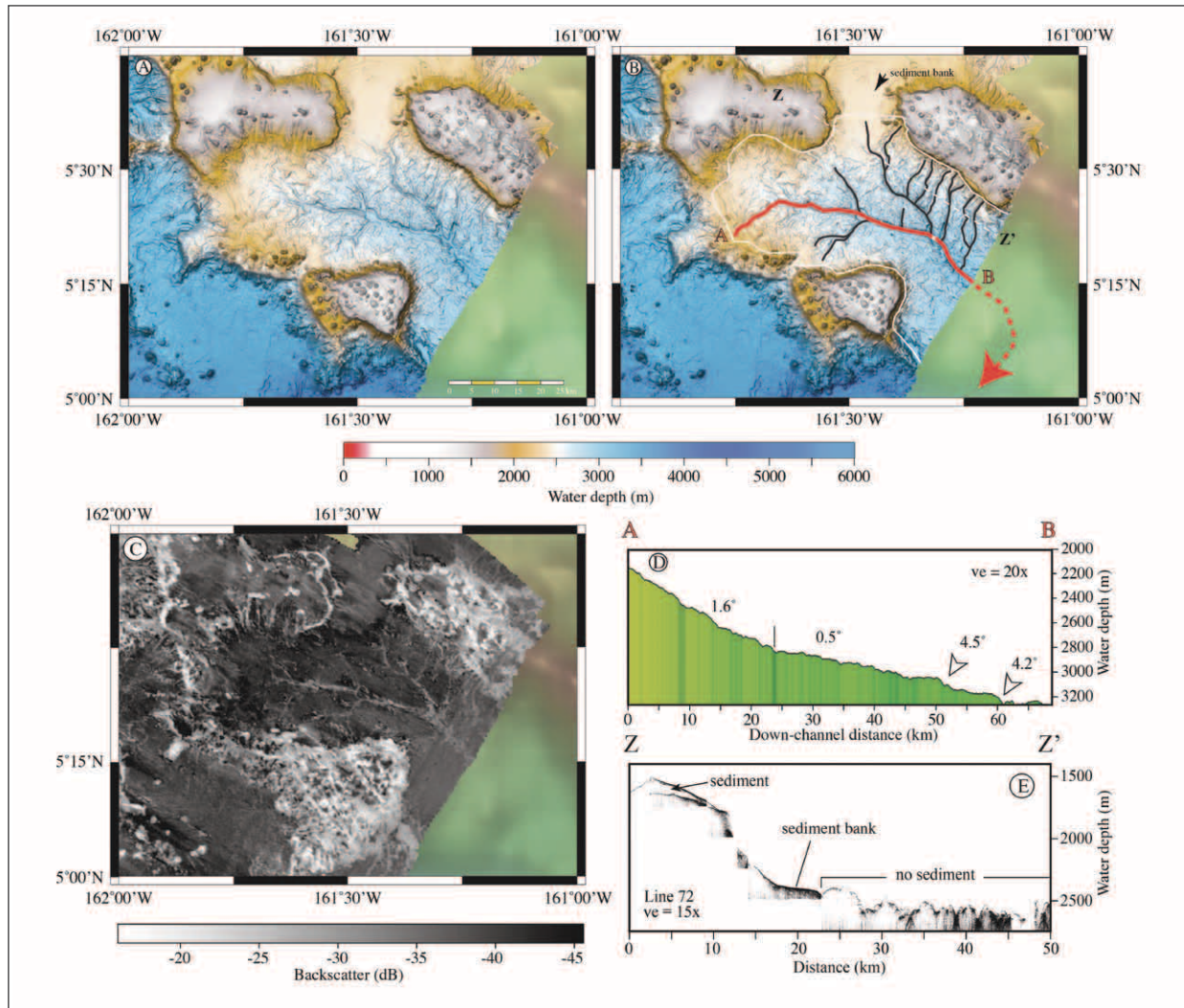

Figure 48-1. (A) Map view of multibeam bathymetry of channel system D. (B) The same area as (A) with main channel traced in red with a white dot marking 50-km down channel and tributaries traced in black. (C) Same area as (A) showing the multibeam acoustic backscatter of channel system D. (D) Profile A-B of the down-channel distance along the main channel. White arrowheads point to two significant channel descents. (E) Subbottom seismic line 72 shown in map view (B) as white dashed line Z-Z'.

### Manuscript Writing

Jim Gardner has submitted a manuscript based on ECS data collected in the vicinity of the Line Islands, co-authored with Jeffrey Peakall, Andrew Armstrong and Brian Calder (*Gardner et al., in revision, The Geomorphology of Submarine channel systems of the northern Line Islands Ridge, central equatorial Pacific Ocean*) to a peer-review journal in early 2019. We are awaiting reviews.

The manuscript describes the geomorphology of six channel systems that occur on the Line Islands

Ridge in the central equatorial Pacific that were mapped on ECS three cruises. The channels were identified in a fusion of the Center's ECS-collected MBES bathymetry and legacy MBES bathymetry downloaded from NOAA/NCEI. The surprising aspect of the channel systems is not only how well developed they are, with extensive dendritic tributary systems (Figure 48-1), but that the channels are developed on an oceanic ridge that formed by extensive mid-plate volcanism far from any landmass. The channels are extensive and cover a huge

area on the ridge (Figure 48-2). An analysis by Gardner of the guyots (flat-topped seamounts) in the area shows that the northern Line Islands Ridge was once a large archipelago with at least 28 subaerial volcanic mountains at some period in its 86 to 68 Ma history. The mountains had a significant range in heights but were eventually eroded flat at various times as each mountain subsided to and beneath sea level. Now, only Kingman Reef and Palmyra Atoll remain above sea level (see Figure 48-2). But the question is, when

and how did the channel systems develop? The answer to that question is still being pondered by Gardner and his co-authors but they have developed and reported several hypotheses.

Gardner has started writing a second manuscript based on some of the Center's ECS data from Necker Ridge immediately south of the Hawaiian Ridge. The second manuscript is co-authored with Andrew Armstrong and Brian Calder with a tentative title of Landslides and

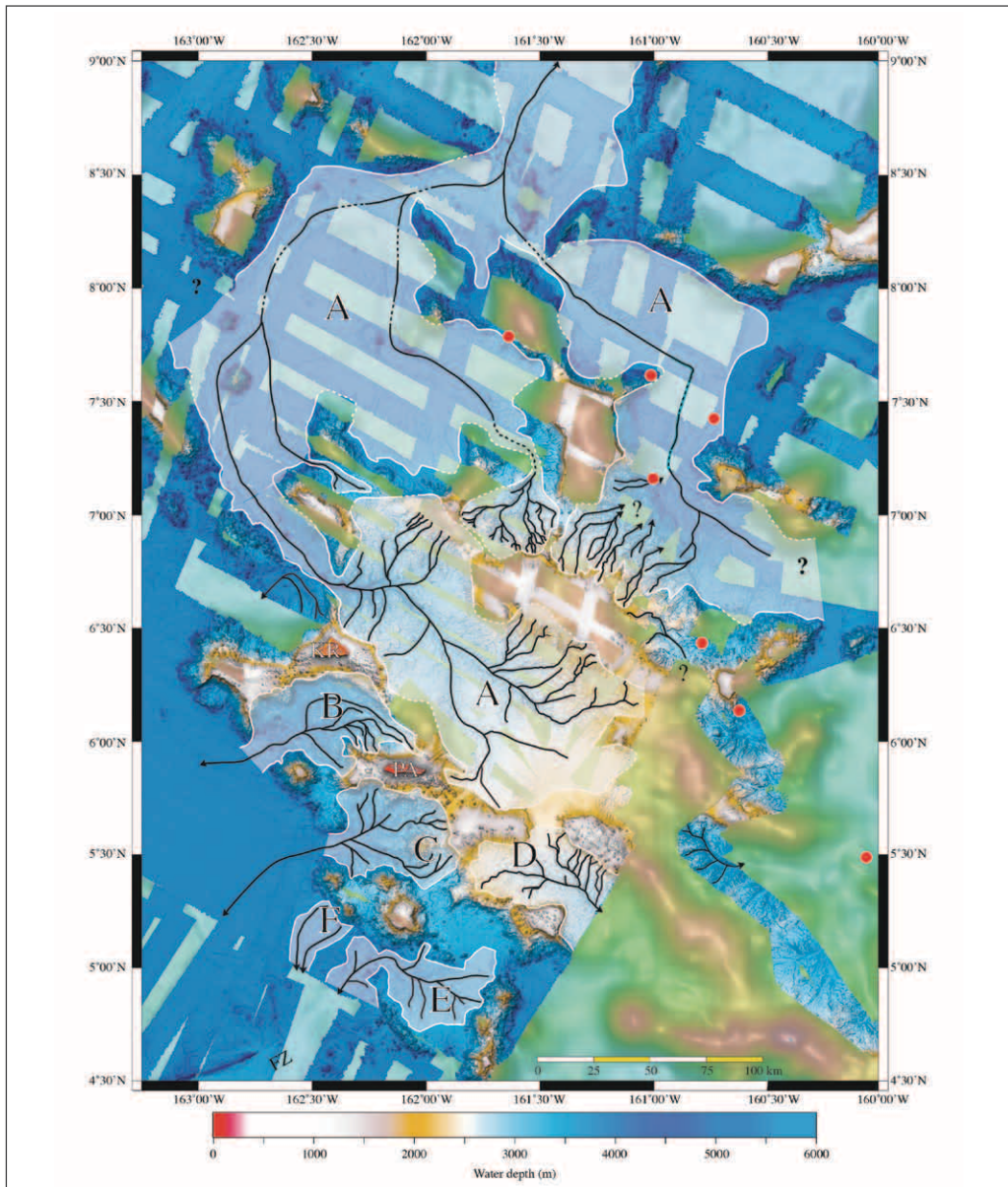

Figure 48-2. Map view of the multibeam bathymetry of northern Line Islands Ridge. Channels are traced in black and six channel systems (A, B, C, D, E and F) identified with red capital letters. Locations shown for Kingman Reef (KR) and Palmyra Atoll (PA). FZ is an unnamed fracture zone.



Archipelagic Aprons off the Southern flanks of French Frigate Shoals and Necker Island, Hawaiian Ridge. The main focus of the manuscript is to describe the debris avalanches that have been shed off the south flanks of French Frigate Shoals and Necker Island on the Hawaiian Ridge since the ridge migrated away from the Hawaiian hotspot. The extensive archipelagic aprons mapped on the southern flanks of French Frigate Shoals and Necker Island are shown in Figure 48-3. The archipelagic aprons are composed of landslides

with outrunner blocks and extensive fields of sediment creep. The outrunner blocks are large intact pieces of the island flanks that, driven by gravity, have been rapidly transported intact down the island flanks and out onto the abyssal seafloor without disintegrating (Figure 48-4). Sediment creep, also driven by gravity, represents the slow transport of sediment that has worked its way down the flanks and out onto the abyssal seafloor, some farther than 100 km beyond the base of the flank.

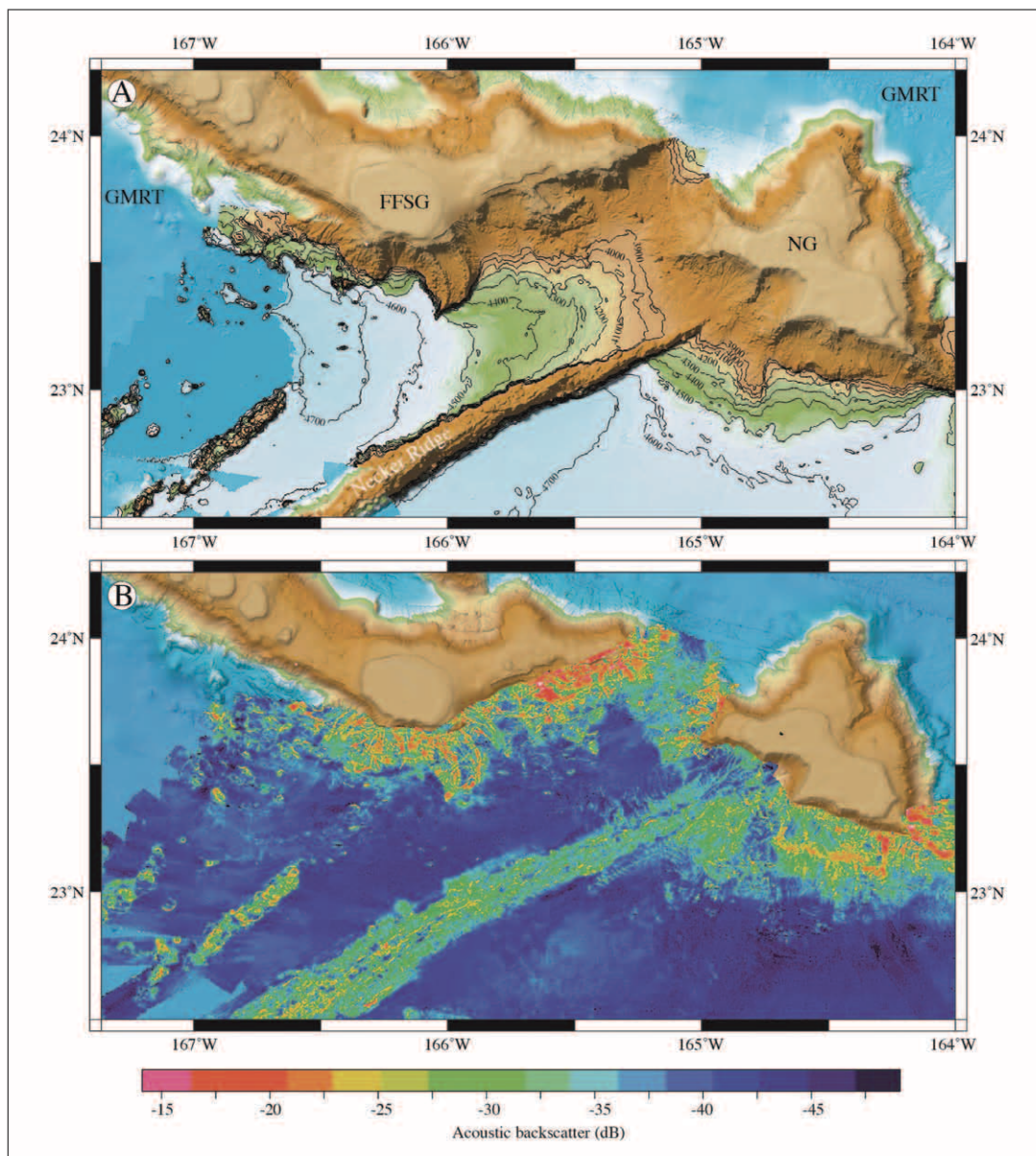

Figure 48-3. Map view of MBES bathymetry of archipelagic aprons on the south flanks and adjacent abyssal seafloor of French Frigate Shoals (FFS) and Necker Island (NI) on the Hawaiian Ridge.



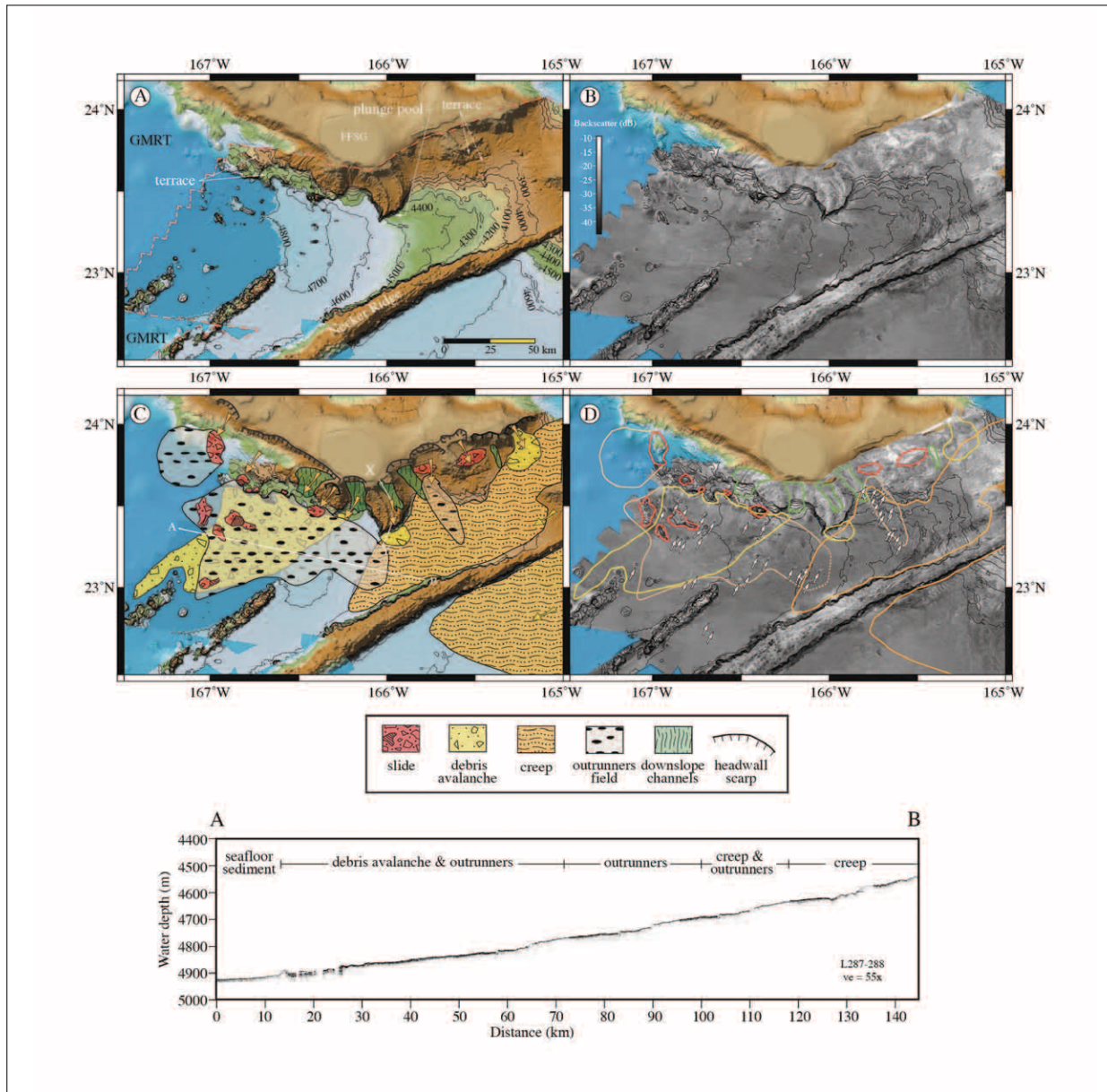

Figure 48-4. The archipelagic apron on the south side of French Frigate Shoals that shows the large isolated intact outrunner blocks (white arrows) from the flanks of the shoal that litter the seafloor. Profiles A-B and C-D show the gentle gradients that provided the inertial force that transported the blocks.

## Research Requirement 3.B: Ocean Exploration

**FFO Requirement 3.B:** “Development of new technologies and approaches for integrated ocean and coastal mapping, including technology for creating new products for non-traditional applications and uses of ocean and coastal mapping.”

**TASK 49: IOCM:** *Maintain an Integrated Ocean and Coastal Mapping Processing Center to support NOAA’s IOCM efforts while developing new tools and protocols for multiple applications of seafloor mapping data.*

**PIs:** **IOCM Team**

A critical component of the Center’s effort has been to host an Integrated Ocean and Coastal Mapping Processing Center that supports NOAA’s focused efforts on Integrated Ocean and Coastal Mapping as outlined in the Coastal and Ocean Mapping Integration Act of PL 111-11. The IOCM Center brings to fruition years of effort to demonstrate to the hydrographic community that the data collected in support of safe navigation may have tremendous value for other purposes. It is the tangible expression of a mantra we have long espoused; “map once—use many times.” The fundamental purpose of the Center is to develop protocols that turn data collected for safety of navigation into products useful for fisheries habitat, environmental studies, archeological investigations and many other purposes, and conversely, to establish ways to ensure that data collected for non-hydrographic purposes (e.g., fisheries, ocean exploration, etc.) will be useful for charting. Our goal is to have NOAA employees from several different NOAA lines and divisions (NOS Coast Survey, Sanctuaries, Fisheries, Ocean Exploration, etc.) at the Center and have them work hand-in-hand with Center researchers to ensure that the products we develop at the Center meet NOAA needs. The NOAA employees will develop skills in the use of these products so that they can return to their respective divisions or the field as knowledgeable and experienced users.

Working under contract to NOAA, a team led by Juliet Kinney have been partnering with a number of Center staff members to design workflows for IOCM products and to provide a direct and knowledgeable interface with the NOAA fleet to ensure that we address high-priority issues and that the tools we develop are relevant for fleet use. This effort received a boost from a separate grant and contract directed to look at the impact of Super Storm Sandy and brings much greater depth to our IOCM efforts as almost all of the work of the Super Storm Sandy (now the IOCM Team) team fits well within the context of the IOCM theme. This pairing epitomizes the concept of IOCM and of bringing research to operations. The team built on research already being done in the Center to develop algorithms and protocols specifically designed for the Super Storm Sandy effort. The IOCM Team continues to apply these tools to produce a series of products of direct relevance to NOAA charting through a separate NOAA contract. The Center provides physical space and logistical support for NOAA IOCM personal and Center personnel continually interact with NOAA personnel assigned to the IOCM Processing Center, but reports on the efforts of the NOAA IOCM Team are not included in this submission.

**TASK 50: ECS Data for Ecosystem Management:** *Explore the applicability of ECS data for the mapping of regional habitat in support of ecosystem-based management. Attempt to generate marine ecological classification and habitat prediction maps with close attention to Habitats of Particular Concern (HAPCs) such as deep-water corals. The protocols developed for analyzing the Atlantic ECS data will then be available for application to other ECS data sets. PIs: Jenn Dijkstra and Larry Mayer*

The Center has led in the acquisition of more than 3.1 million square kilometers of high-resolution multibeam bathymetry and backscatter data in areas of potential U.S. Extended Continental Shelf (ECS). There is strong interest from NOAA in providing additional value-added utility to the ECS datasets by extracting further information from them that is useful to managers implementing ocean ecosystem-based management (EBM). The goal of this task is

to interpret the ECS data using novel classification approaches developed at the Center, in combination with existing ground-truth data, to gain insights into predicted substrate types of the seafloor and to characterize the geomorphic features of the seafloor consistent with the Coastal and Marine Ecological Classification Standard (CMECS). CMECS has been endorsed by the Federal Geographic Data Committee as a national standard, and thereby provides a

“common language” of marine habitat types across large regions and management jurisdictions. Translating bathymetry and backscatter data from ECS work into standardized classification maps provides enhanced utility of the information into a host of management, research, and ocean exploration applications. For instance, the Northeast Regional Ocean Council (NROC) has formally committed to using CMECS across state and federal ocean

management jurisdictions so that marine habitat data can be combined, analyzed, and used to support management decisions throughout the region. Translating raw ocean mapping datasets from the Atlantic Margin collected by NOAA OER and the Center into CMECS compliant maps and databases is therefore a priority to ensure the full realization of the value of these data to NOAA and the nation.

**Project: Standardized Geomorphic Classification of Seafloor Within the United States Atlantic Canyons and Potential Extended Continental Shelf Region**

**JHC Participants:** Derek Sowers, Jenn Dijkstra, Giuseppe Massetti, Larry Mayer, Andrew Armstrong, James Gardner, and Paul Johnson

**NOAA Participants:** Derek Sowers

Utilizing a bathymetric synthesis generated from all available high-quality data from the U.S. Atlantic Margin canyons and ECS region, this research effort generated broad scale geomorphology maps as a key component of marine habitat characterization in support of ecosystem-based management. This study utilized the automatic segmentation capabilities of BRESS to initially identify landform features from the bathymetry of the region, then used ArcGIS Pro to translate these results into complete coverage geomorphology maps of the region utilizing the Coastal and Marine Ecological Classification Standard (CMECS) to define landforms.

The resulting CMECS geoform classes indicated that abyssal flats make up more than half of the area (53%), with the continental slope flat class making up another 30% of the total area. Flats of any geoform class (including continental shelf flats and guyot flats) make up 83.06% of the study area. Slope classes make up a cumulative total of 13.26% of the study region (8.27% abyssal slopes, 3.73% continental slopes, 1.25% seamount slopes). While ridge features com-

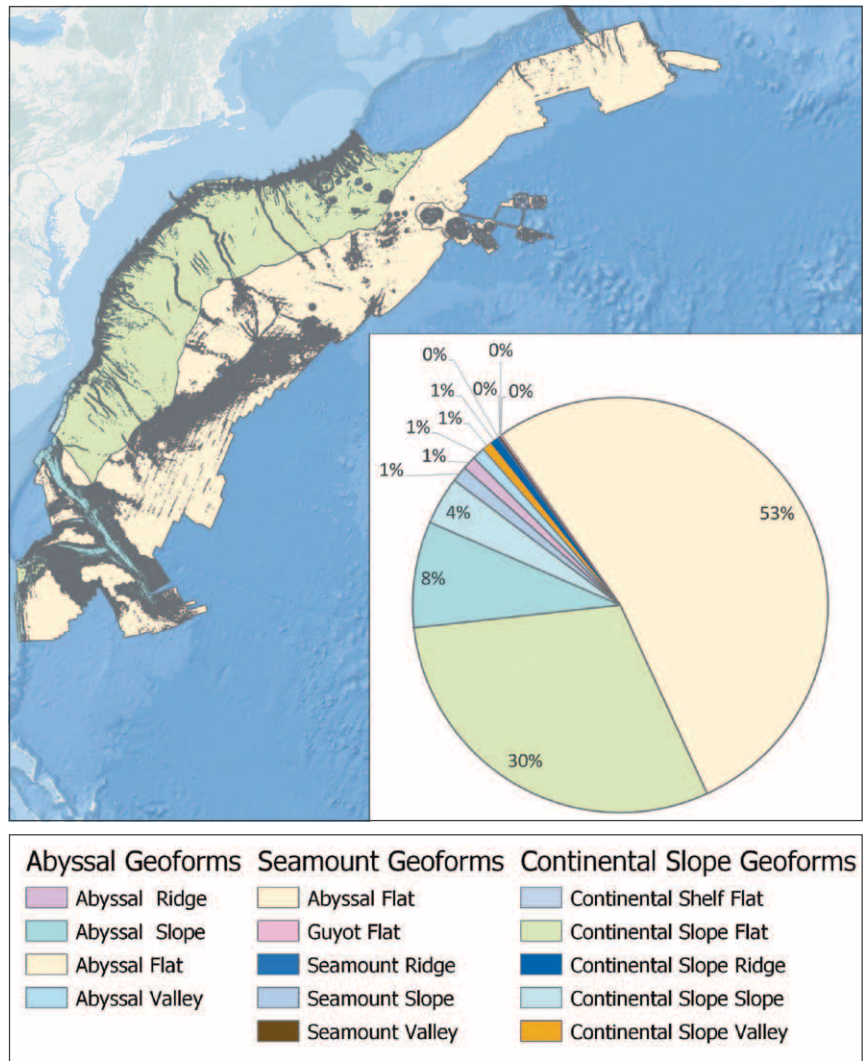

Figure 50-1. CMECS geomorphology classifications for the entire Atlantic Margin region in the study.



prise only 1.82% of the total study area (1.03% abyssal ridges, 0.63 continental slope ridge, and 0.16% seamount ridges). Figure 50-1 illustrates the results for all geoform classes across the entire Atlantic Margin study area. Figure 50-2 shows a zoomed-in view of the classification results in the vicinity of Blake Ridge.

Key benefits of the study's semi-automated approach included high speed classification of terrain over very large areas and complex terrain, reduced subjectivity of delineation relative to manual interpretation of landforms, transparency and reproducibility of the methods, and the ability to apply the same methods to large regions with consistent results. The ability to quickly automatically classify features such as steep slopes and ridges, generate accurate spatial datasets of these features, and calculate the area encompassed within them, should be of great interest to marine predictive habitat modelers. The derived maps and associated databases can be used for a broad range of spatial analyses defined by other end users to inform management decisions.

The approach developed through this work provides a model of how to consistently classify ecological marine units using CMECS as an organizing framework across large potential ECS regions nationally or globally. Given that many nations have already invested heavily in gathering bathymetric data for their potential ECS areas, this approach can easily be adopted to obtain a standardized interpretation to inform baseline marine habitat characterization in support of ecosystem-based management. These analyses represent a first

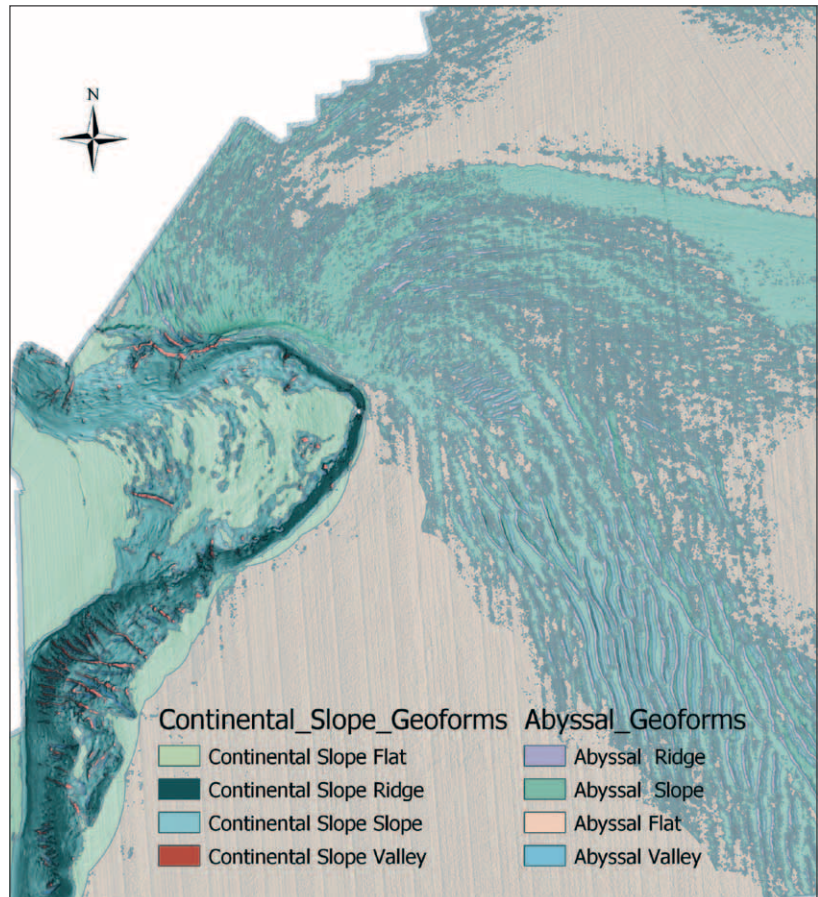

Figure 50-2. CMECS geoform classes for a portion of the study area highlighting Blake Escarpment, Blake Spur, and Blake Ridge. The figure provides mapped landforms in both the continental shelf and abyssal portions of the area. The massive bedform features in the right corner of the figure are striking, with crest-to-crest distances between 2000-3000 meters. The significant features of the terrain are well represented in the geoform unit polygons derived from the landforms generated via the automatic delineation algorithm in BRESS.

step in identifying regions of consistent morphology within which the consistency of the backscatter can then be determined. Detailed analysis of the backscatter response for insights into predicted substrate types within the Atlantic ECS region is planned for the next phase of the study.

### Project: Fine-Scale Mapping of Critical Marine Habitats in the Northeast Canyons and Seamounts

**JHC Participants:** Jenn Dijkstra, Larry Mayer, Kristen Mello, and Derek Sowers

**NOAA Participants:** Derek Sowers, Mashkoor Malik, and Elizabeth Lobecker

Previous reports utilized Gosnold Seamount as a preliminary study to determine the usefulness of a systematic framework for structuring geoform, substrate, and biotic classification of benthic habitats. Results of this study

indicated that this standard can provide a consistent and reproducible habitat classification approach for large regions and facilitate comparison of habitats among seafloor features such as canyons and

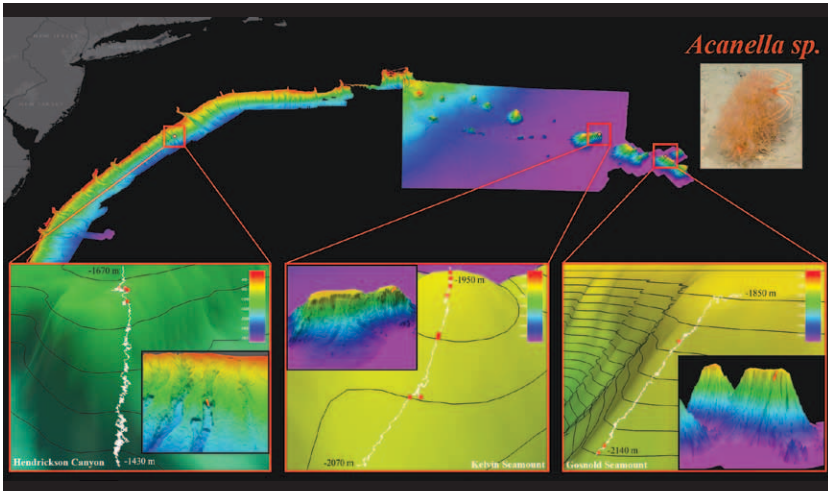

Figure 50-3. ROV tracks showing the distribution of bamboo corals collected in Hendrickson Canyon, Kelvin and Gosnold Seamounts.

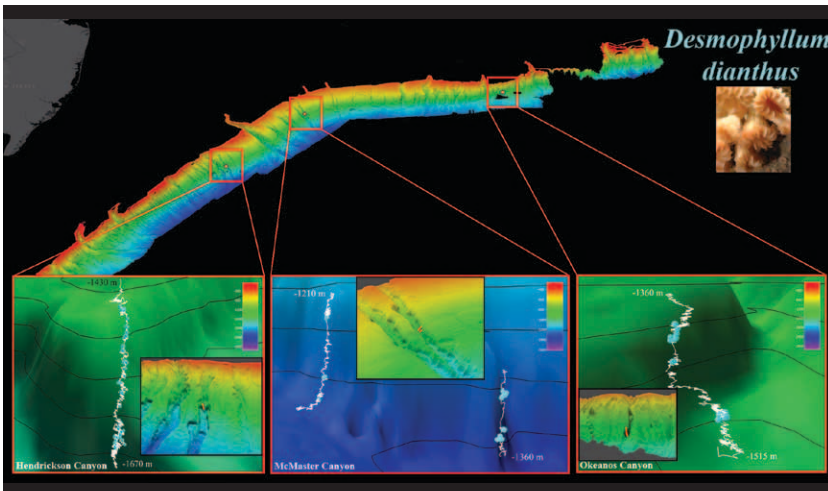

Figure 50-4. ROV tracks showing the clumped distribution of cup corals observed in Hendrickson, McMaster and Okeanos Canyons.

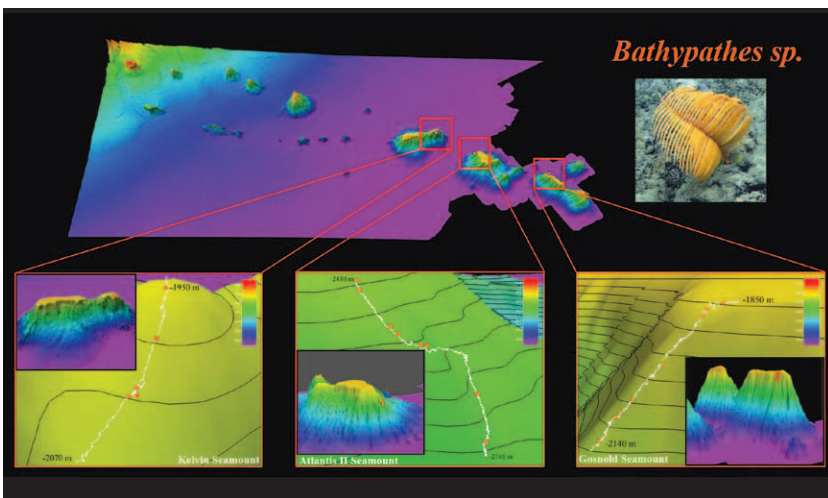

Figure 50-5. ROV tracks showing the wide distribution of black coral observed on Kelvin, Atlantis II, and Gosnold Seamounts.

seamounts (Sowers et al., in press). Substrate classes available in the standard worked well to characterize substrates observed in the ROV video data. A further result of this study clarified the need to analyze the full ROV track (i.e., those areas in which the lasers are off) for comparison with associated environmental data and geofoms.

As a first step towards a regional habitat classification, underwater video footage for 12 sites in the region were analyzed for taxonomic identity. Footage was collected by the NOAA OER team on September 28, 2014 using the fully integrated, dual-body ROV system, the Deep Discoverer (D2) and Seirios. For this progress reporting period, the project team finished analyzing the full ROV video collected at two seeps, five canyons, and five seamounts along the Northeastern Canyons and New England Seamount Chain. A customized ROV video analysis tool developed by the Center and OER was used to facilitate playback and integrate CTD data files (salinity, temperature, depth and dissolved oxygen), organism, slope (derived from the bathymetry), and sediment type. Sediment and taxonomic classification were determined manually along the ROV tracks by a trained researcher and integrated into a common annotation interface that used the shared time stamps associated with each dataset with navigation. Organisms were identified to the lowest possible taxon or morphotype using the recorded (auditory and written) events log captured for each dive. Identification of organisms were conservative given that identifications were made based on video imagery without the benefit of voucher specimens. Identifications ranged from species to family level. Organisms from the phylum Echinodermata and Sponges were identified to class. Sponges and corals that could not be identified to a lower taxonomic level were placed

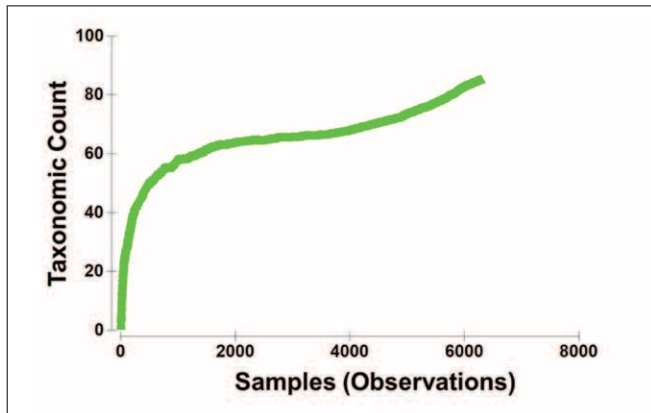

Figure 50-6. Species accumulation curve for taxa observed in the Northeast Canyons. Samples are the number of individuals observed in ROV video footage.

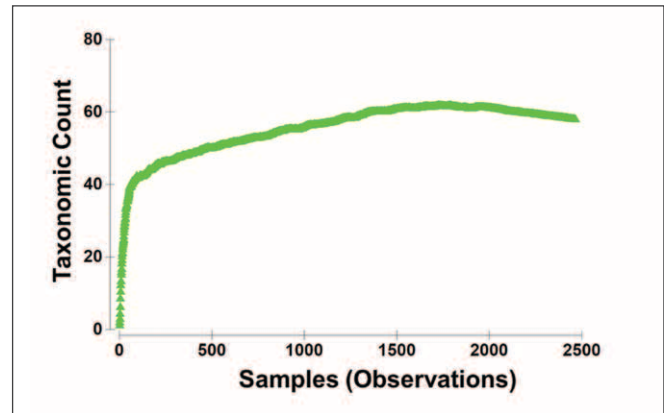

Figure 50-7. Species accumulation curve for taxa observed in the Northeast Canyons. Samples are the number of individuals observed in ROV video footage.

in subclasses. These data were then plotted, along with each taxa on the ROV track that overlays the bathymetry (Figure 50-3 through 50-5; examples of taxonomic distribution along an ROV track collected from three sites of occurrence). These novel tools and approaches were further refined by the OER team and are now implemented in Ocean Networks for analysis of NOAA Ship *Okeanos Explorer* ROV data. While this analysis can be time consuming, it provides a more refined taxonomic distribution map for fine-scale habitat mapping. Preliminary correlations of environmental parameters and occurrence of individual taxa have been performed with dissemination of these results underway. This study is ongoing with the intent to correlate landforms generated from the software package developed at the Center (Masseti et al. 2018) with species and biological communities as well as to physical and water column properties.

To determine if adequate sampling effort in canyons and seamounts captured species richness for these areas, a sample based non-parametric estimator, Chao2, was used to construct species accumulation

curves. Chao2 has been shown to remain precise even under changes in sampling effort and since ROV bottom time varies among sites, use of this statistic is appropriate for this study. Because an asymptoting accumulation curve indicates that the total species richness for a given area has been captured, species accumulation curves that converge on the same asymptote reflect adequate sampling effort. Preliminary results for Northeastern canyons show an asymptote around 2000 samples; as the number of samples increased, the curve also increases, suggesting inadequate sampling effort (Figure 50-6). Total number of samples observed on seamounts was <2500 (Figure 50-7). While the curve appears to asymptote, further sampling will likely result in an increasing curve, similar to canyons. Sampling at different depths and aspects of seamounts will add to the biodiversity observed in this region as different species are observed at different depths and aspects. Collections of individuals, not easily identifiable using imagery, is also critical to provide a complete species list for biodiversity assessments of this region and specifically the Northeast Canyons and Seamounts Marine National Monument.

### Project: Mapping of Physical and Biological Features at Dorado Outcrop, a Cool Vent Seamount

JHCParticipants: Anne Hartwell, Jenn Dijkstra, and Giuseppe Massetti

The goal of this project is to develop novel methods to analyze existing acoustic survey data using classification approaches developed at the Center, in combination with existing high resolution and fine-scale ground-truth data collected at Dorado Outcrop, 3100 meters deep and ~100 miles off Costa Rica. Dorado Outcrop was discovered as a site of low temperature (12°C) discharge on a ridge flank section of the Cocos plate where heat flow anomalies exist. There is extensive knowledge about microbes, subsurface geological processes, and geochemistry. In addition, high resolution bathymetry, backscatter, and imagery were collected on Dorado Outcrop in 2013 and 2014. A total of 22,489 images were collected by AUV Sentry (AT24-09), ROV Jason-II (AT24-09), and



HOV ALVIN (AT26-24). Bathymetry and backscatter were collected by Kongsberg EM122 (12kHz) on the R/V *Atlantis* and a RESON 7125 (400kHz) on AUV Sentry. These datasets have not been mined and can build on the rich datasets of previous studies to provide a comprehensive fine-scale habitat map. In this progress report, second year Ph.D. student, Anne Hartwell, has identified and counted macrofauna observed on Dorado Outcrop (Fig. 50-8). Further, she has developed a basic interactive aid to help users learn about the community at Dorado and has begun to explore segmentation methods and techniques of acoustic bathymetry and backscatter using Bathymetry- and Reflectivity Based Estimator for Seafloor Segmentation (BRESS; Masetti et al. 2018).

This study is ongoing with the intent to create a fine-scale habitat map of biological and physical factors and then use physical factors to create a predictive model of species and communities observed at Dorado Outcrop. Further, the community observed on Dorado will be compared to that of the Davidson Seamount in the NOAA Monterey Bay Sanctuary, whose physical properties are similar to

that of Dorado. As the community on Dorado Outcrop and Davidson Seamount likely reflects the community structure on many low temperature discharge locations in the deep sea, results of this study can be extrapolated to enhance predictive mapping capabilities of species and communities.

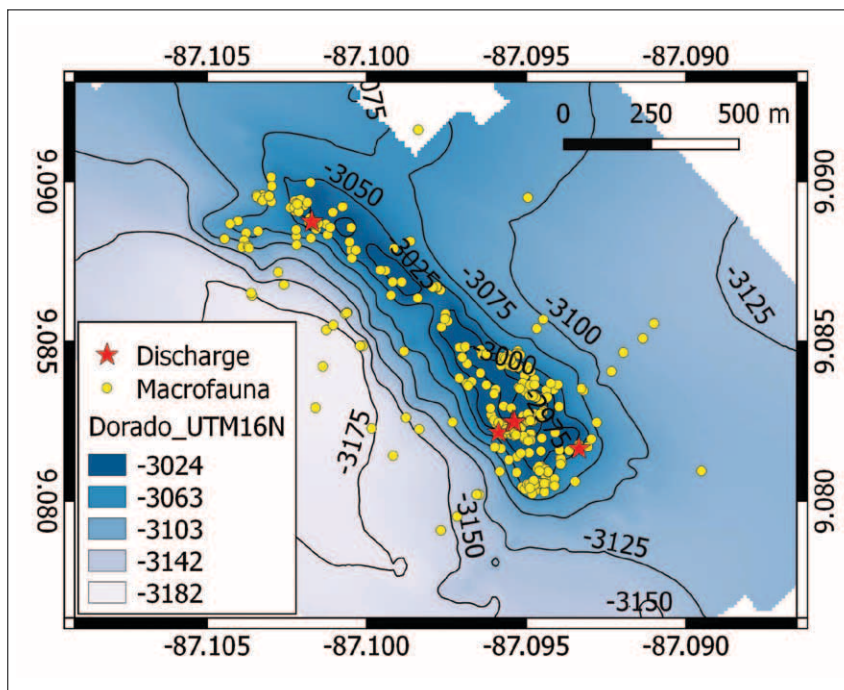

Figure 50-8. Map of Dorado Outcrop showing the distribution of macrofauna and sites of fluid discharge. Yellow circles show macrofauna distribution; Red stars show discharge distribution.

**TASK 51: Potential of MBES Data to Resolve Oceanographic Features:** Explore the possibility of mapping fine-scale structure in the water column with MBES and fisheries sonars. Work with our sonar manufacturer partners to see if certain data acquisition parameters can be optimized for revealing water mass structure and, in particular, evaluate the potential of broadband or multi-frequency data for these sorts of studies. **PIs: John Hughes Clarke, Larry Mayer, and Tom Weber**

**Project: Shallow Water Imaging of Internal Waves and Mixing—Impacts on Survey Quality**

**JHC Participants:** John Hughes Clarke and Shannon Hoy

**NOAA Participant:** Glen Rice

**Other Collaborators:** Rebecca Martinolich and Dave Fabre, NAVOCEANO; Vera Quinlan and Fabio Sacchetti, Marine Institute, Ireland; Ciaran O'Donnell, Fisheries and Ecosystems, Marine Institute, Ireland; Ian Church, OMG/UNB

**Additional Funding:** NAVOCEANO

While OCS's focus remains on nautical charting, the quality of their product is often hampered by the presence of rapid sound speed variability. Such variability is a result of rapid local changes in the oceanographic

environment, which are often characterized by variations in the daily or seasonal thermocline, resulting in internal waves and turbulence. This task addresses the potential to image these phenomena

in real time so that operational staff can adapt their surveys or sampling programs to minimize the impact. These oceanographic phenomena are also of high interest to NMFS as they often represent areas of enhanced biological activity.

In 2019, the two big advances were the routine application of the imaging approach to multi-spectral fisheries surveys, and the utilization of sonar mode with shallow water multibeam to image near surface oceanographic variability as part of deep water mapping exercises.

### Multi-Spectral Acoustic Delineation of Water Masses

As a follow on from the thesis of Jose Cordero Ros in 2018, the application of multi-spectral imagery using routine fisheries section was investigated. While the EK-60 experiments in 2017 was specifically undertaken from a hydrographic survey vessel, providing an indicator of the local conditions, far more extensive regional surveys are routinely undertaken by the Fisheries Division of the Irish Marine Institute. This is analogous to NMFS standard stock assessment surveys. The

R/V *Celtic Explorer* undertakes annual (since 1988) fish stock assessments surveys of Irish and European waters. This involves continuous profiling with EK-60 18-38-120-200 kHz systems, ground truthed with trawl and CTD observations.

As part of an expansion of the previous work, multi-spectral image sections across the Celtic Sea were produced and compared to CTD ground-truth. The results (Figure 51-1), clearly illustrate the strongly contrasting scattering characteristic of the water masses above and below the seasonal thermocline. The CTD data illustrate that the main scattering boundary seen is indeed that seasonal thermocline. What the imagery then provide is a means of spatially interpolating these sparse measurements to define shorter wavelength undulations in that boundary. Of particular note is the delineation of the regional structure of the thermocline which appears to be significantly tidally pumped. These images provide a means of planning hydrographic sound speed sampling strategies.

The EK-60 sections provide a regional overview but represent only a 2D along track section and are derived from a broad (seven

degree) beam system and thus have poor resolution of the shorter wavelength oceanographic structure. As part of the *Celtic Explorer* surveys, multi-spectral multibeam systems also operated along the same tracks and they notably have exhibited much better definition of the short wavelength mixing phenomena. Results were presented in the 2018 reporting period. There is however a notable frequency dependence on the definition of oceanographic boundaries. Figure 51-2 illustrates the difference for a specific region.

As with all acoustic volume scattering imagery, the source of the scattering patterns has many potential origins including

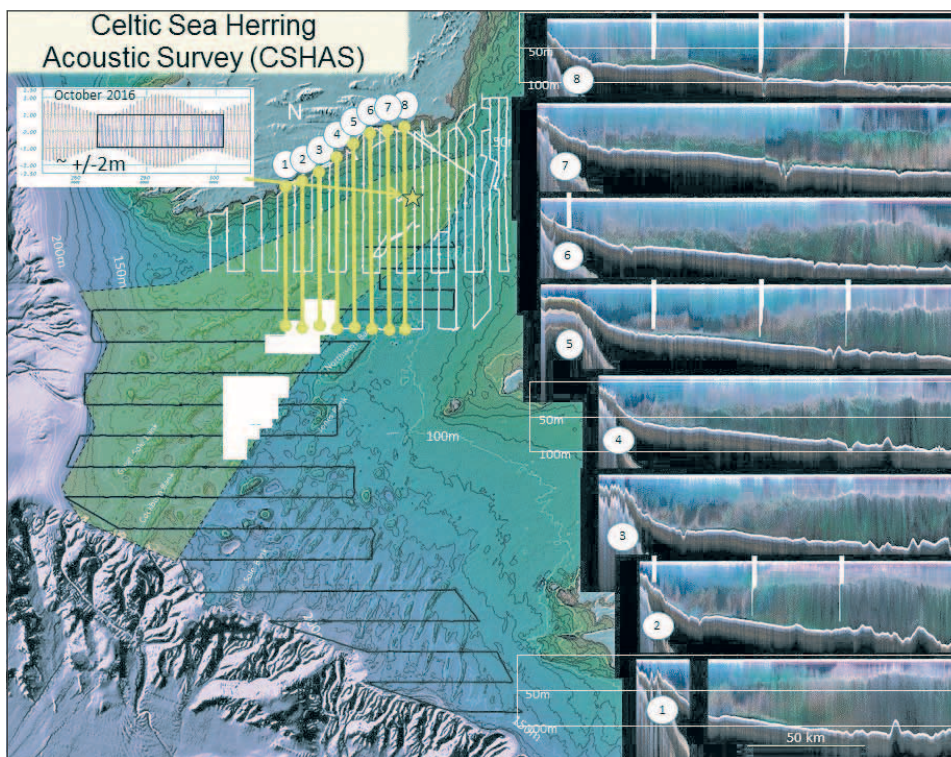

Figure 51-1. Triple Frequency (18-38-120 kHz R-G-B) acoustic imaging of water mass boundaries in the Northern Celtic Sea. Acquired as part of the Annual Herring Acoustic Surveys. Overlain profiles show the temperature structure derived from stationary CTD profiles.



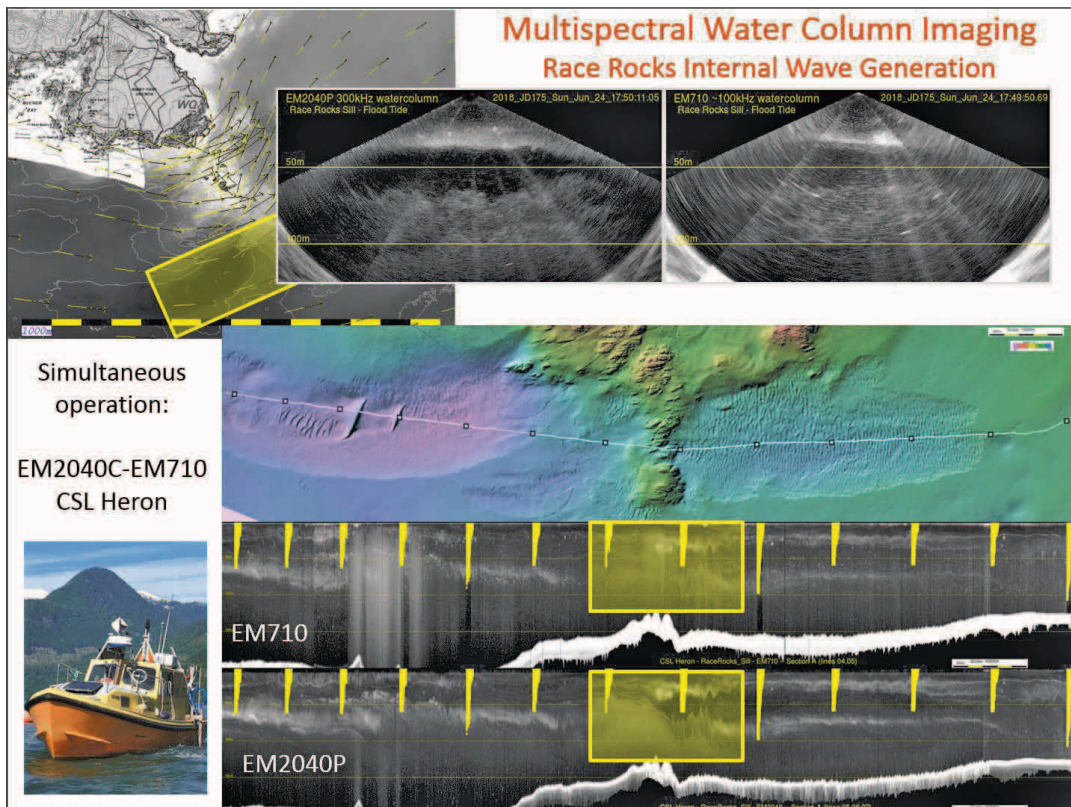

Figure 51-2. Simultaneous Dual Frequency multibeam Water column Backscatter Imaging of Internal Wave generation site – Race Rocks Sill, Strait of Jun do Fuca. Overlain are MVP temperature profiles illustrating the depth of the thermocline.

zooplankton, turbulence, bubbles, suspended sediment and well as contrasting oceanographic water masses. Ultimately there needs to be an element of ground-truth. Figure 51-2 illustrates the use of rapidly dipping MVP to determine the correlation between the image undulations and the main water mass boundaries. With training and familiarization, such scrolling displays would significantly aid the hydrographer in making near-real time decisions on the need to update sound speed measurements.

#### Utilization of Sonar Mode Imaging to Define the Near Surface Oceanography During Deep-Water Surveys

This approach was pioneered in 2016 on board the USNS Maury by Hughes Clarke. Deep water multibeam cannot define the near surface structure due to poor range resolution and the delays required to utilize multi-sector transmissions. To address this deficiency, the otherwise unutilized EM710 was used to image the upper 500m.

As a follow on to that experiment, Shannon Hoy recently acquired comparable data from the NOC vessel RRV *Discovery*. The EM710 was run in sonar mode with a 250m range for extensive transit surveys in the Labrador Sea (Figure 51-3). Further testing was undertaken on board USNS Bowditch in July involving simultaneous acquisition by both an EM2040 and an EM712 in sonar mode to look at differing depths within the upper ocean stratification. A notable additional use for such imagery includes detecting the presence and origin of bubble wash down. Examples are presented in the Task 7 reporting.

#### Summer Operations – 2019

As part of collaborative operations with the Ocean Mapping Group at UNB, the CSL Heron was again deployed to oceanographically active areas in British Columbia. Multi-frequency imaging (300 and 100 kHz) has been acquired of internal wave activity off Race Rocks (Figure 51-2) and sediment suspension over the Cordova Channel sand wave field.



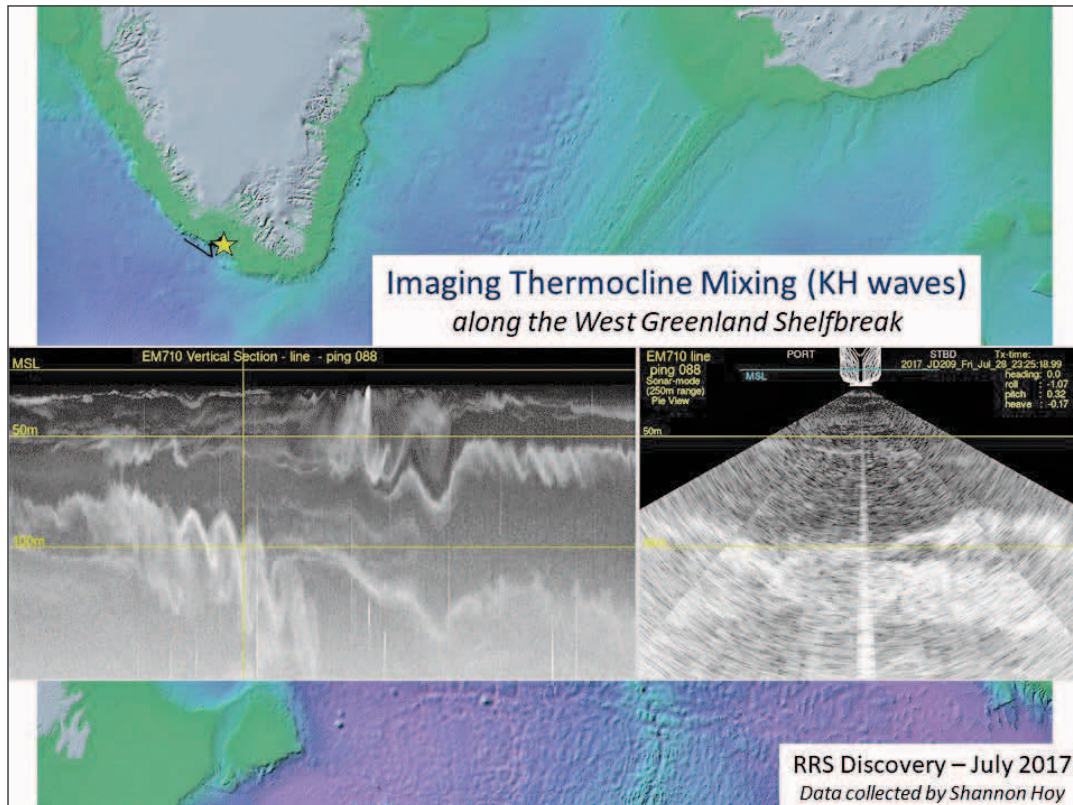

Figure 51-3. Sections of Kelvin Helmholtz waves developed in the thermocline, acquired using an EM710 in sonar mode (250m range) while operating an EM122 in slope depth water off the West Greenland Continental Shelf (RRV Discovery, acquisition by Shannon Hoy).

### Project: Imaging Oceanic Structure in Deep Water

**JHC Participants:** Larry Mayer, Tom Weber, Kevin Jerram, Elizabeth Weidner, and Erin Heffron.

**Other Participants:** Christian Stranne and Martin Jakobsson, University of Stockholm; Jon Cohen, University of Delaware

**Additional Funding:** NSF

Over the past few years, we have been able to demonstrate the ability of multibeam sonar and broadband echo sounders to image fine scale oceanographic structure. This work (mostly funded through U.S. National Science Foundation and Swedish grants) leverages our efforts to explore the limits of imaging the water column using the sonars we traditionally use for seafloor or fisheries mapping. Our Arctic efforts were focused on understanding the interaction between relatively warm Atlantic-sourced water and colder Arctic waters in the Arctic Ocean and the implications these interactions have on the stability of sea ice. This kind of mixing often results in the formation of thermohaline staircases. Staircase structures in

the Arctic Ocean have been previously identified by CTD and the associated double-diffusive convection has been suggested to influence the Arctic Ocean in general and the fate of the Arctic sea ice cover in particular. A central challenge to understanding the role of double-diffusive convection in vertical heat transport is one of observation. We were able to use both broadband single beam (EK80) and multibeam (EM122) echo sounders to unequivocally demonstrate that thermohaline staircases (and by extension other similarly sharp gradients in ocean temperature and salinity) can be acoustically mapped over large distances (hundreds of kilometers) in the deep ocean (Figure 51-4).

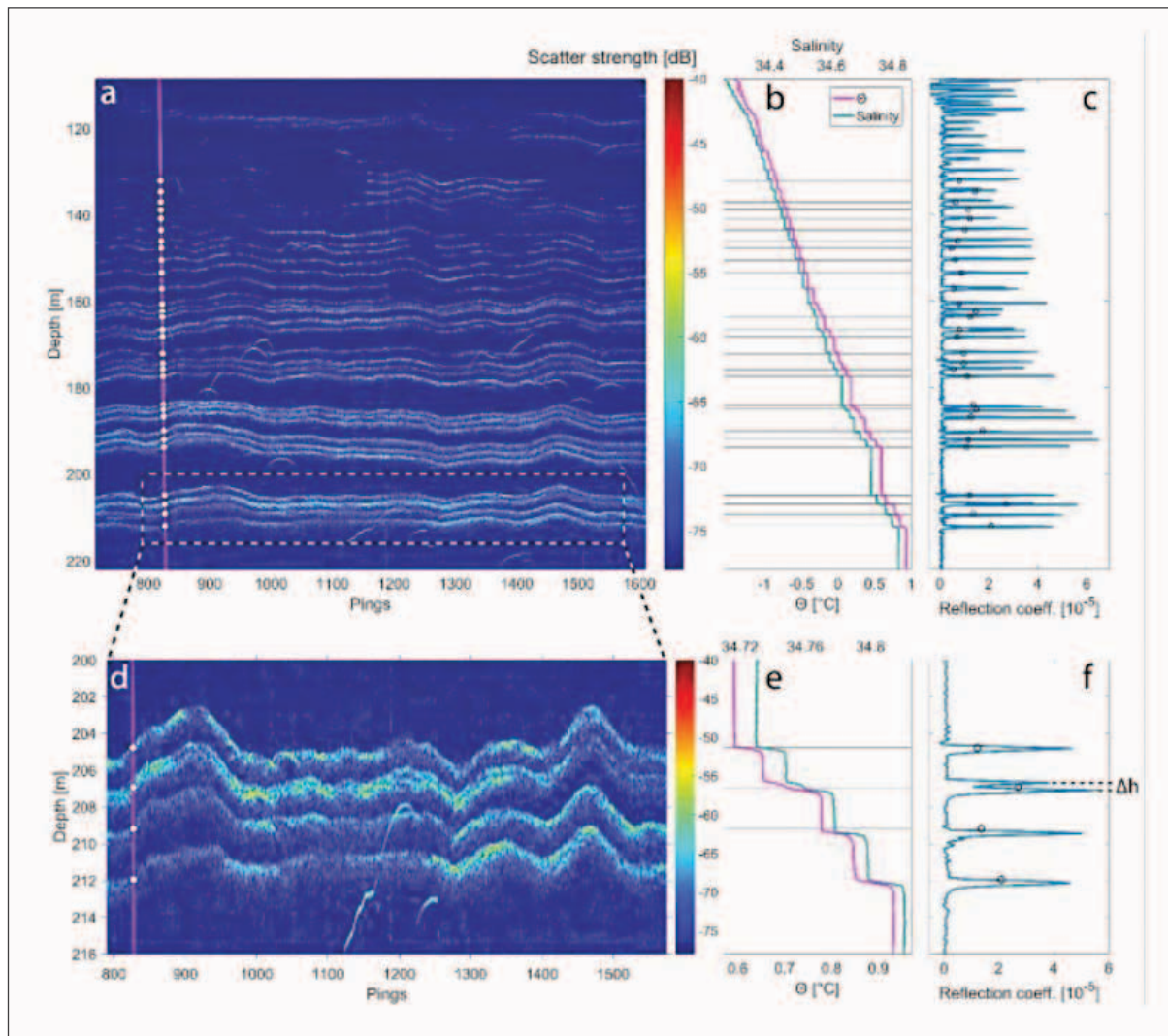

Figure 51-4. Acoustic observations of a thermohaline staircase. a, Processed EK-80 echogram with 8 ms pulse length covering 2.5 hr and a distance of 7 km, with CTD cast (magenta line) and layer depths derived from the echogram scatter strength (white circles). b, CTD potential temperature with reference at the surface ( $\Theta$ ) and salinity profiles with black horizontal lines indicating the depth of the individual layers identified in the echogram (white circles in a). c, reflection coefficient derived from CTD salinity and temperature profiles (blue line) and reflection coefficients estimated from the calibrated target strength in each layer (black circles) at depths derived from the echogram (white circles in a). d-f, same as a-c but over the narrower depth range indicated in the dashed box in a.  $\Delta h$  ( $= 0.4\text{m}$ ) in f is the distance between two reflection coefficient peaks, partly visible in d, and represents the minimum spacing visually separable between acoustic horizons (observed vertical resolution). Echoes from fish are seen throughout the data (a,d) as irregular, sometimes hyperbolic, traces.

The growing evidence that we can acoustically image the fine-scale thermohaline structure of the water column not only has ramifications for our understanding of physical oceanography but offers new approaches for us to understand the sound speed structure of the water column and how it impacts sea floor mapping. The results of the Arctic work have recently been published in *Nature Scientific Reports*.

As reported in previous years our work has also demonstrated the ability to use broadband EK80s to trace the mixed layer depth over hundreds of kilometers and to map what appear to be regions of varying water mass properties in Arctic fjords. In 2019, Elizabeth Weidner demonstrated another oceanographic application of broadband EK80s, the ability to map the anoxic zone in the Baltic Sea.

## Project: Baltic Sea Broadband Oxidic-Anoxic Interface Investigation and Mapping

**JHC Participants:** Elizabeth Weidner, Tom Weber, and Larry Mayer

**Other Participants:** Christian Stranne and Martin Jakobsson

Another opportunity to analyze unique water column data came through Elizabeth Weidner's participation in a cruise investigating Baltic Sea hypoxia on the R/V *Electra*, with researchers from Stockholm University and Swedish University of Agricultural Sciences. The low oxygen (hypoxic) zone in the Baltic Sea is a result of poor circulation and eutrophication from anthropogenic nutrient fluxes and occurs in deep, stagnant waters. The preliminary goal of the cruise was to investigate how oxygen deficiency in the water column affects pelagic fish behavior.

*Electra's* broadband split-beam echo sounders, the ES70 and the ES200, were run continuously during all four days of survey operations, in addition to the collection of 20 CTD profiles. During survey operations it became apparent that there was a continuous acoustic scattering layer at approximately 60 m depth (Figure 51-5), that appeared to roughly correspond to the onset of reduced oxygen in the water column as measured from the CTD casts.

The high signal to noise ratio and vertical range resolution of the broadband systems allows for identification of weakly scattering phenomenon in the water column. In the Baltic Sea the interface between the shallow, surface oxygenated waters and the deep anoxic zone is defined by an increase in density (pycnocline) resulting from the transition between the cold, fresher, oxygenated water of the surface to the warmer, saltier, anoxic waters at depth. The preliminary goal of this research was to determine if the observed scattering layer corresponded to a specific oxygen level, for example the point of minimum oxygen. The secondary goal was to determine the nature of the scattering mechanism at this layer

(e.g., density contrast, biological scattering, turbulence) and the extent of the layer depth across the survey area; as this could provide insight into processes that affect the depth and extent of the anoxic zone in the Baltic and by extension, the pelagic fish species in the region.

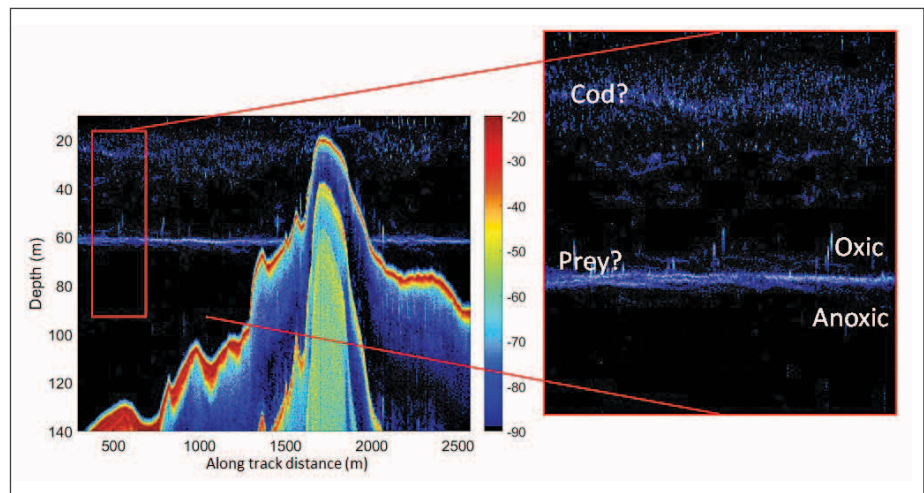

Figure 51-5. Preliminary EK80 echogram from EL18-B5. The scattering layer at the top of the hypoxic region is visible at approximately 60 meters depth.

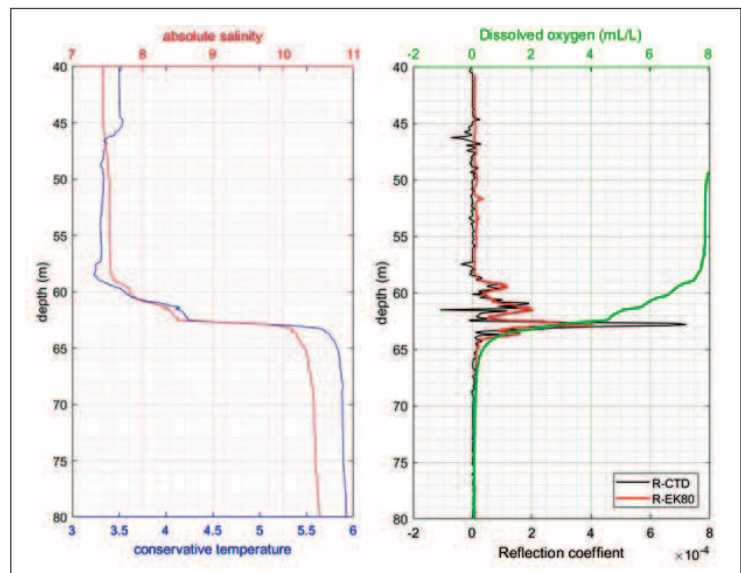

Figure 51-6. Example reflection coefficient comparison at CTD location 1. The black reflection coefficient profile corresponds to the CTD estimate and the red to the acoustic estimate.



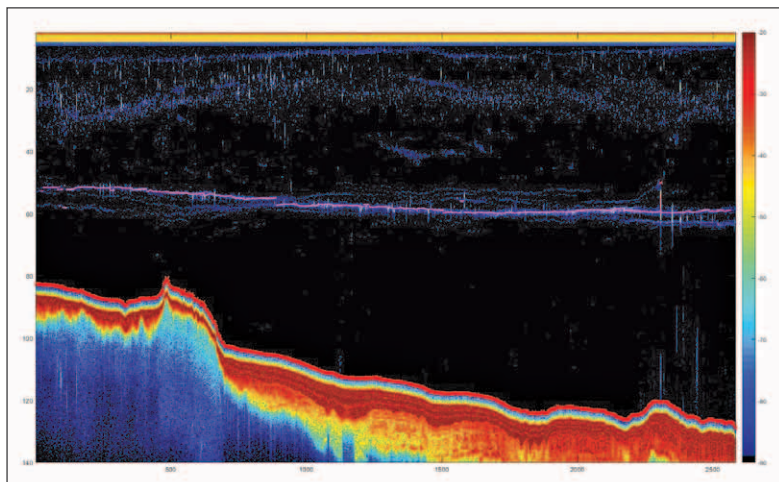

Figure 51-7. An example echogram of the tracked oxygen minimum location over a transect in the Baltic.

We can directly measure the target strength (TS) of a layer after applying the calibration offset, correcting for spherical spreading and absorption, as well as applying a draft offset (for direct comparison against the CTD profiles). Scattering from fish in the layer of interest was masked based on a coherency factor computed from the individual quadrants of the split-beam system; fish aggregations should scatter incoherently if discrete within the beam (unless exactly at nadir) and any scattering layer will be coherent across all quadrants, as it extends beyond the beam. After masking fish scatterers, the reflection coefficient of the acoustic datasets leading up to the CTD profile locations was computed as the average of 31 pings to account for variability.

The resulting reflection coefficients from the acoustic dataset were plotted against estimated reflection coefficients from the CTD profiles, as well as the oxygen, temperature, and salinity profiles (Figure 51-6).

The resulting dataset shows that in the position in the watercolumn of the peak acoustic reflection coefficient and the peak CTD reflection coefficient are within 0.9 meters with one standard deviation of 2.0 meters of each other (Table 1). All further uncertainty statements here represent standard deviation estimates. The magnitude of the peak reflection coefficient derived from the acoustic data verse CTD data are comparable, within an order of magnitude (Table 2). Z-scores for all but two of the stations (13 and 15) fall within one standard deviation. We believe these results suggest scattering seen at the interface can be explained the physical changes in the water properties (as opposed to biology or some other mechanism).

Even more significant, the depth of the peak acoustic reflection coefficient corresponds to the depth of the hypoxic point of 2 ml/L dissolved oxygen (1.1 meter +/- 0.62 meters) (Table 3). These results suggest that the position of the hypoxic zone, the beginning of the oxygen minimum zone, can be successfully tracked within approximately 1 meter by determining the position of the peak reflection coefficient in the acoustic data. Moreover, by utilizing the CTD locations as a means of ground truth for the acoustic data, the remote "tracking" of the oxygen minimum location can be verified at certain locations to determine if the tracking algorithm is successful.

The oxygen minimum "tracking algorithm" was applied to the entire acoustic dataset, resulting in an estimated depth of the anoxic zone across the region of the Baltic Sea where the survey operations took place (Figures 51-7 and 51-8).

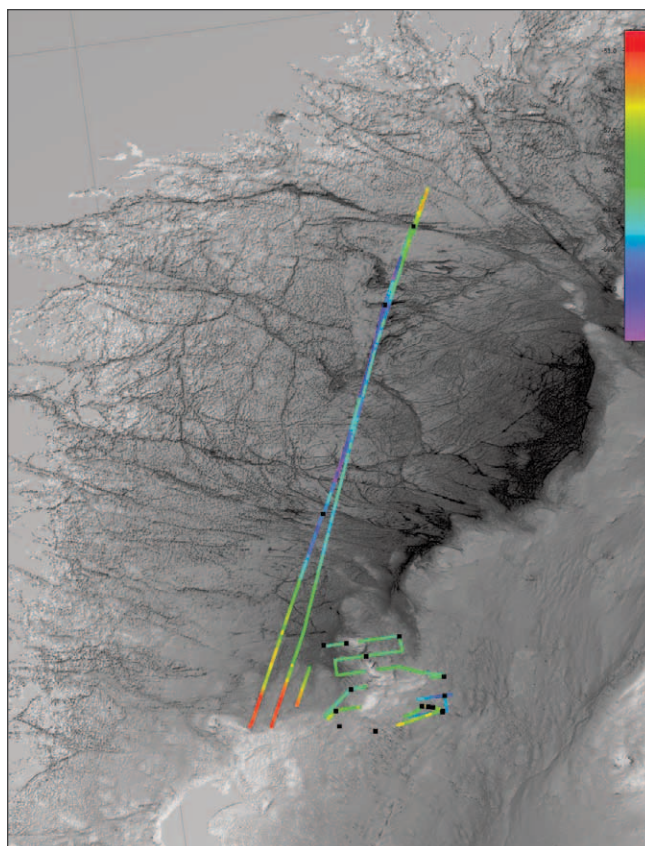

Figure 51-8. Overview of the oxygen minimum depth across the entire survey area, as computed from the acoustic peak reflection coefficient.

## Research Requirement 3.C: Telepresence and ROVS

**FFO Requirement 3.C:** “Improvements in technology for integration of ocean mapping with other deep ocean and littoral zone technologies such as remotely operated vehicles and telepresence-enhanced exploration missions at sea.”

**TASK 52: Immersive Live Views from ROV Feeds:** *Develop an immersive telepresence system that combines the multiple data streams available from live ROV missions (e.g., video, bathymetry, etc.) with models of the ROV itself into a single 3-D environment. Continue to explore and enhance the use of telepresence to provide shipboard support for mapping systems. Pls: Tom Butkiewicz, Roland Arsenault, and Vis Lab*

### Project: Realtime and Post-Mission 3-D Interactive Display of ROV data

JHC Participants: Tom Butkiewicz

Current practice for ROV telepresence is very similar to mission-playback and dive videos, in that the general experience is simply watching video footage, live or recorded. This has the significant disadvantage of being limited to viewing only from the first-person perspective of the video camera(s), and for mission-playback, having to watch in linear-time. However, by using the video and other data sources, we can construct 3D scenes that are freely-explorable and can be viewed from any angle. For example, a telepresence viewer might be better able to help guide an ROV's robotic arm if they viewed the ROV from a side position rather than from the camera's position.

These scenes can be constructed using several data sources: we can use Structure from Motion (SfM) to calculate photo-textured 3D models from the videos. However, SfM reconstructions can take days to process, making them only appropriate for mission-playback. A more exciting possibility is creating a 3D scene around the ROV in real time using new 3D imaging sonar technology, such as the Coda Octopus Echoscope.

To this end, Butkiewicz worked with industrial partner Coda Octopus to get their Echoscope data output in a format that contained enough supplemental information that it could be used to construct per-frame 3D triangle mesh surfaces suitable for projecting camera data onto and necessary to support live interactive viewing from arbitrary angles. Butkiewicz has been adapting his algorithms that were previously developed at the Center for use with Microsoft Kinect depth cameras to perform real-time transformation of the Echoscope data from Coda Octopus's Real-Time XYZ Module to 3D surface visualizations in our immersive VR interface.

Butkiewicz had previously developed a Unity Engine-based dive mission playback tool, deployable on multiple VR platforms, which provided a proof-of-concept freely-explorable SfM recreation of a coral reef from single-camera (GoPro) dive footage. An updated version has been developed that supports newer VR hardware, displays higher-fidelity coral reef models, and provides interactive tools for taking 3D measurements, performing spatial analysis, and tagging species. This interface can be seen in Figure 52-1.

Using that updated project's code as a base, a new ROV playback and live telepresence interface is being developed. Butkiewicz has been collecting data with the aim to recreate the May 2019 E/V *Nautilus* and ROV Hercules mission at Osborn Bank in the Channel Islands off Southern California. This mission is a particularly interesting candidate for an immersive ROV telepresence proof-of-concept because it involves exploring caves using the Echoscope 3D imaging sonar.

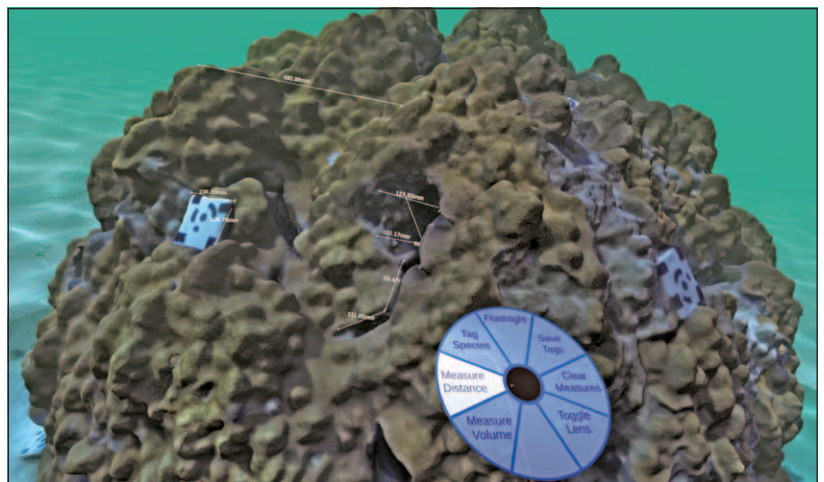

Figure 52-1. Screenshot from the updated CoralVis VR software, showing a high-fidelity coral model (generated by Jordan Pierce and Jennifer Dijkstra) and 3D measurements (white lines/text) made using tools accessed via the radial-menu (blue disc) attached to the handheld controller. This interface is also used in the ROV telepresence/playback application.

## Programmatic Priority 4: Hydrographic Expertise

### Research Requirement 4.A: Education

**FFO Requirement 4.A:** “Development, maintenance, and delivery of advanced curricula and short courses in hydrographic and ocean mapping science and engineering at the graduate education level—leveraging to the maximum extent the proposed research program, and interacting with national and international professional bodies—to bring the latest innovations and standards into the graduate educational experience for both full-time education and continuing professional development.”

**TASK 53: Upgrade of Education Program and Update Ocean Mapping Curriculum: Modify courses and labs as needed. Develop short courses in collaboration with NOAA and others. Pls: John Hughes Clarke, Semme Dijkstra, and Center Faculty**

**Project: Curriculum Upgrades and Development**

**JHC Participants:** Brian Calder, John Hughes Clarke, Semme Dijkstra, Larry Mayer, Larry Ward, Rochelle Wigley, Giuseppe Masetti, and Juliet Kinney

**NOAA Collaborators:** Andy Armstrong

The content, sequence and delivery of the ocean mapping training at the Center is continuously being updated to represent current developments and feedback from NOAA and our students. Careful attention is also paid to ensure that the FIG/IHO/ICA Category A course standards are continued to be met. In the past year the following upgrades to the curriculum have been made:

#### Adoption of Python as the Preferred Programming Language

In November 2018, after discussions with NOAA OCS, the Center decided to switch from MATLAB to Python as the preferred programming language for the ocean mapping courses. Among many reasons for this switch, a few stand out: Python is freely available to students before, during, and after their tenure at the Center; Coast Survey manages and uses Pydro—a suite of software tools mainly implemented in Python—at many steps of the data acquisition and processing workflows; and, Python is increasingly popular within the scientific community. Our students are still free to use a programming language of their choice but can expect better support when using Python. NOAA staff seconded at UNH will now also be able to obtain essential programming skills in the Python language.

#### E-Learning Python for Ocean Mapping

Students at the Center need to have a minimum level of programming skills to successfully complete many of their assignments. Historically, a significant amount of time was required to teach the students the programming skills required. Thus, the decision to create e-learning courses to ensure a minimum

common level of programming skills among the incoming students. Since there is also a larger need to provide common programming skills for the hydrographic community, the e-learning courses were made openly accessible.

During the current reporting period, a committee (consisting of Semme Dijkstra, Giuseppe Masetti, and Rochelle Wigley) was created to propose an implementation plan. The committee identified two main lines of action that triggered the creation of two sets of teaching modules. The first of these sets of modules is *Programming Basics with Python* and was developed with the intention to be delivered to incoming students before their arrival at the Center. The second set of modules is *Introduction to Ocean Data Science*. It was developed with the intention to be delivered in person to the students (although they are also available online).

The committee decided to deliver the materials in the form of “Jupyter Notebooks.” These are documents that contain both Python code and markup text. This allows for the creation of a document with explanatory text and figures, working code examples and code-cells in which the students can enter their own code (Figure 53-1).



The students are not expected to have any familiarity with programming before commencing the ePOM sets of modules. Through the notebooks provided in each, the students will acquire the basic coding skills required to successfully complete the first assignments.

The overall task is to lead the students through some basic concepts of programming using the Python language, with a focus on their application to the Ocean Mapping field.

The main teaching goals are:

- Provide students with sufficient basic Python skills to successfully complete lab assignments. (Thus, not a full course on how to program in Python.)
- Familiarize the students with several programming concepts.
- Introduce the students to using the extensive help and resources available for Python.
- Provide the students with programming habits and skills that are directly applicable to other programming environments despite differences in syntax.

Two Center servers were assigned to host the *Programming Basics with Python* and *Foundations of Ocean Mapping Data Science* sets of modules using JupyterHub. JupyterHub provides a Python environment that runs on a multi-user server. Thus, this provides the students with a common learning environment that does not require the installation of additional Python libraries. Students need only access to an internet connection and a modern web browser.

*Programming Basics with Python* focuses on basic programming concepts with a focus on ocean mapping applications (Figure 53-2). For incoming students there are two phases: an initial phase of asynchronous online learning through a set of Jupyter notebooks, followed by a period during the student orientation in which the faculty can: answer student questions, evaluate the students' understanding of the concepts and, encourage collaboration among the students.

*Introduction to Ocean Data Science* acts as a connector to the 'Ocean Mapping option' core courses and consists of four modules that are taught by Masetti as part of the *Tools for Ocean Mapping Course* (Figure 53-3).

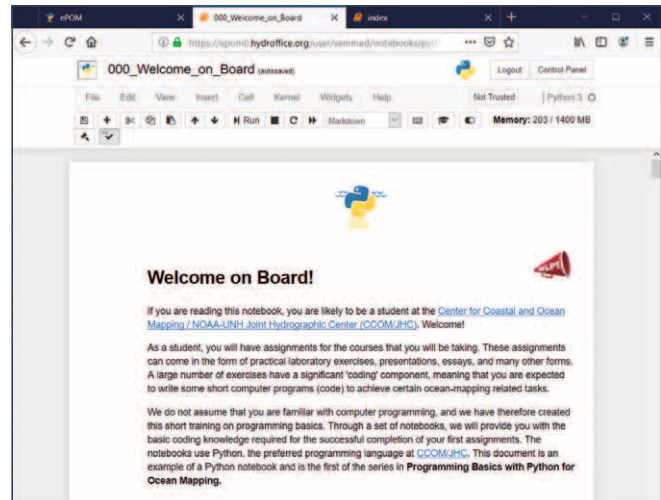

Figure 53-1. The ePOM welcome notebook.

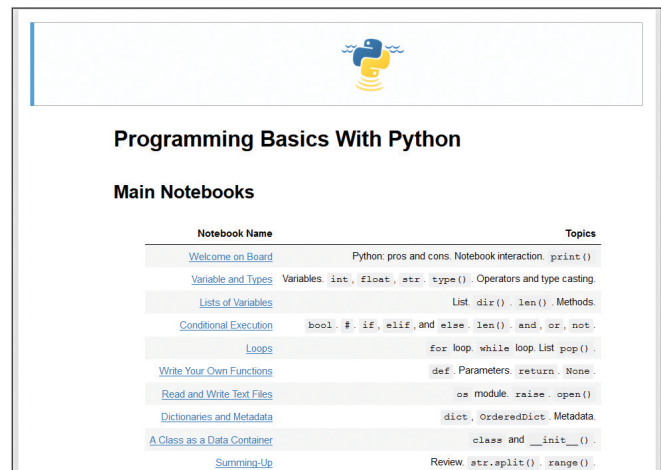

Figure 53-2. The Programming Basics with Python set of modules consists of ten Jupyter Notebooks.

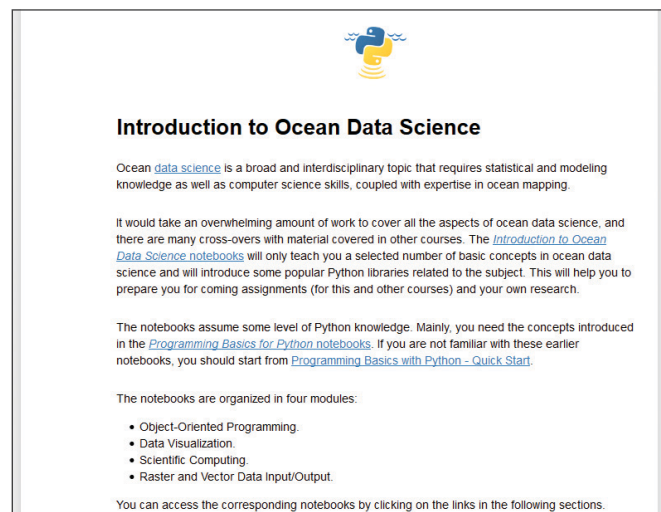

Figure 53-3. Introduction to Ocean Data Science is organized in four modules.

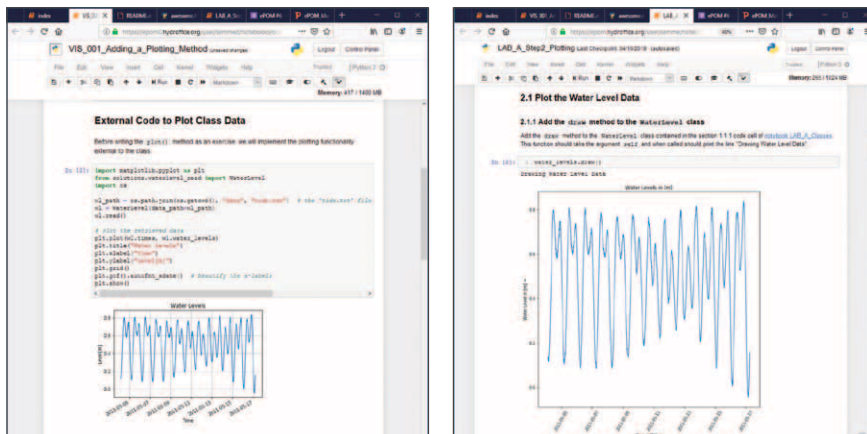

Figure 53-4. The Foundation of Ocean Mapping Science Notebooks (left) are in direct preparation to some of the assignments in the Center’s Integrated Seabed Mapping Course’ (right).

In the first two modules, taught in the first two weeks of the fall semester, material directly related to the lab work in the *Integrated Seabed Mapping Systems* and Geodesy and Positioning for Ocean Mapping courses is presented (Figure 54-4). These modules focus on data analysis and visualization (through the use of, e.g., *numpy* and *matplotlib* third party libraries), algorithms and data formats (e.g., *scipy*, *GDAL*, *CartoPy*).

In the third and fourth modules, presented in the last two weeks of the semester, focus is put on the development of research code, preparing the students for

more independent programming tasks. Students are introduced to a version control system (*git*), Integrated Development Environments (IDE) and *Pydro*.

Beta testing of *Programming Basics with Python* by 10 volunteers was completed. The volunteers were asked to rate their general impression of each notebook on a 1-10 scale, rate the relevance of the various sections in each Notebook, estimate the time that it will take to complete the notebook without a programming background and, finally, to sug-

gest changes or provide additional comments (Figure 53-5). The feedback was overwhelmingly positive, the materials provided were rated as highly relevant and the provided time estimates suggest that incoming students should have no problem completing the Notebooks in timely matter. The Notebooks were updated at the hand of the comments and suggested changes wherever needed.

Development on the Notebooks for both *Programming Basics with Python* and *Introduction to Ocean Data Science* has been completed and are available

online. Both sets of notebooks have been made available in *Pydro* with the assistance of Tyanne Faulks (NOAA PHB) and Barry Gallagher (NOAA HSTB). Accounts have been created for incoming students as well as other interested parties, including NOAA personnel.

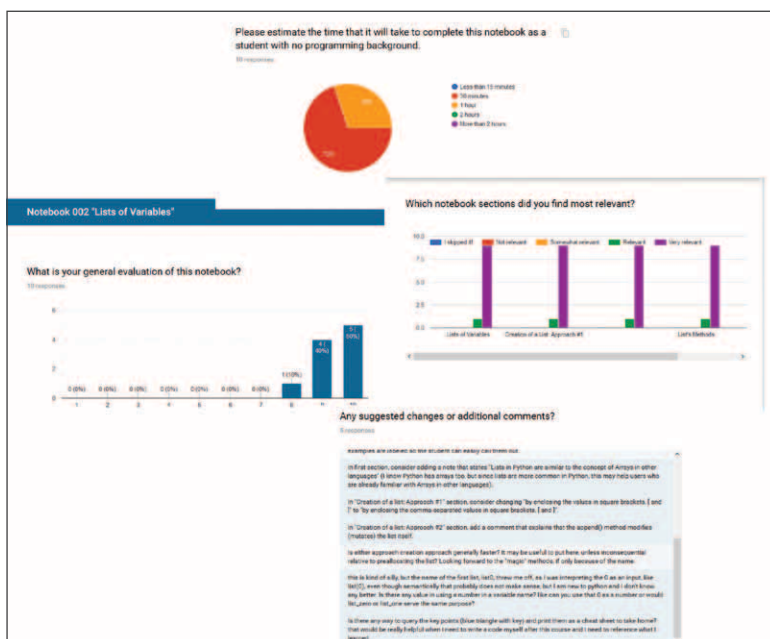

Figure 53-5. Example feedback from *Programming Basics with Python* beta testing.

## Course: Integrated Seabed Mapping Systems

In 2018, the integrated Seabed Mapping class was offered for a third time with some minor alteration based on student feedback. Hughes Clarke teaches the majority of the course, with significant contributions by Dijkstra (field and lab exercises and motion sensors) and Calder (digital filtering). New for 2018 was the addition of Graduate Teaching Assistant (GTA) Brandon Maingot. In preparation for the fall of 2019, Dijkstra has completed the first assignments implemented in *Python Notebooks* (Figure 53-6).

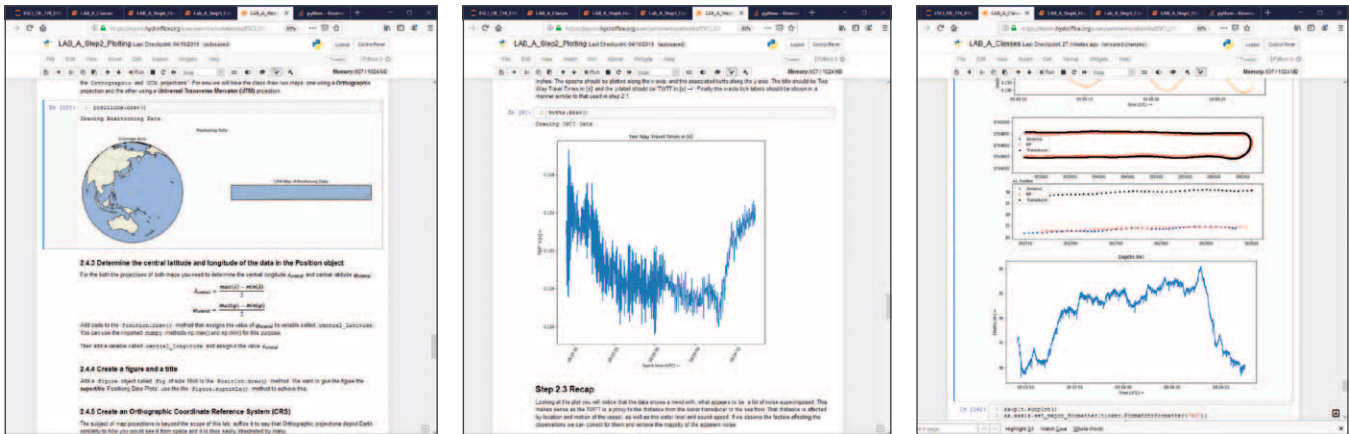

Figure 53-6. In the first assignment, implemented through a set of Python Notebooks, students are presented with data collected in the West Pacific (left), they proceed by integrating the raw echosounder observables (middle) with the positioning, motion and tide data to derive georeferenced depth data (right).

**Course: Fundamentals of Ocean Mapping-II**

This course was renamed “Advanced Topics in Ocean Mapping” in 2019 to better represent its place within the curriculum. Dijkstra teaches the majority of the course, with significant contributions by Armstrong (Tides) and Mayer (Seafloor Characterization).

**Changes to the Marine Geology/Geophysics Curriculum**

**Course: Marine Geology and Geophysics for Hydrographic Surveyors**

Marine Geology and Geophysics for Hydrographic Surveyors was taught for the second time with some minor alteration based on student feedback. The two-credit hour course was taught by Larry Ward, John Hughes Clarke, and Rochelle Wigley.

**Course: Oceanography for Hydrography**

In January 2019, the oceanography course was presented for the third time. The course contents and presentation were left unchanged after a positive reception by the students of the first courses. The course was taught by Hughes Clarke in the J-term in January 2019.

**Course: Geodesy & Positioning for Ocean Mapping**

In 2019, new course notes reflecting ongoing technological development in GNSS positioning were added, with a focus on precise point positioning and baseline differencing techniques. Due to the computational nature of the course, Dijkstra has begun to implement all materials and labs in Python Notebooks (Figure 53-7) to allow embedding live examples of coordinate transformations, least square adjustments, Kalman filtering, etc. Presenting the course materials in Python Notebooks significantly reduces the gap in the theoretical presentation of the materials in class and their practical application in labs.

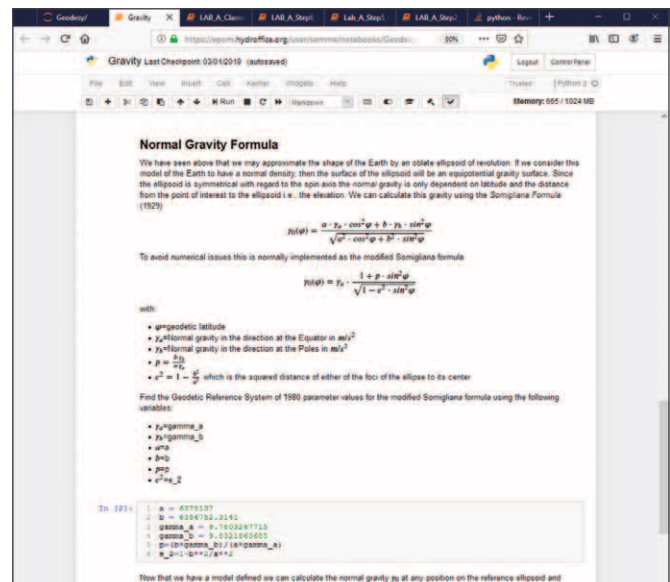

Figure 53-7. Course materials are being implemented in Python Notebooks, allowing the presentation of theoretical concepts together with live examples of their use. In the snippet of the Notebook on Gravity shown here the ‘modified Somigliana formula’ is presented, along with Python code implementing it.



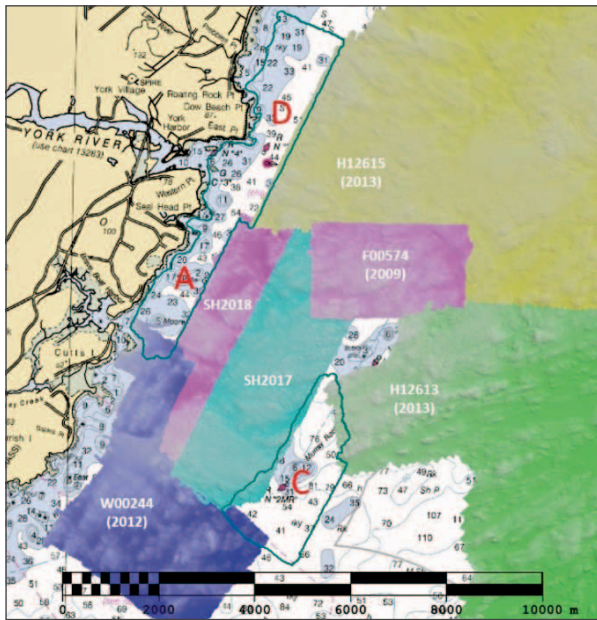

Figure 53-8. Survey area relative to pre-existing coverage. The majority of the area was last surveyed before 1950.

## Hydrographic Surveying Field Course

This year the course commenced with a week of QPS software training, followed by a week of CARIS training. The practical work consisted of a week of planning activities, five mobilization days, three weeks of data acquisition on R/V *Gulf Surveyor* and two weeks of reporting. In addition, there was a day each assigned for the installation of a tide gauge and tying it in to benchmarks, a gauge to staff comparison, the installation of a GNSS base station, and a coast line survey using aerial imagery obtained with a drone. In comparison to previous years this represents a shift in focus from planning to reporting as student feedback indicated that this would significantly improve the course.

All students were assigned management responsibilities and also were directed to submit activity reports based on an outline of all tasks to be fulfilled. The students were presented with a set of rubrics allowing them to better evaluate how well they performed to the expectation of the instructor (Dijkstra). This allowed for better communication with the instructor.

In recent years two parallel data acquisition streams were used with great success: one stream for routine data collection that will be processed and submitted to NOAA OCS and a second on which the students are allowed to alter the system settings and configurations allowing them to evaluate the impact of these on the collected data. This year the intention was to use an R2Sonic 2026 as the primary swath sonar

system, and an Edgetech 6205 as the secondary system. However, significant cross talk between the systems made operating simultaneously impossible, thus the decision was made to add two field days dedicated to altering system settings and configuration while surveying.

The 2019 Summer Hydrographic Field Course brought the R/V *Gulf Surveyor*, nine Center students, and several technical staff under the supervision of Semme Dijkstra to the near shore waters of York, ME. The primary objective was to finish the mapping of an area near York, ME that is currently not covered by any high-density survey technique (Figure 53-8).

Each student was involved in the planning of the survey, execution of the survey, processing of the collected data, and report writing. Activities included, among others, the creation of a budget, planning of patch tests, shore lining, data QA/QC procedures (cross line analysis, junctioning surveys), installation and verification of a tide gauge, the verification of the operation of a GNSS RTK base station, and the execution of an aerial beach shoreline survey using a drone.

A total of 141 nautical miles of main scheme lines were collected, with an additional 14 miles of cross lines in water depths ranging from 20 m to 40 m below MLLW for a total areal coverage of 14 km<sup>2</sup>. Additionally, 14 video stations were occupied at 10 of which grab samples were recovered. Finally, 0.4 km<sup>2</sup> of shoreline was mapped in high resolution using a drone (Figure 53-9).

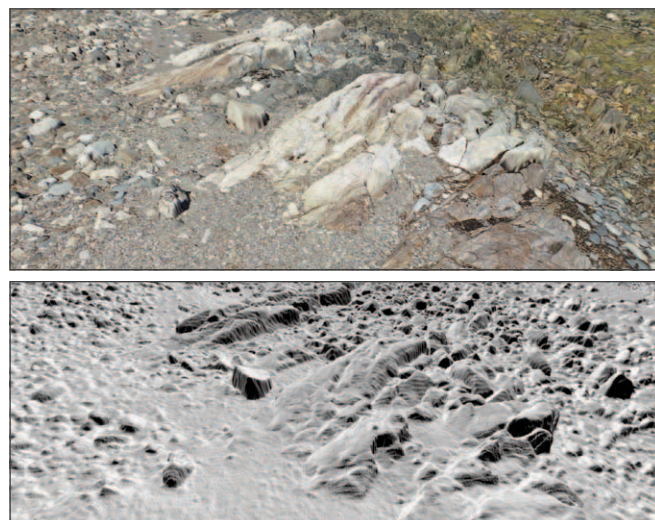

Figure 53-9. Digital Elevation Model (DEM) derived from Structure from Motion analysis of imagery obtained using a drone. The top image is the DEM overlaid with a photomosaic of the area, whereas the bottom is a sun illuminated grey scale representation of the DEM. Many of the observed features have spatial scales of just a few centimeters.

Routine data acquisition was performed using QPS QINSy collecting sonar data from an R2Sonic 2026 multibeam with sound speed profiles being provided by an AML MVP 30. The data were processed using, CARIS, FMGT, and POSPac. A comparison with Charts 13274, 13278 and 13282 was performed and in many locations observed depths were shallower than the charted depths (Figure 53-10).

Additional data was collected using an Edgetech 6205 PDES system mounted on the side of the *Gulf Surveyor*. Due to the fact that we could not place a motion sensor in its immediate vicinity and the primary motion being located at the end of another mount, we will not submit this data to NOAA OCS (unless requested) as there is too much decoupling of the motion at the transducer location from the IMU location.

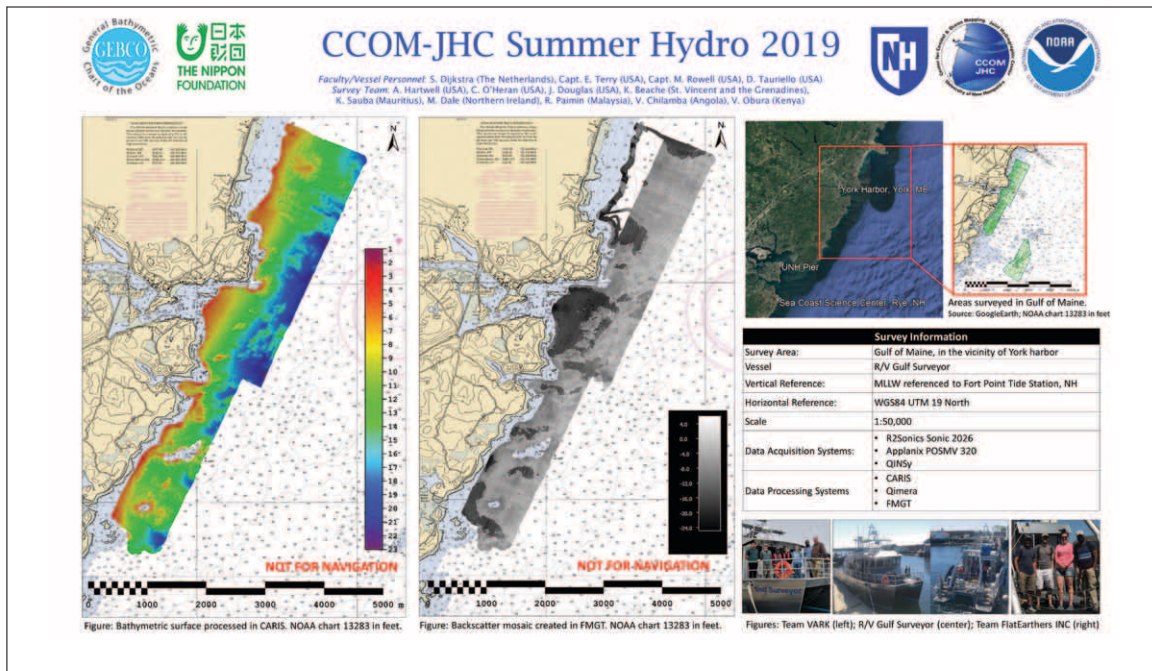

Figure 53-10 Poster representing the priority survey area near Gerrish Island, Maine.

**Submission of Data**

The data collected in the field courses are being submitted to NOAA's Office of Coast Survey for application to the charts. Juliet Kinney is integrating multiple different student group reports for each year into single submissions. As part of this effort, Kinney is organizing files produced by each course as part of the submission and performing quality assessment and control (QA/QC). Part of the QA/QC is to verify completeness of the data, and correctness of the Descriptive Reports (DR) and Data Acquisition and Processing Reports (DAPRs). As part of the QA/QC, an evaluation of data quality made; QCTools (see

Task 15) is run to double check for fliers to ensure the appropriate adjustments are made to make the reports in alignment with OCS Reporting Standards. This includes stripping the student submitted reports of any content not relevant to OCS.

Survey	Status	Estimated Completion
Summer Hydro 2019	Submitted Nov 2019	Submitted Under PHB Review
Summer Hydro 2018	Under Review	January 2020
Summer Hydro 2017	Ready to Submit	End of 2019
Summer Hydro 2016	QC Nearing Completion	End of 2019
Summer Hydro 2015	Light QC/Copying	End of 2019
Summer Hydro 2014	Copying/Double check	End of 2019
Summer Hydro 2013	Copying/Double check	End of 2019

Table 53-1. Progress of data submissions.



**Project: GEBCO Training Program**

**JHC Participants:** Rochelle Wigley, Larry Mayer, and other JHC Faculty

**Other Collaborators:** Shin Tani and Robin Falconer, GEBCO-Nippon Foundation

The Center was selected to host the Nippon Foundation/GEBCO Bathymetric Training Program in 2004 through an international competition that included leading hydrographic education centers around the world. UNH was awarded \$0.6 M from the General Bathymetric Chart of the Oceans (GEBCO) to create and host a one-year graduate level training program for seven international students. Fifty-seven students from thirty-two nations applied and, in just four months (through the tremendous cooperation of the UNH Graduate School and the Office of International Students and Scholars), seven students were selected, admitted, received visas and began their studies. This first class of seven students graduated (receiving a "Graduate Certificate in Ocean Mapping") in 2005. Fifteen classes, with ninety scholars from 40 coastal states, have since completed the Graduate Certificate in Ocean Mapping from the University of New Hampshire.

Funding for the 15th and 16th year of this Nippon Foundation/GEBCO training program was received from the Nippon Foundation in 2018 and the selec-

tion process for the 16th class followed the guidelines of including input from the home organizations of prospective students as well as including input from alumni on applicants from their home countries. The 2019 class of six were selected from 122 applications from 37 countries, attesting to the on-going demand for this course. The current 16th class of 2019/2020 includes students from Brazil, Greece, Jamaica, Japan, Mexico and the Republic of Kiribati—adding three new coastal states to the alumni network so that we will have 96 students from 43 coastal states (Figure 53-11).

The Nippon Foundation GEBCO students have added a tremendous dynamic to the Center both academically and culturally. Funding from the Nippon Foundation has allowed us to add Rochelle Wigley to our faculty in the position of Program Director for the Nippon Foundation/GEBCO training program. The six Year 14 Nippon Foundation/GEBCO Training Program students finished their academic year by participating, along with international cartographers and hydrographers from six other countries, in the

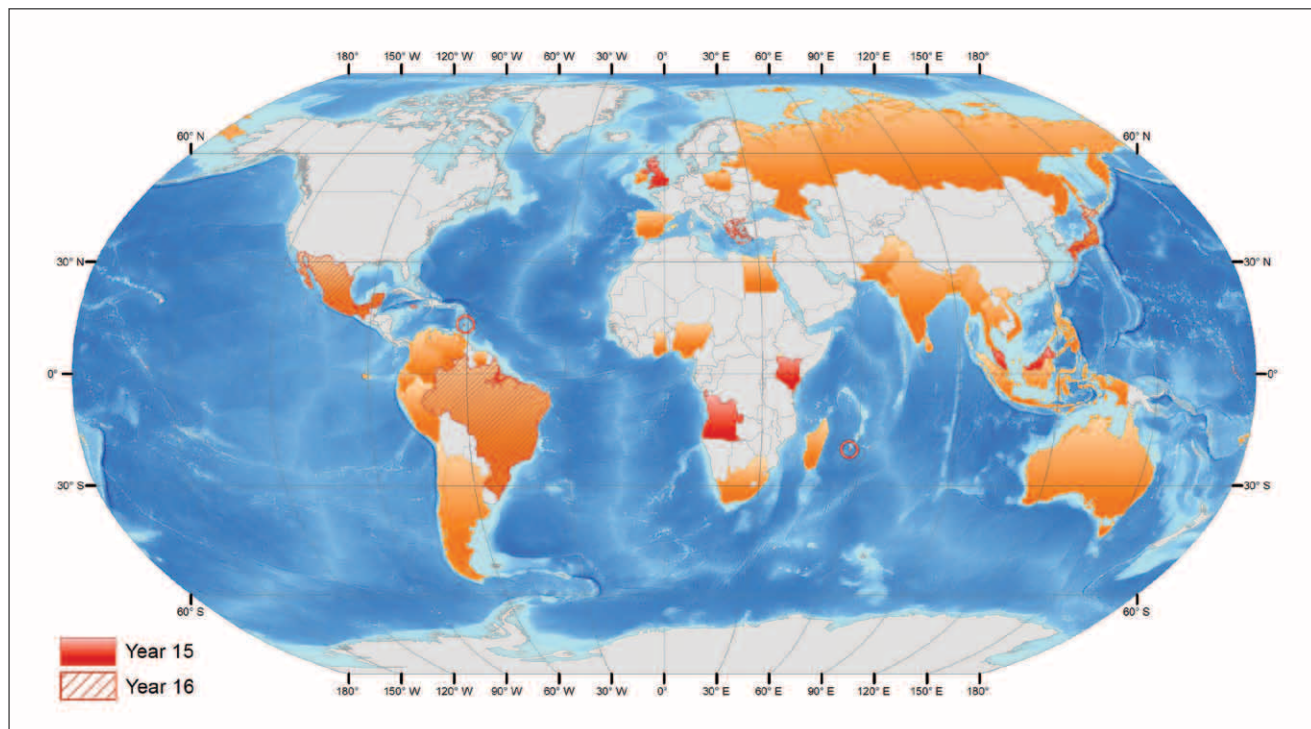

Figure 53-11. Distribution of the Nippon Foundation / GEBCO training program alumni (orange) with the Year 15 class in red and the current Year 16 class shown with a hatched symbol.





Figure 53-12. NOAA's 5th Nautical Chart Adequacy Workshop 2018 participants, representing 12 countries, and their instructors.

Fifth NOAA Chart Adequacy Workshop from 23-25 July 2019, and the Third NOAA Nautical Cartography Open House (27 July) hosted by NOAA's Office of Coast Survey (Figure 53-12).

Participants in the Nautical Chart Adequacy Workshop learned techniques to evaluate the suitability of nautical chart products using chart quality information and publicly available information. The hands-on GIS layer development and analysis demonstrated that the procedure is a low-cost tool that can help any hydrographic office assess the adequacy of its charts. Cecilia Cortina Guzman (Year 14) presented a poster on the "GEBSCO and NOAA Chart Adequacy Workshop" at the 29th International Cartographic Conference 2019 (ICC 2019) from 15–20 July 2019 in Tokyo, Japan. Haruka Ogawa of Year 14 was also in attendance.

The one-day Nautical Cartography Open House event focused on nauti-

cal cartography, highlighting the field of charting and GIS. It offered nautical cartography-themed posters, presentations, tours, and exhibits and allowed attendees to network with industry partners, government agencies, and charting offices from around the world. The six participants from the Hydrographic community included: Bruno Correia de Freitas Cardoso (Denmark), Sophie Loyer and Clément Gallic (France), Kazufumi Matsumoto (Japan), Felipe Ortiz Soto (Mexico), Fatui Abolarinwa Lasisi (Nigeria), and Prasit Chantorn (Thailand).

In addition to onsite training, the Year 15 Nippon Foundation/GEBSCO class attended an intense one-day training session at NOAA's National Centers for Environmental Information (NCEI) and co-located International Hydrographic Organization Data Center for Digital Bathymetry (IHO-DCDB) in Boulder, CO on 29 July. During this visit the students were introduced to the Marine Geology and Geophysics

Division research team and the projects being undertaken in terms of data management and stewardship (Figure 53-13).

The Year 15 scholars undertook lab visits at the end of the academic year:

**Mekalya Dale** sailed on the DSSV *Pressure Drop* for a Five Deeps transit from St. John's, Newfoundland to Svalbad from 8-20 August. Data was collected



Figure 53-13. Nippon Foundation/GEBSCO students during NCEI visit.

and processed on the transit leg to be included into Seabed 2030 compilation, with seven alumni and students from six years of the Nippon Foundation/GEBCO training program being involved in both transit and dive legs. Funding for this came from the John Hall fund at the Center and from Nippon Foundation funds related to student lab visits. Mekayla then worked with Tinah Martin and Dr. Vicki Ferrini at the Atlantic and Indian Oceans Regional Data Center for Seabed 2030 project that is hosted at the Lamont Doherty Earth Observatory (LDEO), Columbia University, USA, from September 23–October 11. The objective of this lab visit was to familiarize herself the Seabed 2030 workflow and the software that the data center is using. Keshav Sauba also spent a week with the Seabed 2030 group to strengthen the relationship of Mauritius with this relevant data center.

**Victoria Obura** undertook training at the Yeosu Academy Law of the Sea Training for her lab visit from 24 August to 10 September 2019 for the Yeosu 6th Session that had 47 participants from 29 countries. Coincidentally, Siong Hui Lim (Stanley from Year 9) was also a participant. The Yeosu Academy offers a two-week program for government officials, researchers, and other professionals engaging in ocean policymaking, as well as professors or graduate students who are interested in ocean affairs from developing countries. The course helps students understand modern law of the sea and critical international and regional ocean-related issues. The training helped her to better understand the underlying issues on the maritime boundary dispute between Kenya and Somalia and the dispute over Migingo Island between Kenya and Uganda.

**Victor Chilamba** visited the Directorate of Hydrography and Navigation of the Brazilian Navy (DHN) in Rio de Janeiro, Brazil from 2-23 August 2019. He spent a week each with the Hydrographic Surveys Analysis Division, the Nautical Cartography Division and the Research Vessels, Training Center and Aid to Navigation Division in order to understand their workflow from data collection to ENC production.

**Kemron Beache** used his lab visit to work on his Fundamentals of Engineering (FE) exam as the first step in the process to becoming a professional licensed engineer (P.E.) through the National Council of Examiners for Engineering and Surveying.

**Rafeq Paimin** spent three weeks from 26 August to 13 September at the South and West Pacific Ocean regional data center hosted at the National Institute

of Water and Atmospheric Research (NIWA), New Zealand working with Evgenia Bazhenova (Year 12 alumni) and Geoffroy Lamarche. The goal of this lab visit was to strengthen the relationship between the National Hydrographic Centre of the Royal Malaysian Navy and their relevant Seabed 2030 regional data center.

Two of the students, **Victoria Obura** and **Rafeq Paimin**, had the opportunity to sail onboard the *E/V Nautilus*, but unfortunately were not able to due to new visa requirements.

The Indian Ocean Bathymetric Compilation (IOBC) project is ongoing with the establishment of a database comprised of >700 available single beam, >95 multibeam data and a number of compilation grids. This project has proved to be an excellent working case study for the Nippon Foundation/GEBCO students to understand the complexities of downloading and working with publicly-available bathymetric datasets. The first IOBC grid has been included in the latest global GEBCO grid. The IOBC is now working closely with the Nippon Foundation–GEBCO Seabed 2030 Atlantic and Indian Oceans Regional Data Assembly and Coordination Center and will continue to develop this relationship to ensure that alumni are integral to the Seabed 2030 project.

One outcome of the Nippon Foundation/GEBCO Forum for Future Ocean Floor Mapping held from 14-17 June 2016 in Monaco, was the establishment of the GEBCO-NF Alumni Team for the Shell Ocean Discovery XPRIZE (Figure 53-14). The core GEBCO-NF Team is made up of fifteen alumni from of the Nippon Foundation/GEBCO Training Program and is being advised and mentored by selected GEBCO and industry experts (see <http://gebco-nf.com/>). The core group of 15 alumni represent 12 coastal states.

The GEBCO-NF Alumni Team was selected in February 2017 as one of up to 21 teams that would compete in October/November 2017 Round 1 field tests of the \$7 million Shell Ocean Discovery XPRIZE competition. The Nippon Foundation (and Sasakawa Peace Foundation) agreed to provide the GEBCO-NF Alumni Team more than \$3 million to assist concept development and the design of the new technology to be utilized in the semi-finals. The Shell Ocean Discovery XPRIZE Technology Readiness Tests then took place in Horten Norway in the week 20-23 November 2017, when the team entry was evaluated during a four-day XPRIZE Site Visit.





Figure 53-14. The GEBCO-Nippon Foundation Alumni Team.

On February 20, 2018, the GEBCO-NF Alumni Team was informed by XPRIZE that it had qualified to become a Finalist Team and would be eligible to test in Round 2 of the challenge. This milestone award

came with \$111,111.11 prize money. A BBC news release (amongst others) on 7 March 2018 informed the world that only nine other Teams had qualified for Round 2—see [www.bbc.com/news/science-environment-43317417](http://www.bbc.com/news/science-environment-43317417).



Figure 53-15. Mr Unno (Executive Director) and Mao Hasebe (Project Coordinator for the Ocean and Maritime Program and Strategy Team) of the Nippon Foundation with the GEBCO-Nippon Foundation Alumni Team members including Bjørn Jalving and Stian Michael Kristoffersen (Kongsberg Maritime) after the award ceremony in Monaco.

Nine teams were eligible to compete in the final round field tests. The GEBCO-Nippon Foundation Alumni team was the first team to undertake their field tests from 4-14 November 2019. The team successfully proved their original auto-nomous (and unmanned) concept, achieving their goal of mapping >250 km<sup>2</sup> during the allotted 24 hours and produced a final bathymetric surface of 278.9 km<sup>2</sup> that was a fusion of the USV- and AUV-mounted multibeam (EM304 and EM2040 respectively), HISAS real-aperture bathymetry, and synthetic-aperture bathymetry.





Figure 53-16. The GEBCO-NF Alumni Team concept for the Shell Ocean Discovery XPRIZE competition and the main industry partnerships established by the Team shown.

Four teams subsequently withdrew and the team was therefore one of only five teams to undertake the final sea trials.

The GEBCO-Nippon Foundation Alumni Team was revealed as the \$4 million grand prize winner at the awards ceremony hosted at the world-renowned Oceanographic Museum of Monaco, part of the Oceanographic Institute, Prince Albert I of Monaco Foundation on 31 May 2019. The award money will be given to the Nippon Foundation to be used for furthering the goals of the Nippon Foundation-GEBCO Seabed 2030 project and building on the skills of the GEBCO-NF Alumni (Figure 53-15). This grand prize award was broadly published in the media. See:

- <https://www.bbc.com/news/science-environment-48473701>
- <https://www.unh.edu/unhtoday/2019/06/unh-alumni-team-wins-xprize>

One of the grand challenges of our times is to map our sea floor. This is being addressed by Seabed 2030—a Nippon Foundation-GEBCO partnership. Seabed 2030 proposes that mapping the oceans will only be done through international and multi-disciplinary collaborations with people working together and sharing data. The GEBCO-NF Alumni Team’s winning effort for the Shell Ocean Discovery XPRIZE clearly demonstrated that these concepts are viable and that they can lead to success. The international multidisciplinary team of 78 people from 22 countries, which combined commercial and research objectives, worked closely together to achieve their objective of creating a new mapping system in a remarkably short time period. The XPRIZE submission also fulfilled two of the Seabed 2030

pillars through capacity-building and new unmanned and autonomous technology development. The Team’s proposed solution leveraged existing state-of-the-art ocean floor mapping technology with new innovations in offshore logistics, backed by industry leading companies, to collect high-resolution bathymetric data through autonomous means (Figure 53-16).



Figure 53-17. Mr Unno, Masanao Sumiyoshi, Sattiabaruth Seeboruth, Prime Minister Shinzo Abe, Mr Sasakaw, Rochelle Wigley, Karolina Zwolak and Hisataka Hiragochi (Director General of National Ocean Policy Secretariat) during September visit to Prime Minister’s office.



Figure 53-18. Nippon Foundation/GEBCO Training Program alumni present at GEBCO meeting in Portsmouth in November.

The GEBCO-Nippon Foundation Alumni Team used their success to promote the Nippon Foundation/GEBCO Training Program and their winning approach. The team was unique in its diversity of nationalities, education, culture, age, gender, and color. Their backgrounds and careers represented academia, industry, national governments, and non-profit corporations from around the world. This diversity was their strength. The team presented at least 11 posters/presentations at international conferences in 2019.

Four team members also had the opportunity to meet Japanese Prime Minister Shinzo Abe on 18 September 2019 to talk about the technology they developed and how their model of international scientific cooperation can help to map the gaps that still exist in our understanding of the ocean floor. Also present were Yohei Sasakawa, the Chairman of The Nippon Foundation—which backed the team's entry—and Mitsuyuki Unno, executive director of the Ocean Affairs Division at The Nippon Foundation (Figure 53-17).

Rochelle Wigley (PI) and Tomer Ketter (co-PI) submitted a Technical Proposal titled, "Uncrewed, Over the Horizon, Swath Bathymetry Mapping," in response to the 2019 ONR BAA Announcement # N00014-18-S-B007. This technical proposal will further develop the mapping potential of the USV developed through the Shell Ocean Discovery XPRIZE challenge and addresses Topic 7: Integration and demonstration of a cost-effective autonomous system and methodology for deep ocean mapping and environmental characterization. This application was unfortunately not successful.

The GEBCO-Nippon Foundation Alumni Team started working with Wetherbee Dorshow of Earth Analytic, Inc. during the Shell Ocean Discovery XPRIZE challenge where they pioneered remote processing of multibeam data collected during the Round 2 field tests on a virtual machine. The collected multibeam data were processed on a virtual machine supported by Earth Analytic, Inc. and data products were produced and shared remotely. Some of the Nippon Foundation/GEBCO training program alumni are going to continue working Earth Analytic, Inc to assess this methodology

and understand impacts on virtual access to software, robustness of the approach and management of multiple global users accessing data. Qimera will support this research and development by the supply of a software license to the virtual machine so that the team can, through testing, help understand the problems and technical difficulties associated with this approach to licensing and accessing software. The first results of this work were presented at the Fall 2019 AGU Meeting.

Alumni of the training program have been active in GEBCO over the last year, with Amon Kimeli in attendance at the annual SCUFN meeting, the Vision to Action meeting as well as the annual 36th Joint IHO-IOC Guiding Committee for GEBCO and Sub-committees: TSCOM and SCRUM meetings and the Map the Gaps symposium, with 15 alumni in attendance (Figure 53-18). In addition, three alumni are currently employed at regional data centers for the Nippon Foundation-GEBCO Seabed 2030 project and four alumni did internships/lab visit at a regional data center in 2019. Alumni also acted as ambassadors for Seabed 2030 project at the WIOMSA symposium and the Conference on Fisheries and Coastal Environment 2019 in Ghana.

Two alumni, Jaya Roperez and Tinah Martin, also presented at the 2019 Global Ocean Science Education Workshop in Partnership with the Atlantic Ocean Research Alliance and Seabed 2030 Project from November 13-15 in Washington, DC.



**Project: Extended Training**

**JHC Participants:** JHC Faculty

**NOAA Participants:** Andy Armstrong, JHC/OCS, and Rick Brennan, OCS

**Other Collaborators:** Many JHC Industrial Partners and Other Labs

With our fundamental education programs in place, we are expanding our efforts to design programs that can serve undergraduates, as well as government and industry employees. We have a formal summer undergraduate intern program we call SURF (Summer Undergraduate Research Fellowship), we host NOAA Hollings Scholars, and we continue to offer the Center as a venue for industry and government training courses and meetings (e.g., CARIS, Triton-Elics, Geoacoustics, Reson, R2Sonics, QPS, ESRI, GEBCO, HYPACK, Chesapeake Technologies, IBCAO, Leidos, the Seabottom Surveys Panel of the U.S./Japan Cooperative Program in Natural Resources (UJNR), FIG/IHO, NAVO, NOAA, NPS, ECS Workshops, USGS, Deepwater Horizon Subsurface Monitoring Unit, and others). In 2019, we hosted short courses from CARIS, QPS, and HYPACK, as well as several NOAA and other inter-agency meetings on a range of topics. These meetings and courses have proven very useful because our students can attend

them and be exposed to a range of state-of-the-art systems and important issues. In particular, in August of 2019 we hosted a NOAA Precision Navigation Workshop which brought both NOAA and Center scientists together to focus on various aspects of the Precision Navigation project.

Center staff is also involved in training programs at venues outside of the Center. John Hughes Clarke, Larry Mayer, and Tom Weber continue to teach (along with David Wells and Ian Church) the internationally renowned Multibeam Training Course. In 2019, the course was taught in New Orleans and Aberdeen, Scotland. Larry Mayer regularly teaches at both the Rhodes (Greece) and Yeosu (Korea) Academies of Law of the Sea. Also in 2019, UNH hosted the world-renowned acoustics short course “Marine Acoustics, Sonar Systems, and Signal Processing,” organized by Center members Anthony Lyons and Jennifer Miksis-Olds.



Figure 53-19. Participants of the Marine Acoustics, Sonar Systems, and Signal Processing short course.



## Research Requirement 4.B: Acoustic Propagation and Marine Mammals

**FFO Requirement 4.B:** “Development, evaluation, and dissemination of improved models and visualizations for describing and delineating the propagation and levels of sound from acoustic devices including echo sounders, and for modeling the exposure of marine animals to propagated echo sounder energy.”

**TASK 54: Modeling Radiation Patterns of MBES:** *Develop realistic models of the ensonification patterns of the sonar systems that we use for mapping. Pls: Tom Weber and Xavier Lurton*

### Project: Modeling Radiation Patterns of MBES for NEPA Requirements

**JHC Participants:** Mike Smith, Tom Weber, Tony Lyons, Kevin Jerram, Carlo Lanzoni, Paul Johnson, Larry Mayer, and Val Schmidt

**Other Participants:** Xavier Lurton, IFREMER

#### Deep Water MBES: EM122 and EM302

Multibeam Echo Sounders (MBES) are tools used to collect geophysical information from both the seafloor and the water-column. Calibration of the transmit array provides direct measurements of the ensonification pattern which is necessary for precise calibration of backscatter intensity and can also provide information on how the use of the MBES contributes to localized soundscapes. At high frequencies (>100 kHz), MBES

can be calibrated for their ensonification pattern in acoustic test tanks. However, low frequency deep water MBES have transmit array lengths on the order of several meters and near-field radiation patterns extending hundreds of meters from the array, making tank calibration impractical. We have been working on methods by which to quantitatively assess deep water MBES radiation patterns using moored hydrophones in a suite of at-sea experiments.

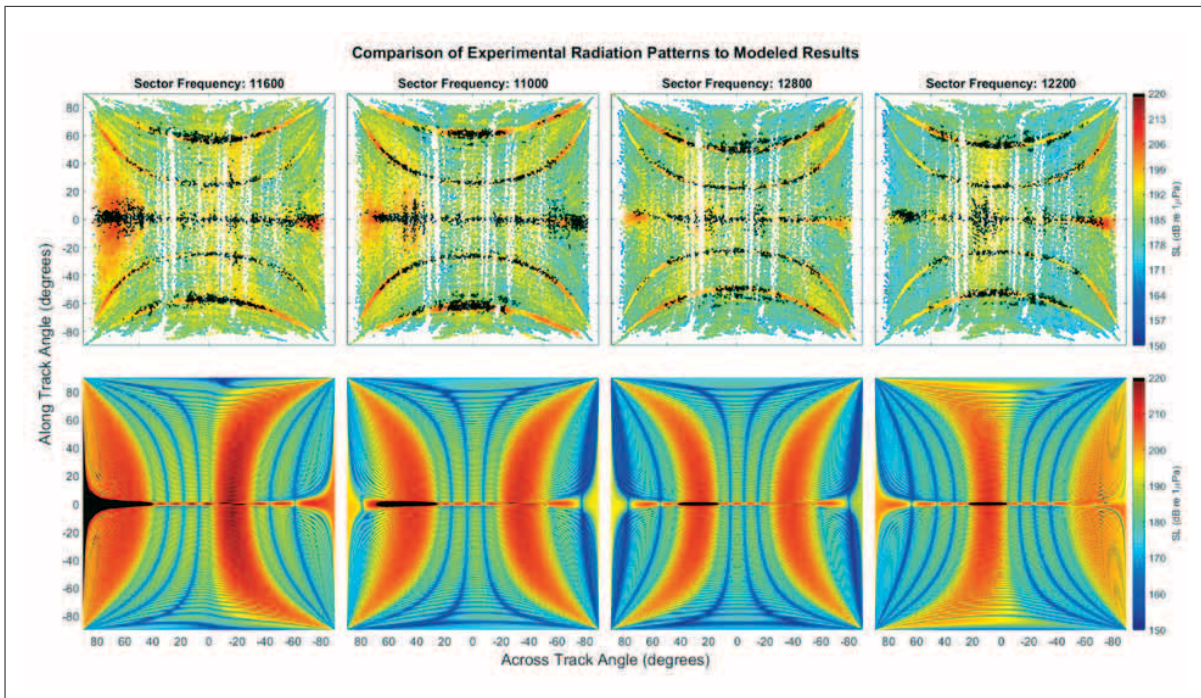

Figure 54-1. Comparison between experimental results and theoretical models of the EM122 radiation patterns of the portside sector of the first swath. The data are plotted in athwartship versus alongship angle. The color corresponds to the equivalent far field source level at 1m. Black within the experimental data corresponds to clipped detections and in the model provides estimates of where clipping was expected.

A first experiment aimed at deep water MBES calibration was conducted in 2017 at the Southern California Offshore Range (SCORE), located off the coast of San Clemente Island, California. The experiment utilized a bottom mounted hydrophone array operated by the U.S. Navy and was able to measure the full two-dimensional radiation pattern of a 12kHz Kongsberg EM122 deep-water MBES (Figure 54-1). However, a significant portion of the data were found to be clipped due to a previously unknown equipment limitation.

The results from the 2017 work revealed the presence of two frequency-dependent lobes positioned in front and behind the vessel. The unexpected presence of these lobes within the EM122 radiation pattern and the limited ability to define them due to clipping formed the basis for the design and execution of additional experiments.

In December of 2018, a second experiment was conducted at the Atlantic Undersea Test and Evaluation Center (AUTEC) in the Bahamas. This study was conducted aboard the NOAA Ship *Okeanos Explorer* and ran survey lines over the AUTEC hydrophone array with a 30kHz Kongsberg EM302 MBES. To avoid encountering the same issue of clipping that occurred with the SCORE array, the Center contracted JASCO to deploy a custom designed mooring as the primary measurement and recording device (Figure 54-2). Three distinct tests were designed to investigate the potential presence of these lobes and the method of generation. The U.S. Navy is still currently conducting an internal review to

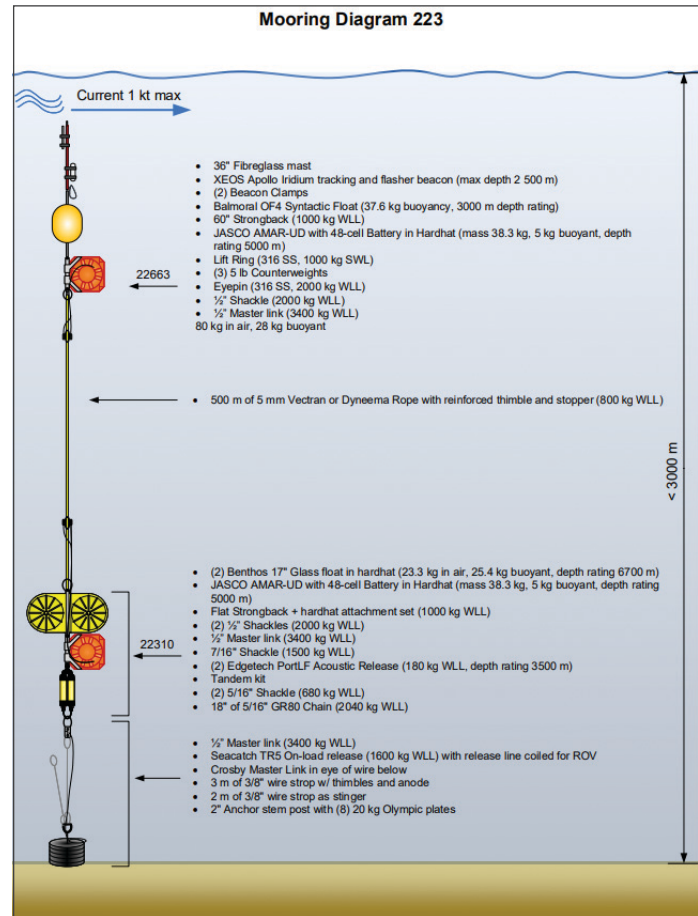

Figure 54-2. Notional mooring diagram provided by JASCO and deployed at both AUTEC in December 2018 and at SCORE in January 2019.

publicly release the data. However, a short segment of time during one of the experiments was provided for a preliminary check on data quality (Figure 54-3). During the recording shown in Figure 54-3, the

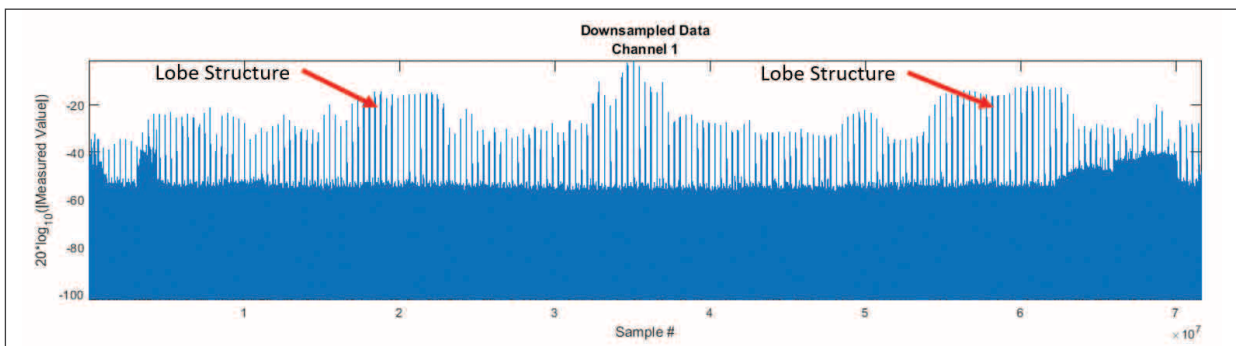

Figure 54-3. Time series data collected by the JASCO mooring. Data is plotted as sample number versus raw voltage. Note the presence of high response regions indicative of the same radiation pattern characteristics observed in the SCORE 2017 work.



Test	Primary Measurement	Priority
Baseline Radiation Pattern Characterization	Direct measurements of uncompensated TX beam pattern	1
Alongship Steering Experiment	Measurement of radiation pattern with fixed adjustments of alongship tilt	2
SEL and Radiated Field Measurements	MBES in standard operating mode mapping over hydrophone range	3

Table 54-1. Table of Experiments run for both the SCORE 2019 experiment and the AUTEC 2018 experiment.

EM302 was operating in single swath mode, with continuous wave transmissions and active motion compensation. The time series structure observed is reminiscent of the time series data seen in the 2017 SCORE work. This suggests that the lobe structures observed in 2017 are not restricted to the particular sonar or model tested.

In January of 2019, a third experiment was conducted, once again at SCORE. For this experiment, the same EM122 on the R/V *Sally Ride* from the 2017

SCORE work was used. This experiment utilized two of the JASCO moorings to increase the sampling density of the results. The experiment was comprised of three tests which restricted the settings of the EM122 (see Table 54-1). The results of this test have been processed, with the results shown in Figure 54-4. The Baseline test results show that the grating lobes are still present in the non-motion compensated radiation pattern and are consistent with the results from 2017. Further, the measurement of the full, unclipped levels allows for inspection

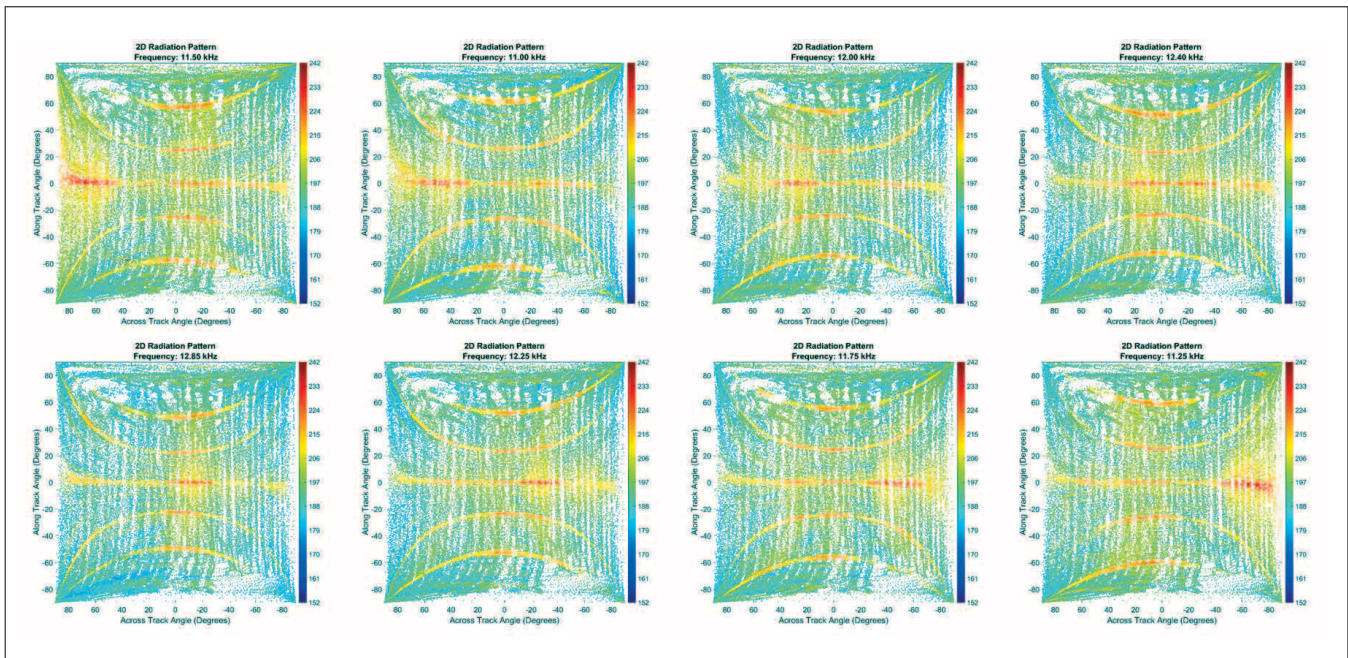

Figure 54-4. Baseline Radiation Pattern test results. Each plot is a top-down, 2D representation of the 3D transmit radiation pattern of a given sector. Data was plotted in the across versus along track and the color corresponds to the equivalent far field source level at 1m as measured by the hydrophones. main beam response and ending after the second lobe generated on the aft end of the vessel. Data is presented in equivalent source level at 1m using an approximate transmission loss correction for the slant range. Black arrows point to the main beam and the additional lobes.



of relative levels between the main beam and the grating lobes (Figure 54-5). Of further note is the remarkably large sidelobe level suppression.

The results of the December 2018 work show that EM302 also generates grating lobes. Further, the relative levels plot (Figure 54-6 right) shows that there are many more grading lobes present within

the EM302 radiation pattern. This behavior is expected for a high frequency system if the generation mechanism is the same or similar between the EM302 and EM122. These results demonstrate that the grating lobes are not limited to a single MBES model and suggests a consistent mechanism of generation that is shared between the various deep-water MBES models evaluated.

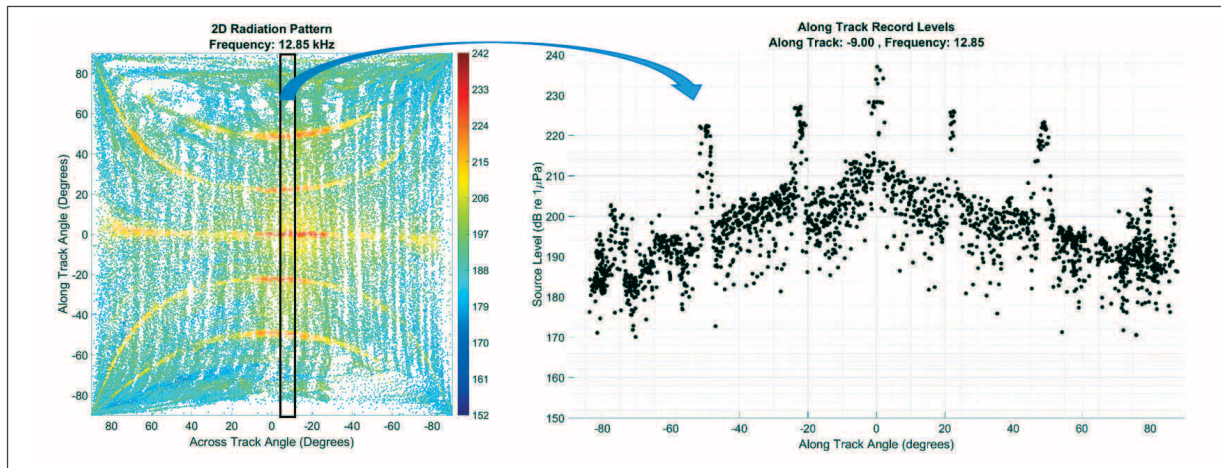

Figure 54-5. Inspection of the relative levels between the main beam and the grating lobes. The data points contained within the box on the left hand figure are plotted in along track versus source level. It can be seen that the inner grating lobes are 10dB down from the main beam and the outer lobes are approximately 15dB down from the main beam.

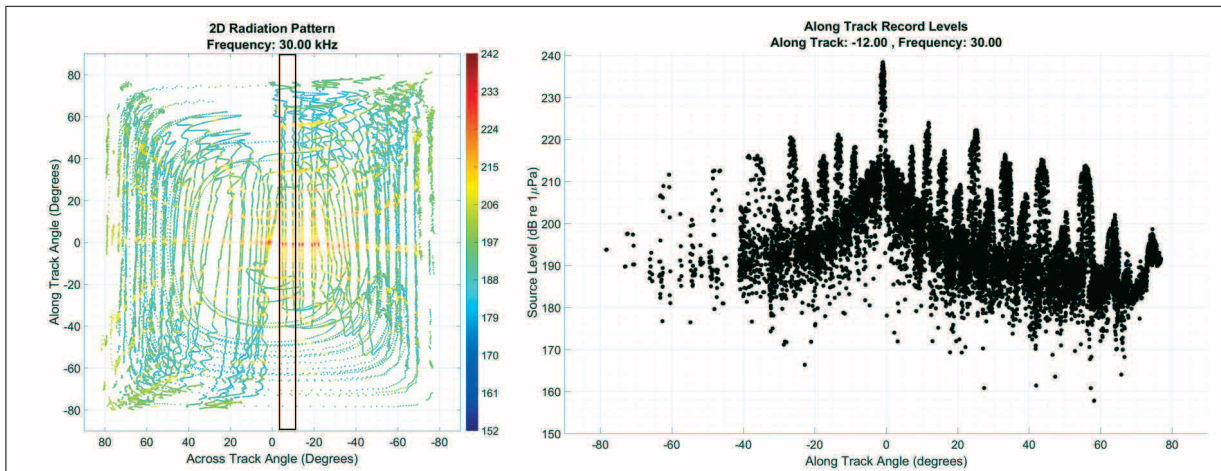

Figure 54-6. The radiation pattern of a single sector of the EM302. On the left is the 2D representation of the 3D radiation pattern. Color denotes the experimentally derived far field source level at 1m. All data points contained within the black box were plotted in the figure to the right.

**TASK 55: Web-based Tools for MBES Propagation:** Use Lurton’s models and produce web-based tools for understanding and visualizing sonar ensonification patterns and performance. PI: **Roland Arsenault**

JHC Participant: Roland Arsenault

Other Participant: Xavier Lurton

This task is complete. The resulting webpage can be found at [http://vislab-ccom.unh.edu/~roland/acoustics/mbes\\_performance.html](http://vislab-ccom.unh.edu/~roland/acoustics/mbes_performance.html).

**TASK 56: Impacts of Sonars on Marine Mammals:** Continue to convene small working groups representing various federal agencies to discuss the common problem of understanding the potential impact of mapping sonars on marine mammals as well as to pursue the possibility of taking a multibeam sonar to a Navy acoustic calibration range. PIs: **Jennifer Miksis-Olds and Bill Ellis**

**Project: Acoustic Propagation and Marine Mammals**

**JHC Participants:** Jennifer Miksis-Olds, Hilary Kates Varghese, Mike Smith, Larry Mayer, and Tom Weber

**NOAA Participants:** Andy Armstrong

**Other Participants:** Xavier Lurton, IFREMER; Dave Moretti and Susan Jarvis, NUWC

The focus of this task has evolved and broadened from the impacts of mapping sonars on marine mammals to the impacts of mapping sonar on marine life and the acoustic environment in general. Previously, the estimation of marine mammal Level B takes as outlined by the Marine Mammal Protection Act (MMPA) in response to exposure to high frequency scientific and mapping sonars was identified as a highest priority in the early stages of the newly executed Center grant (2016-2017). Marine mammal takes were generated and accepted during the 2017 reporting period by the NOAA Office of Coast Survey to meet the environmental requirements for approval to conduct Center ocean mapping activities. Best Management Practices (BMPs) were approved for: 1) activities related to ground disturbance under the Historical Preservation Act for heritage sites, 2) environmental assessment of marine life under the jurisdiction of the United States Fish & Wildlife Service (USFWS) protected by the Endangered Species Act (ESA), 3) assessment of planned activities by the state of New Hampshire in accordance with the Coastal Zone Management Act (CZMA), and 4) estimated marine mammal takes related to the MMPA.

Following the immediate need to obtain environmental approvals for the Center to conduct its activities, effort was shifted in 2018 to further understanding the potential effects of ocean mapping sonar on marine mammals. Two ocean mapping surveys using an EM 122 (12 kHz) Kongsberg multibeam echosounder were conducted over the SCORE hydrophone range off of San Clemente Island, California in 2017 and 2019 in order to characterize the radiation pattern of the sonar system. This provided the opportunity to study the impact of high frequency (10+kHz) mapping sonar on the foraging behavior of beaked whales. Results from the 2017 effort indicated that exposure to 12 kHz mapping sonar activity did not cause the cessation of feeding in Cuvier's beaked whales. This is in contrast to the cessation of feeding of Blainville's beaked whales in response to mid-frequency military sonar (McCarthy et al., 2011). In January 2019, a second ocean mapping

survey was conducted on SOAR to contribute to the behavioral effects study from 2017. Additionally, effort this year was devoted to quantifying the contribution of the EM 122 echosounder to the local soundscape in different operation modes. Understanding the source contribution of the EM 122 echosounder to the local environment will better inform the interpretation of results in current and future impact studies.

**Impacts of Sound on Marine Mammals**

An ocean mapping survey was conducted aboard the R/V *Sally Ride* during January 2019 on the Southern California Antisubmarine Warfare Range (SOAR) using the hull-mounted Kongsberg EM 122. This study was similar to one conducted in 2017 which examined the radiation pattern of the EM 122 multibeam system. However, due to limitations in the dynamic range of the hydrophones at SOAR in 2017, the absolute SPLs could not be obtained for the closest points of approach. This study (2019) deployed a more sensitive hydrophone array mooring through collaboration with JASCO Applied Sciences to determine the radiation pattern of the MBES. This also provided the opportunity to collect another data set to examine the effect of the ocean mapping survey on resident Cuvier's beaked whales.

Following on the behavior assessment conducted in 2017 (Mayer 2018) assessing the potential effect of the EM 122 signal on beaked whale foraging behavior, a similar data set of beaked whale echolocation clicks were collected during the 2019 mapping survey and analyzed. Four characteristics of the Group Vocal Period (GVP), a collection of echolocation clicks produced by a group of animals foraging together, were used as proxies to assess changes in foraging behavior across different exposure periods of the MBES survey (Table 1). These included the number of GVP per hour, the number of clicks per GVP, GVP duration, and click rate. For each GVP characteristic, the GVPs detected on all of the range hydrophones were binned into one-hour increments based on the start time of the GVP and the GVP characteristics computed.

A series of hypothesis tests were performed with the null hypotheses detailed below.

- H01: The number of GVP per hour was the same across all exposure periods.
- H02: The average GVP duration was the same across all exposure periods.
- H03: The average number of clicks per GVP was the same across all exposure periods.
- H04: The average click rate was the same across all exposure periods.

See Figure 56-1 for the track lines of the vessel during the periods the vessel was on the SOAR and Table 56-1 for descriptions of these periods.

Kruskal-Wallis tests were used to compare exposure periods for each of the GVP characteristics since none of the variables satisfied the normality assumption of an ANOVA. There were no statistically significant differences across the exposure periods for the number of GVP per hour [H (5) =5.77, p=0.3292]; the number of clicks per

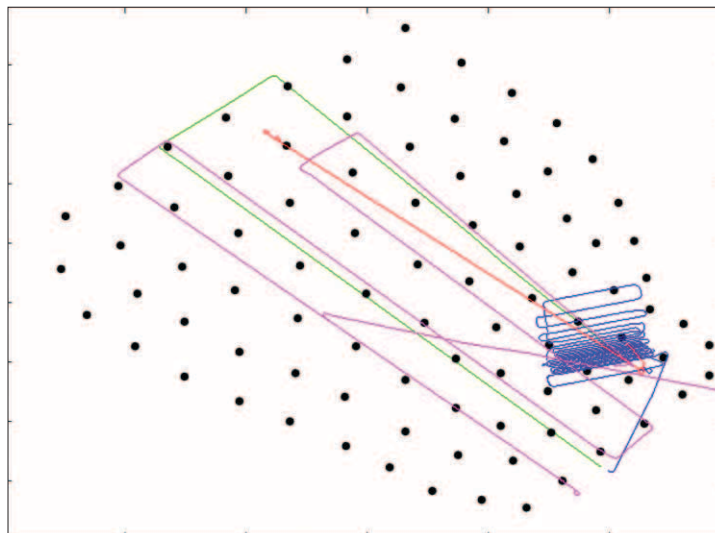

Figure 56-1. Track lines of the 2019 study when the vessel was on the range during the Control Survey, Corner Survey, Across Range Survey, and Traditional Survey.

GVP [H (5) =2.82, p=0.7276], or click rate [H (5) =3.54, p=0.6169]. See Table 56-2 for descriptive statistics and Figure 56-2, which shows the hourly binned data across the six exposure periods for each of these three GVP characteristics.

Exposure Period	Date and Time	Description
Before	1/3/19 07:11:00 – 1/4/19 07:11:00	24 hours, immediately preceding control survey; MBES inactive; vessel off-range
Control Survey	1/4/19 07:11:00 – 1/4/19 12:11:00	~5 hours; MBES inactive
Control Survey	1/4/19 12:19:00 – 1/5/19 12:19:00	~24 hours; EM 122 active in single swath CW only mode for 1st 19 hours, final hours forced tilt between 2°-10°; motion compensation off throughout
Across Range Survey	1/5/19 14:58:00 – 1/5/19 22:58:00	~ 8 hours; EM 122 active 1st-2nd lines: single swath CW only mode, motion compensation on; 3rd-4th lines: dual swath FM-enabled mode, motion compensation on
Traditional Survey	1/6/19 02:00:00 – 1/6/19 16:00:00	~ 14 hours, EM 122 active in dual swath FM-enabled mode, motion compensation on
After	1/6/19 16:00:00 – 1/7/19 16:00:00	24 hours, immediately following vessel leaving the range, MBES inactive, vessel off-range

Table 56-1. Descriptions of MBES settings during the exposure periods from 2019, including duration of exposure period, acoustic systems that were active, and other operator inputs. The vessel was on the range during all periods where vessel location is not noted explicitly.



	Before	Control Survey	Control Survey	Across Range Survey	Traditional Survey	After
Number of GVP per hour	2.46 ± 2.43 (n=24)	3.6 ± 1.52 (n=5)	2.67 ± 2.06 (n=24)	4.38 ± 2.77 (n=8)	2.57 ± 1.34 (n=14)	2.42 ± 1.93 (n=24)
Number of clicks per GVP	3002.3 ± 2042.18 (n=17)	2975.85 ± 1289.52 (n=5)	2424.13 ± 1510.87 (n=21)	2248.53 ± 923.14 (n=8)	2287.23 ± 1226.76 (n=13)	2478.17 ± 1229.01 (n=20)
GVP duration (min)	49.53 ± 12.42 (n=17)	40.54 ± 14.65 (n=5)	40.41 ± 11.46 (n=21)	36.60 ± 12.29 (n=8)	31.83 ± 11.91 (n=13)	42.88 ± 9.54 (n=20)
Click rate (clicks/min)	63.19 ± 39.82 (n=17)	69.96 ± 14.35 (n=5)	56.12 ± 29.11 (n=21)	59.59 ± 19.93 (n=8)	65.48 ± 31.66 (n=13)	56.19 ± 34.34 (n=20)

Table 56-2. Descriptive statistics for the four GVP characteristics during the 2019 MBES study, including the mean and standard deviation for each exposure period and number of samples used to compute those values in parentheses.

There was a statistically significant difference among exposure periods for GVP duration [H(5) = 14.53, p=0.0126]. GVPs were shorter in duration during the Traditional Survey than Before (p=0.004). See Table 56-2 for descriptive statistics and Figure 56-3, which shows the hourly averaged data across the six exposure periods for this metric.

Similar to the results of the 2017 study (Mayer 2018), there is not a clear change in foraging behavior of beaked whales at the SOAR in response to the EM 122 survey. For three of the four metrics, there was

no change in foraging behavior across the exposure periods analyzed. The only significant difference observed in any of the GVP characteristics during the 2019 survey was in GVP duration. The GVP duration steadily shortened from the **Before** period through the *Traditional Survey* and then increased again **After**. The only significant difference in this trend was between the **Before** period and the Traditional Survey (Figure 56-3). One interpretation of this is that the particular lines run may have affected this foraging behavior metric in line with predictions. A spatial analysis of this same data set is anticipated in 2020

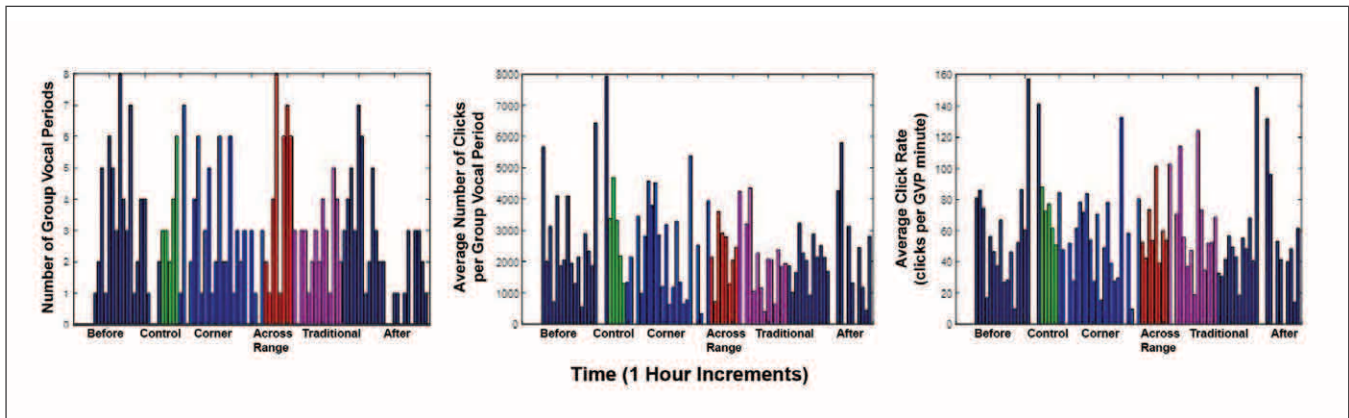

Figure 56-2. Bar graphs of the three GVP characteristics where no differences were found across exposure periods in the 2019 survey. Each graph shows the data binned into hour increments for each of the six exposure periods.

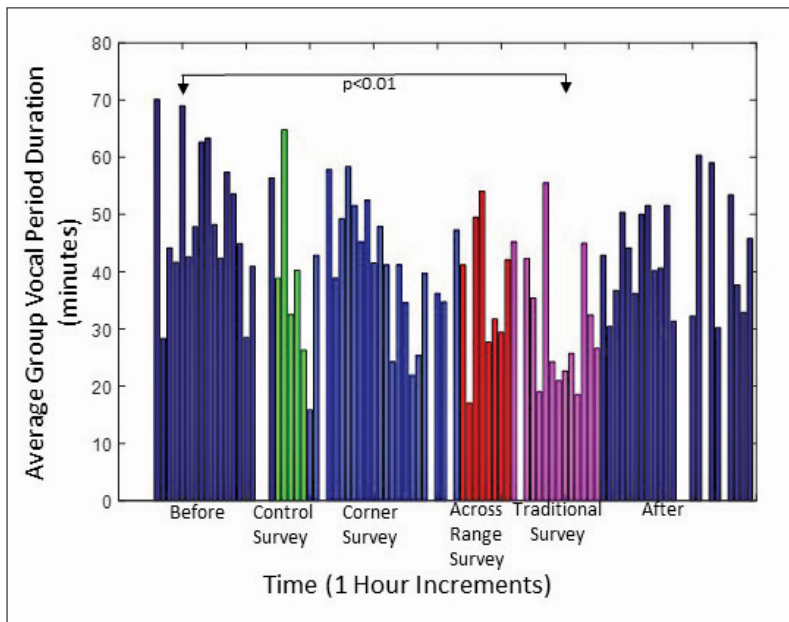

Figure 56-3. Bar graph showing the average GVP duration in minutes for each hour during the six exposure periods of the 2019 survey. The arrows indicate statistically significant differences at the p-value indicated between the two exposure periods corresponding with the arrows.

and should provide insight into this result and its interpretation. Overall, there was not widespread change in foraging behavior during the MBES survey that would suggest that the MBES activity impacts foraging at this coarse scale. In addition, the animals did not stop foraging and did not leave the SOAR during the MBES survey. This is a different response from beaked whales during MFAS sonar activity on the SOAR, where the same species decreased foraging during MFAS activity (DiMarzio et al. 2019).

The results of this work on the effect of MBES on beaked whale foraging behavior as well as those from 2017 (Mayer 2018) were compiled into a manuscript and submitted in December 2019 to *The Journal of the Acoustical Society of America* for inclusion in a special issue on, "The Effects of Noise on Aquatic Life."

**MBES Soundscape Contribution**

A soundscape study was initiated to assess the contribution of an ocean mapping multibeam echosounder to the local acoustic environment. In particular, the hydrophone data from the 2017 mapping survey that used a Kongsberg EM 122 (12 kHz) multibeam echosounder (MBES) at the Southern California Antisubmarine Warfare Range (SOAR) was analyzed. The raw hydrophone data from the SOAR range was extracted, converted to sound

pressure levels (SPL), and adjusted for the receive sensitivity and gain of the hydrophones. A novel frequency correlation approach was used to generate frequency correlation difference plots to examine changes in the local soundscape across three time periods: 1) baseline, 'Before,' 2) ship noise only, 'Control,' and 3) ship noise + EM 122, 'EM 122.'

Three hydrophones were selected to provide a first order understanding of the contribution of the 12 kHz EM 122 to the marine soundscape: hydrophones 209, 404, and 204 (Figure 56-4). Spectrograms (Figure 56-5), spectral probability density plots (Figure 56-6), frequency correlation images (Figure 56-7), and frequency correlation difference plots (Figure 56-8) were created for each time period and source category. The spectrograms visually show how the sound energy is distributed with respect to time (x-axis) and frequency (y-axis). The spectral probability density plots show how the variance in sound levels is distributed with respect to frequency. These are overlaid with percentiles to capture the distribution of SPLs of each time period.

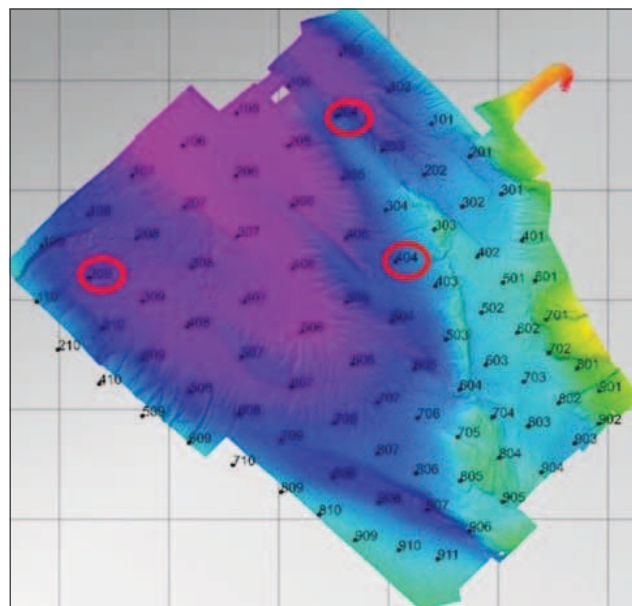

Figure 56-4. Hydrophone range with the three hydrophones 209 (left), 404 (center), and 204 (upper right) analyzed in the preliminary study indicated by a red circle.

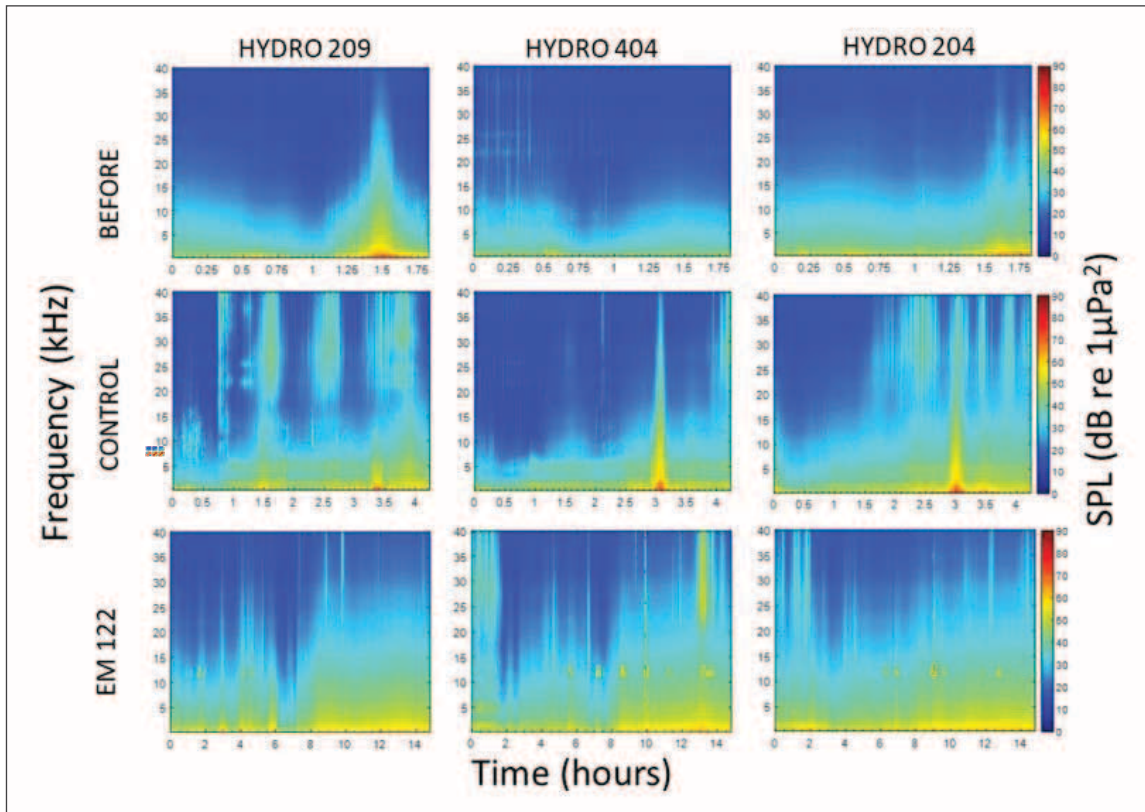

Figure 56-5. Spectrograms for each of the three hydrophones 209 (left), 404 (center), and 204 (right) during the Before (top), Control (center), and EM 122 (bottom) time periods.

For example, the 10% line represents the sound level for each frequency bin below which 10 percent of the data falls. The frequency correlation plots show how frequency autocorrelates in each time period. When two frequencies are highly correlated, the energy in those frequencies is likely driven by the same source mechanism (e.g., vessel noise, MBES signal, acoustic biological activity, etc.). These are symmetric plots where the upper triangle contains the same information as the bottom triangle, so only one triangle needs to be examined.

The spectrograms (Figure 56-5) were generated and compared to a video that time steps through the location of the vessel, with respect to the range. This exercise revealed that another vessel was likely transiting near the northern part of the range closest to hydrophone 209 and 204 approximately 1.5 hours into the Before period (Note: energy shows up in the spectrogram at 1.5 hours, but due to the sampling duty cycle: 5 min on/5 min off, this equates to three hours in real-time). It is likely not the R/V *Sally Ride* because the energy is not seen on the hydrophone

404 spectrogram, despite it being the closest hydrophone (of the three) to the R/V *Sally Ride* at this time. In general, there is continuous, low frequency energy (<20 kHz) throughout the Before time period (Figure 56-5, top row). There is also some broadband (20-40 kHz) but temporally short bursts of energy visible on all the hydrophones, especially evident on hydrophone 404 during this time period, likely associated with acoustic biological activity. In the Control period (Figure 56-5, center row), higher SPLs are visible across a broad band of frequencies at approximately 3-3.5 hours (real-time: 6-7 hours), with most of the energy centered at lower frequencies, indicative of vessel noise. This correlates with the time when the vessel was sitting in the center of the hydrophone range. In the EM 122 survey (Figure 56-5, bottom row), in addition to an increase in the SPLs across the lower frequencies, there are distinct periods where there are higher SPLs in the 11-13 kHz band on all hydrophones. This pattern occurs at different times on each hydrophone and is correlated to when the vessel is within 10-15 km of the respective hydrophone. For example, the vessel and MBES are near



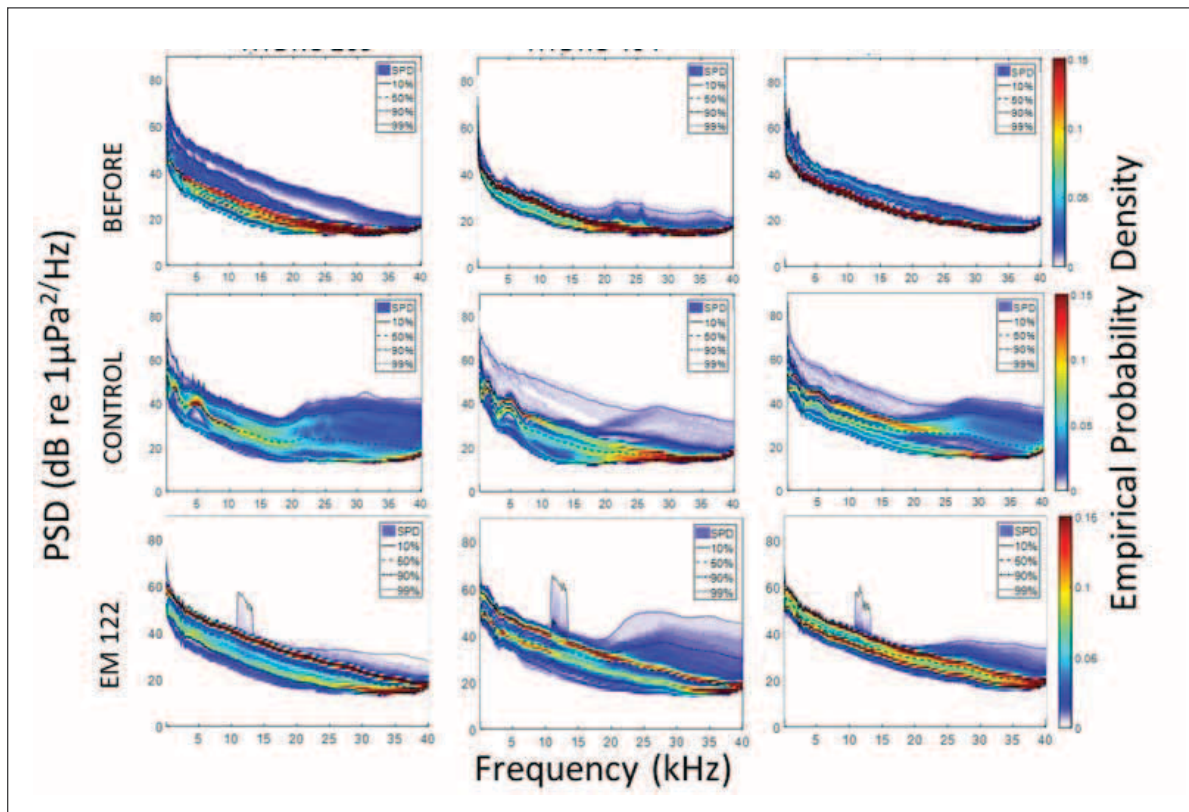

Figure 56-6. Spectral probability density plots for each of the three hydrophones 209 (left), 404 (center), and 204 (right) during the Before (top), Control (center), EM 122 (bottom) time periods overlaid by 10th (solid), 50th (dashed), 90th (dashed and dotted) and 99th (dotted) percentiles.

hydrophone 209 at approximately two hours into the survey, and this is visible in the spectrogram. It is not until roughly after the sixth hour of this time period that the MBES signal is visible on hydrophones 404 and 204, when the vessel was closest to these hydrophones. At this deep water location, the range of detection for the MBES signal was 10-15 km.

Spectral probability density (SPD) plots were generated for each hydrophone during each exposure period. In general, there is not a wide distribution of sound levels in the Before period (Figure 56-6, top row), except on hydrophone 209 that appears to have been the closest hydrophone to a loud broadband sound source of noise, thought to be another vessel. In the Control (Figure 56-6, center row), there is a wider distribution of sound levels with respect to power spectral density and a noticeable aggregation of elevated sound levels centered at 2 and 5 kHz in comparison to the Before period. The SPD plots for the EM 122 period (Figure 56-6, bottom row) have a similar distribution to the Control, with the addition of elevated levels in 11-13 kHz frequency band. Refer-

encing the 90% line, roughly 10% of the SPL data lies above this line at these frequencies, indicating that the MBES signal impact on the local soundscape is confined to the 11-13 kHz band and impacts only 10% of the overall soundscape in the 11-13 kHz range.

Frequency correlation plots were generated for each time period for hydrophone 404 (Figure 56-7, bottom row) and compared to the spectrograms (Figure 56-7, top row) in order to understand the source mechanism driving the frequency correlations. There were two distinct areas of high correlation in the Before period (left column). The first area (150 Hz-20kHz) is typical of a continuous, low frequency ambient acoustic environment. The second frequency area (20-40 kHz) resembles the echolocation click of beaked whales and may therefore represent biological activity in the area. In the Control period, there is an area of higher correlation centered around 2 and 5 kHz, which can be attributed to the vessel noise, as it becomes more prominent in the spectrogram when the vessel gets closer to the hydrophone (Figure 56-7, center column). The 2 and 5 kHz areas of increased

correlation in the Control also appear during the EM 122 Survey (right column), since the vessel noise was still present. Additionally, there are bands between 11-13 kHz that have lower correlation with respect to both lower frequencies and higher frequencies. This is credited to the MBES signal that is distinct in comparison to any other sound source present in the data during this time.

The goal of this work component is to quantitatively compare soundscapes across exposure periods and identify differences with respect to MBES signals. This was achieved with the frequency correlation plots by subtracting two time periods. The frequency correlation plots generated in Figure 56-7 were taken and subtracted from each other, creating frequency

correlation difference plots shown in Figure 56-8. The left figure shows frequency correlation differences (reds and yellows) between the Before and Control, which represents differences due to the vessel being present on the range. The middle figure shows differences between the Before and EM 122 period, which not only shows the differences due to the vessel noise, but also from the MBES signal. The contribution of the MBES signal alone is clearer to see in the right figure which shows differences in frequency correlation between the Control and EM 122 periods, which removes the inherent vessel-related noise. This year's effort successfully demonstrates a method for decomposing the soundscape and separating the MBES signal from vessel noise, which will be critical to assessing animal response to MBES surveys.

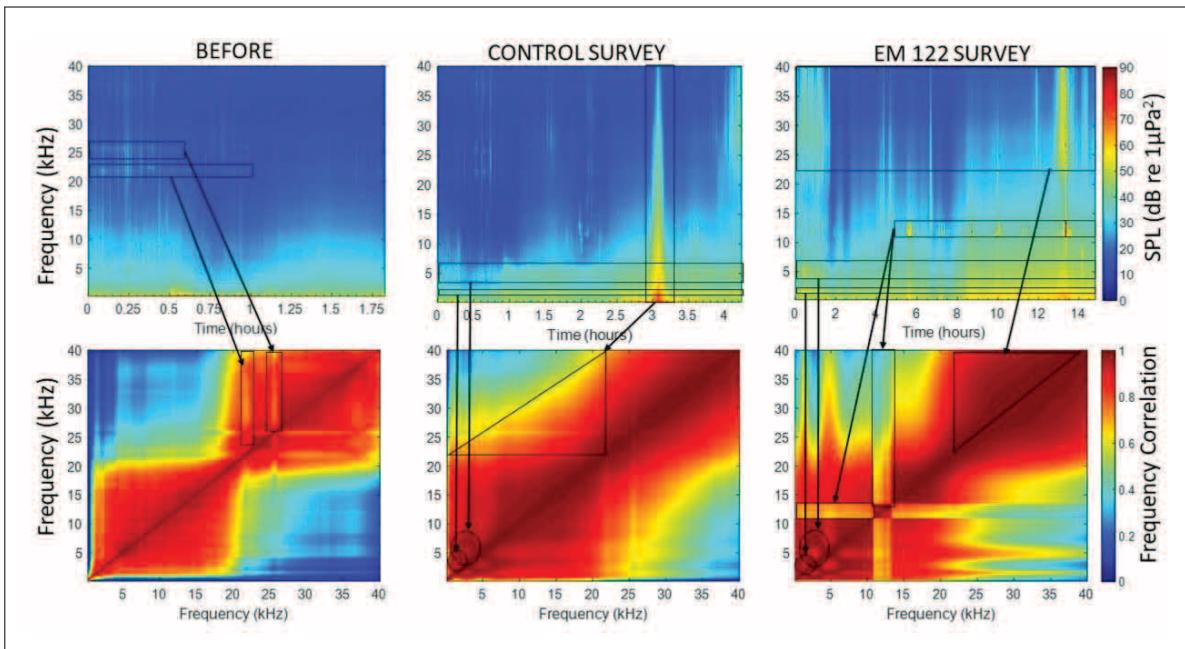

Figure 56-7. Frequency correlation plots for the three time periods on hydrophone 404 (bottom row) in comparison to respective spectrograms (top row). Black boxes and arrows indicate how the content of the two plots relate.

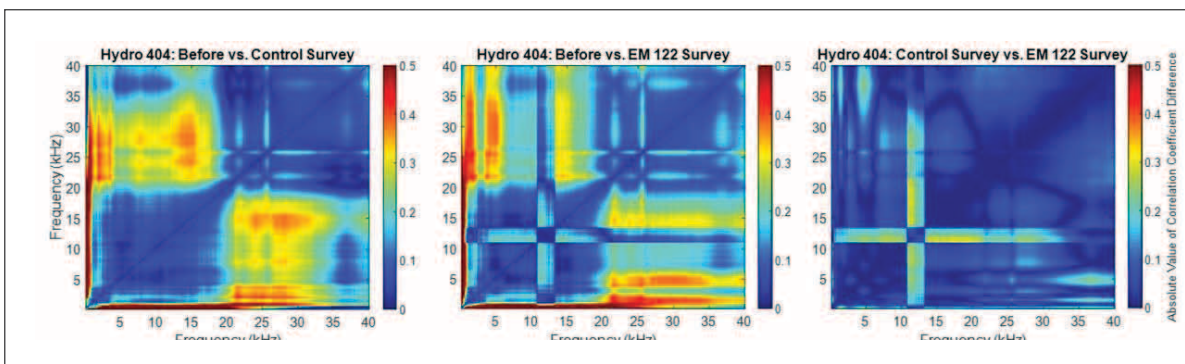

Figure 56-8. Frequency correlation difference plots, comparing each pair of time periods on hydrophone 404.

## Research Requirement 4.C: Publications and R2O

**FFO Requirement 4.C:** “Effective delivery of research and development results through scientific and technical journals and forums and transition of research and development results to an operational status through direct and indirect mechanisms including partnerships with public and private entities.”

**TASK 57: Continue to Publish, Make Presentations and Promote R2O Transitions. PIs: Lab-wide**

Members of the Center continue to actively publish their results in refereed and other journals, make numerous presentations and transition their research to NOAA and others. A complete list of Center publications, conference and other presentations, reports, and theses can be found in Appendices D and E.

## Research Requirement 4.D: Outreach

**FFO Requirement 4.D:** “Public education and outreach to convey the aims and enhance the application of hydrography, nautical charting, and ocean and coastal mapping to safe and efficient marine navigation and coastal resilience.”

**TASK 58: Expand Outreach and STEM Activities**

Expand our activities including participation in the Ocean Exploration Trust’s Community-Based STEM Initiative, working with the Marine Advanced Technology Education (MATE) Center (designed to train a marine technology workforce) and developing closer ties with the Shoals Marine Lab. **PI: Tara Hicks-Johnson**

Keep the public informed about our research and activities, and maintain a repository of technical and scientific resources. **PI: Colleen Mitchell**

In addition to our research efforts, we recognize the interest that the public takes in our work and our responsibility to explain the importance of what we do to those who ultimately fund our work. We also recognize the importance of engaging young people in our activities to encourage a steady stream of highly skilled workers in the field. To this end, we have upgraded our web presence and expanded our outreach activities. Outreach Specialist Tara Hicks-Johnson joined our staff in 2011. She coordinates Center-related events, represents the Center on

committees and at meetings, and is the friendly face the Center presents to the public. Graphic Designer Colleen Mitchell, who joined the Center in 2009, is responsible for the communications side of outreach, managing the Center’s website and social media, and using her design skills to translate the Center’s mission through print and digital mediums.

The Center continued to attract significant media attention during this reporting period, including articles in *Science*, *Scientific American*, and on the BBC.

### JHC/CCOM Media Coverage

Jan. 10	Tech Tidbits From Around New Hampshire	<i>NH Business Review</i>
Jan. 16	In the Weeds	<i>UNH Today</i>
Feb. 14	URI Names New \$125 Million Research Ship “Resolution”	<i>GoLocalProv News</i>
Feb. 19	Hydrographic Hall of Fame	<i>UNH Today</i>
Mar. 11	Five Deeps Expedition to Share Bathymetric Data	<i>The Maritime Executive</i>
Mar. 11	Major Partnership Announced Between the Nippon Foundation-GEBCO Seabed 2030 Project and the Five Deeps Expedition	<i>Directions Magazine</i>
Mar. 22	Next in XPRIZE	<i>SPARK</i>
Apr. 5	SeaPerch Program Puts Underwater Robotics Teams to the Test	<i>Union Leader</i>
Apr. 16	Charting New Courses: From GEBCO Alum to Seabed 2030	<i>UNH Global News</i>
May 4	NOAA to Map Lake Bottom This Summer	<i>Alpena News</i>



May 6	Seafloor Maps Reveal Underwater Caves, Slopes—and Fault Lines	<i>Wired</i>
May 7	UNH to Help Explore 3 Billion Acres of U.S. Ocean	<i>Foster's Daily Democrat</i>
May 7	UNH Joins Major NOAA Project to Map the Ocean	NHPR
May 7	How Do You Map Three Billion Acres of Ocean?	<i>Concord Monitor</i>
May 9	Gulf Island Shipyards Starts Construction on Rhode Island Research Vessel	<i>Workboat</i>
May 9	UNH to Help Explore 3 Billion Acres of U.S. Ocean	<i>Seacoast Online</i>
May 14	New Technology Searches for Great Lakes Shipwrecks	<i>Iosco County News-Herald</i>
May 18	Exploring the Depths	<i>Alpena News</i>
May 22	Northern Michigan in Focus: B.E.N.	<i>9&amp;10 News</i>
May 30	Like Denmark and Russia, Canada Says Its Extended Continental Shelf Includes the North Pole	<i>Arctic Today</i>
May 30	How Subsea Robots Will Explore Earth's Final Frontier	<i>Daily Beast</i>
May 31	GEBCO-Nippon Foundation Alumni Team Wins Shell Ocean Discovery XPRIZE	<i>Directions Magazine</i>
May 31	UNH Alumni Team Wins XPRIZE	<i>UNH Today</i>
May 31	Teams Autonomously Mapping the Depths Take Home Millions in Ocean Discovery XPRIZE	<i>Tech Crunch</i>
May 31	GEBCO-NF Alumni Robots Win Ocean-Mapping XPRIZE	<i>BBC</i>
Jun. 1	Winner of Shell Ocean Discovery XPRIZE Announced	<i>Maritime Executive</i>
Jun. 1	XPRIZE Selects Winners of Autonomous Seafloor-Mapping Competition	<i>Ars Technica</i>
Jun. 3	Young Talent Flourishes in the Ocean Discovery XPRIZE	<i>Forbes</i>
Jun. 3	Winners Announced in \$7 Million Shell Ocean Discovery XPRIZE for Advancements in Autonomous Ocean Exploration	<i>Aithority</i>
Jun. 3	UNH Alumni Team Wins \$4 Million Grand Prize with Pioneering Technology for Ocean Mapping	<i>NewsWise</i>
Jun. 4	Shell Ocean Discovery XPRIZE Winners Announced	<i>Philanthropy News Digest</i>
Jun. 5	How a Far-Flung Group of Scientists Claimed the Ocean Discovery XPRIZE	<i>Hakai Magazine</i>
Jun. 6	Tech Tidbits From Around NH	<i>NH Business Review</i>
Jun. 7	Underwater Drones Nearly Triple Data from the Ocean Floor	<i>Bloomberg Businessweek</i>
Jun. 8	World Oceans Day 2019: Important Facts about Life Under Water	<i>News 18</i>
Jun. 10	UNH Launches Center on Environmental Acoustics	<i>Seacoast Online</i>
Jun. 10	Acoustics is Topic of New UNH Center	<i>Granite Geek</i>
Jun. 10	UNH Starts Center for Acoustics Research and Education	WCAX
Jun. 10	Robotic Arm Submersible Win XPRIZE for Identifying New Tech for Ocean Floor Mapping	<i>Industry Updates 24</i>
Jun. 10	UNH Launches Center on Environmental Acoustics	<i>Foster's Daily</i>
Jun. 11	Meet the Machines that Could Unlock the Ocean's Deepest Secrets	<i>Popular Mechanics</i>
Jun. 13	Environmental Acoustics Center Launched at UNH	<i>NH Business Review</i>

Jun. 17	A New View	<i>UNH Today</i>
Jun. 19	Coast Survey and CCOM/JHC Lend Expertise to Geoscience Australia	<i>Coast Survey Biweekly Newsletter</i>
Jun. 20	As Countries Battle for Control of North Pole, Science is the Ultimate Winner	<i>Science</i>
Jun. 21	EL-Born Geologist Leads Winning Oceanography Team	<i>Go! &amp; Express</i>
Jun. 22	Mapping the Ocean's Floor, Here and Abroad	<i>Union Leader</i>
Jul. 3	Searching for Shipwrecks in Thunder Bay National Marine Sanctuary	<i>National Marine Sanctuaries News</i>
Jul. 8	Searching for Shipwrecks	<i>Marine Technology</i>
Jul. 16	Will ships without sailors be the future of trade?	<i>BBC</i>
Aug. 5	The Seas Are Alive with the Sound of Methane	<i>Deep Carbon Observatory</i>
Aug. 5	Major Challenges in the Upcoming Polar Expedition	<i>Sveriges Radio</i>
Aug. 7	Greenland Expedition Maps Glacier Water	<i>Kristianstad Bladet</i>
Aug. 13	UNH Robot Ship is Part of Latest Search for Aviation Pioneer Amelia Earhart	<i>Concord Monitor</i>
Aug. 14	UNH Technology Helps Map the Way to Solve Mystery of Pilot Amelia Earhart	<i>EurekAlert!</i>
Aug. 14	Searching for Amelia	<i>UNH Today</i>
Aug. 15	UNH Technology Utilized in Effort to Solve Amelia Earhart Disappearance	<i>NH Business Review</i>
Aug. 16	ASV Joins Search for Aircraft Flown by Amelia Earhart	<i>The Engineer</i>
Aug. 16	ASV Joins Search for Aircraft Flown by Amelia Earhart	<i>Business Telegraph</i>
Aug. 19	Wreckage, Reefs, and Robots: The High-Tech Quest to Find Amelia Earhart's Plane	<i>Digital Trends</i>
Aug. 27	A Northwest Passage Journey Finds Little Ice and Big Changes	<i>Yale Environment 360</i>
Sep. 18	Climate Matters: How New England is Being Impacted by Our Changing Climate	<i>Boston 25 News</i>
Sep. 20	Prime Time	<i>UNH Today</i>
Sep. 20	XPRIZE Winners GEBCO-NF Alumni Meet with Japanese Prime Minister	<i>Hellenic Shipping News</i>
Sep. 27	The Art of Sound	<i>UNH Today</i>
Sep. 30	The Art of Underwater Sound	<i>Granite Geek</i>
Sep. 30	Ocean Discovery XPRIZE Winners Talk Tech in Tokyo with Japanese PM	<i>Hydro International</i>
Oct. 8	Underwater Drones Make Waves	<i>Communications of the ACM</i>
Oct. 14	A Fortuitous Major	<i>UNH Today</i>
Oct. 14	Mapping a New Career	<i>UNH Today</i>
Oct. 21	New High-Resolution Bathymetry Maps Provide a Detailed View of Gulf of Maine Seafloor	<i>Northeast Ocean Data Portal</i>
Oct. 23	14th Annual Distinguished Achievement Awards	<i>URI Today</i>
Nov. 6	Why We Need to Map the Ocean Floor	<i>Nautilus Magazine</i>
Nov. 13	"Patchy" Seascape Emerging: UNH Researchers Explain Why	<i>Foster's Daily</i>
Nov. 13	Climate Change is Even Altering the Vegetation at the Bottom of the Gulf of Maine	<i>Concord Monitor</i>

Nov. 13	Climate Change and Turf Seaweed Causing "Patchy" Seascape	<i>UNH Today</i>
Nov. 14	UNH Researchers Find Climate Change and Turf Seaweed Causing 'Patchy' Seascape	<i>EurekaAlert!</i>
Nov. 16	Kelp, the Forests of the Sea, Vanishing from Southern Maine as Gulf Warms	<i>Portland Press Herald</i>
Nov. 19	Invasive Seaweed is Taking Over the Gulf of Maine, and New Research Says That's Bad News for Fish	<i>Boston Globe</i>
Nov. 21	Topography Sandbox Makes Learning Three-Dimensional	<i>The New Hampshire</i>
Dec. 10	UNH Sails into the Next Generation of Ocean Mapping with NOAA Grant	<i>Newswise</i>
Dec. 10	UNH Sails into the Next Generation of Ocean Mapping with NOAA Grant	<i>EurekaAlert!</i>
Dec. 10	UNH Sails into the Next Generation of Ocean Mapping	<i>UNH Today</i>
Dec. 10	NOAA Office of Ocean Exploration and Research Supports Next Generation of Ocean Mapping	<i>NOAA OER</i>
Dec. 13	UNH Sails into the Next Generation of Ocean Mapping	<i>Foster's Daily Democrat</i>

**Outreach Events**

The facilities at the Center provide wonderful opportunities to engage students and the public in the types of research that we do (Figure 58-1 and 58-2). In 2019, the Center provided individual tours for more than 1000 students and individuals from a number of schools and organizations:

**January–December 2019**

School or Community Group	Number of Students or Participants
Winnisquam High School	10
Civil Engineering College Class	35
UNH Kinesiology Students	20
Hollis Brookline School 7th Grade	230
Rye Jr. High	20
The Community School	10
Somersworth Middle School 6th Grade	105
Holy Trinity School	10
Oyster River Middle School Science Club	15
Barrington 7th Grade	120
Oyster River MS 8th Grade (Spring Class)	90
Paul School	40
Henniker School 8th Grade	35
Portsmouth Naval Shipyard/Innovation Group	5
STEM Librarians Group	35
U.S. Naval Academy Cadet Tour	10
CS 400 Tour	80
Oyster River Middle School (Fall Class)	90
Tour for attendees of GEBCO Meeting	80
<b>Total for 2019</b>	<b>1,253</b>





Figure 58-1. Participants from the GEBCO Map the Gaps conference tour the ASV Lab and the Vis Lab.

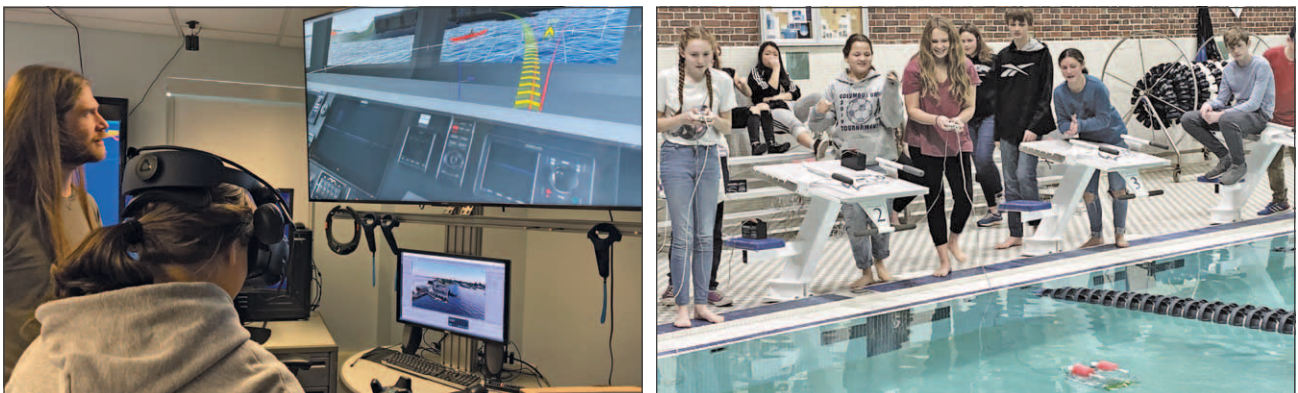

Figure 58-2. Students from Oyster River Middle School toured the CCOM Visualization Lab and tried out the Virtual Reality navigation (left) after testing their SeaPerch ROVs in the UNH Indoor Pool (right).

In addition to these small groups coming to the lab, we host several large and specialized events throughout the year, including SeaPerch ROV events, the annual UNH “Ocean Discovery Day” event, and several workshops for educators. These events attract an additional 3,000 visitors to the Center.

## Ocean Discovery Day

Ocean Discovery Day is an annual two-day event held at the Chase Ocean Engineering Lab. On Friday, October 18th we hosted over 1500 students from school groups and homeschool associations from all over New Hampshire, Maine, and Massachusetts came to visit our facilities and learn about the exciting research happening here at the Center. Activities and demonstrations for all ages highlighted research on telepresence, ocean mapping, Autonomous Surface Vehicles (ASVs), ROVs, ocean engineering, coastal ecology, sounds of the ocean, and ocean visualization. The event was also open to the public on Saturday, October 19th, when 800 more children and adults came to learn about the exciting research at the Center (Figure 58-3).

Students and the public were able to tour our engineering tanks in our High Bay, see video taken on the sea floor in our Telepresence room, and try

their hand at mapping the ocean floor. They could see the Zego boat and jet-ski that we use to map shallow coastal areas, learn how we will be using our ASVs for ocean research, see how scientists explore the ocean using sound waves, and test drive SeaPerch ROVs. Our visualization team showed off their interactive weather map and ocean visualization tools.

Our new tradition for the Saturday event is a scavenger hunt, which when completed earned all kids who participated an Ocean Discovery Day patch.

Ocean Discovery Day is a joint outreach event run through the Center, the UNH Marine Program, the New Hampshire Sea Grant office, and the School of Marine Science and Ocean Engineering. It relies on faculty, staff, and student volunteers from UNH, and volunteers from UNH Marine Docent program.





Figure 58-3. Scenes from Ocean Discovery Day.

### SeaPerch ROV

For a number of years, the Center has worked with the Portsmouth Naval Shipyard (PNS) and the UNH Cooperative Extension to train and host participating schools, after school programs, and community groups who have built SeaPerch Remotely Operated Vehicles (ROVs) and wish to test them out in our facilities. Local schools have brought their students to the Center to test drive ROVs in our engineering tank and tour both our Center and the engineering

facilities on campus. The interest in these ROVs was so great that PNS and the Center started the Seacoast SeaPerch Regional Competition in 2012. We have continued to host SeaPerch builds and provide facilities to support participating student groups throughout this year. This year we held our first Educator workshop at UNH Manchester in August, and then followed up with another Educator workshop in Durham in November (Figure 58-4).





Figure 58-4. Educators building SeaPerch ROVs during one of our Educator Training Workshops.

The SeaPerch program culminates each year in a series of regional, then national competitions for the student groups. The Center, in conjunction with PNS and the UNH Cooperative Extension Program, host the local Seacoast SeaPerch Competition. The seventh annual event was held on Friday, April 5th, 2019 on the UNH campus (Figure 58-5). Fifty teams from New Hampshire, Maine, and Massachusetts schools,

afterschool programs, and community groups competed in this challenge, using ROVs that they built themselves. A SeaPerch is an underwater ROV made from simple materials such as PVC pipe, electric motors, and simple switches. While there is a basic SeaPerch ROV design, the children have the freedom to innovate and create new designs that might be better suited for their specific challenge. This year's

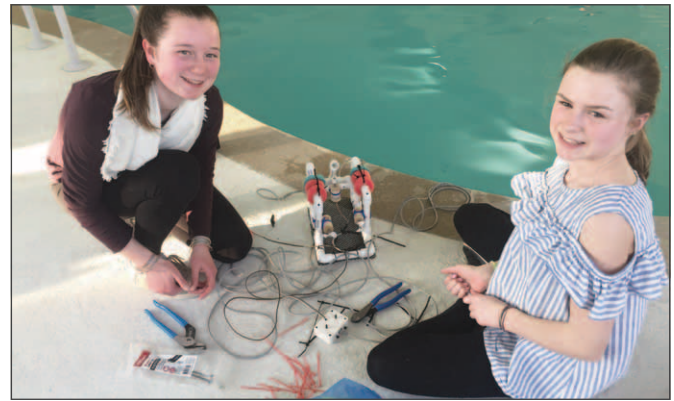
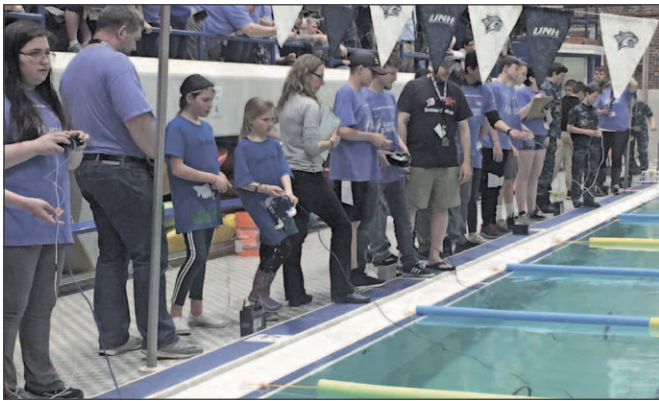

Figure 58-5. Scenes from the 2019 SeaPerch season.





Figure 58-6. SeaPerch tank at the UNH STEM Day at the UNH Football game.

competition included challenges such as an obstacle course where pilots had to navigate their ROV through five submerged hoops, and a Challenge Course modeled after the Thailand cave rescue, where the ROV had to maneuver through hoops to deliver supplies and collect ROV parts. Ed Cormier, the engineering recruiter and STEM outreach coordinator at the Shipyard, said SeaPerch yields big benefits for students throughout the region. “They’re learning technical reading and writing skills, learning the engineering thought process. It’s a great program that schools and 4-H and other programs can get into for a low cost, but that also hits major points in the STEM pipeline. It’s great not just for engineering students, but students who are going into trades, as well.” All teams participated in a poster competition where they talked about their design choices, the costs involved in their modifications, and how they worked as a team.

This year’s winning teams represented the Seacoast at the SeaPerch Finals in College Park, Maryland, which was a wonderful opportunity for our local students to experience competition on a higher level. One of our high school teams came first place for the High School division, and a second high school team came in third for the Mission Course. We are proud of how well our local teams do on this national stage!

Hicks Johnson has also been in discussions with the Robonation program that runs the National Competition about UNH hosting the Nationals. As this is a new group to organize the program, we hope that they will visit UNH to see our facilities soon.

**Other Activities**

In addition to the major outreach events that we manage each year, we also participate in smaller events and support smaller groups. For example:

- UNH was host to the National Marine Educators Association Annual Conference in July. Over 350 formal and informal marine educators from K-12 schools, public aquariums, non-profit NGOs, and government agencies came together for four days of learning, sharing, and networking. The Center was a lead sponsor for this conference and served as a meeting location for many of the pre-conference meetings.
- The Center participated in the UDay Celebration in the fall of 2019—a celebration of UNH clubs, departments and activities.



Figure 58-7. SeaPerch testing with some students in the UNH Manchester EXCELL in STEM after school program.



Figure 58-8. UNH Alumni and AGU Fellow Peggy Shea tests the VR Demonstration with the help of Ph.D. student Drew Stevens at the 2019 American Geophysical Union Fall Meeting.



Figure 58-9. The Center's booth at the U.S. Hydro Conference in March.



Figure 58-10. The Center's booth at the NH Science Teachers Association Annual Meeting

- The Center participated in STEM Day at UNH Football by having a SeaPerch ROV tank and information about the Outreach and Academic programs available at the Center (Figure 58-6).
- The Center assisted in the pool testing of SeaPerch ROVs for UNH Manchester STEM Lab program called EXCELL in STEM. This program combines pre-college English language learners and hands-on activities science, engineering, and computing (Figure 58-7).
- Outreach activities and Center programs were also highlighted at the NH Science Teachers Association Annual Meeting (Figure 58-10), the National Science Teachers Association Annual Meeting, and the American Geophysical Union Fall Meeting in San Francisco.



Figure 58-11. Designs for the new outreach banners.



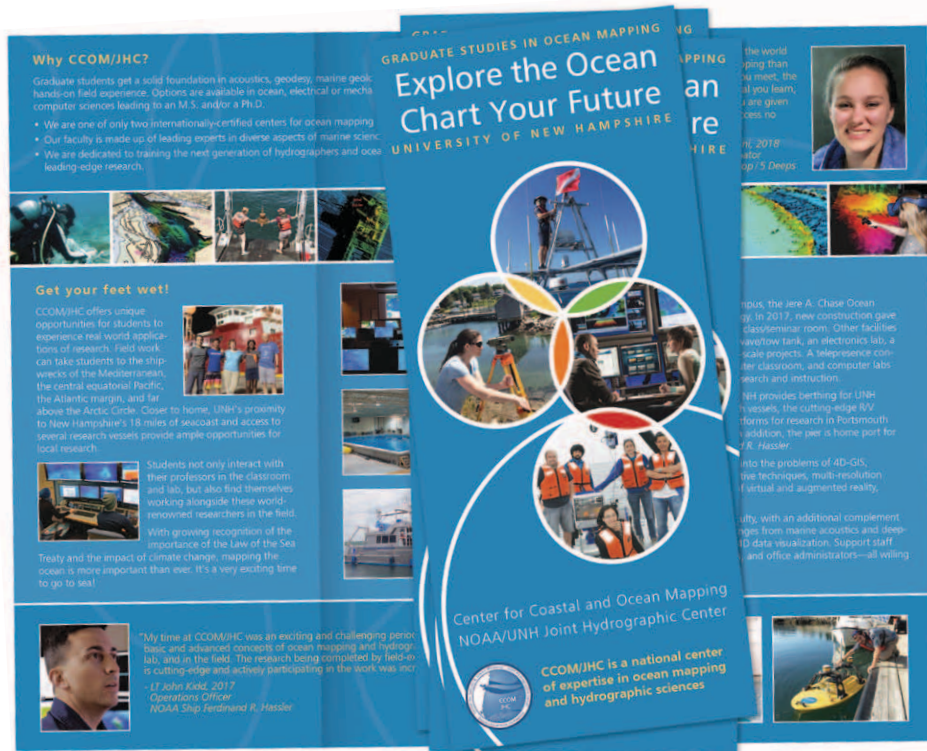

Figure 58-12. The Center’s new education brochure.

**Updated Outreach Materials**

The Center’s outreach booth has been updated with new banners and a matching tablecloth (Figures 59-8, 58-10, and 58-11). The education brochure was updated to coordinate with the new theme (Figure

58-12). We also created a new giveaway in the form of a pop-up phone grip that features bathymetry from Necker Ridge (Figure 58-13).

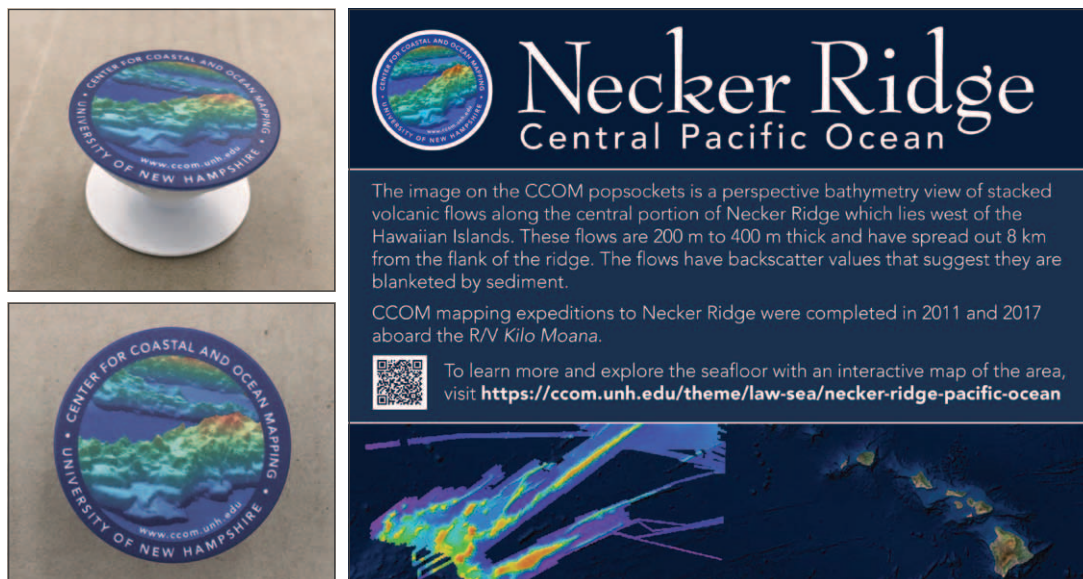

Figure 58-13. The Center’s pop-up phone grip giveaway (left). Display sign with information about the bathymetric image featured on the pop-up phone grip.



## Website and Other Digital Media

While the Center is dedicated to finding opportunities to expose local and regional young people to ocean science and engineering, we are also committed (and very excited!) to engage with our constituents around the world. With today's social media platforms and digital media, we have built a community with our industrial partners, our alumni, our ocean-going cohorts, and people working in ocean sciences in other countries.

### Website

The JHC/CCOM website, ([www.ccom.unh.edu](http://www.ccom.unh.edu)) is the public face of the Center ((Figure 58-15). The website is a vast repository of information about the Center's research, education programs, outreach, and facilities. Not only is it regularly updated with new information, but it holds the history of the Center in its publications catalog, news archive, media resources, and progress reports.

The management of the website requires constant attention. Will Fessenden facilitates the backend—installing updates, troubleshooting problems, and assuring that the site is smoothly served up to the internet. Colleen Mitchell manages the content—overseeing publications, writing briefs and articles, and creating web-optimized images that serve to enhance and illuminate the Center's work. The homepage is frequently updated with announce-

ments, publications, images, and videos. Thirty-two front page slides were featured in 2019, highlighting awards and honors, interviews, news articles, and outreach events.

The website received 122,537 page views from 32,380 unique visitors in 2019. The average visit lasted 2 minutes and 53 seconds with an average of 2.5 pages visited. The U.S. is the origin of 63% of visits, while the rest are spread all over the globe. We had visits from 191 countries outside the U.S., including such exotic locales as Montenegro, Yemen, and Palau. In fact, nearly every ocean state in the world has accessed the Center's website. A new plot offered by Google Analytics that illustrates web access by city shows that people from 4,982 cities around the world have visited our website. Hovering over the marked cities reveals the exact number of visitors, such as

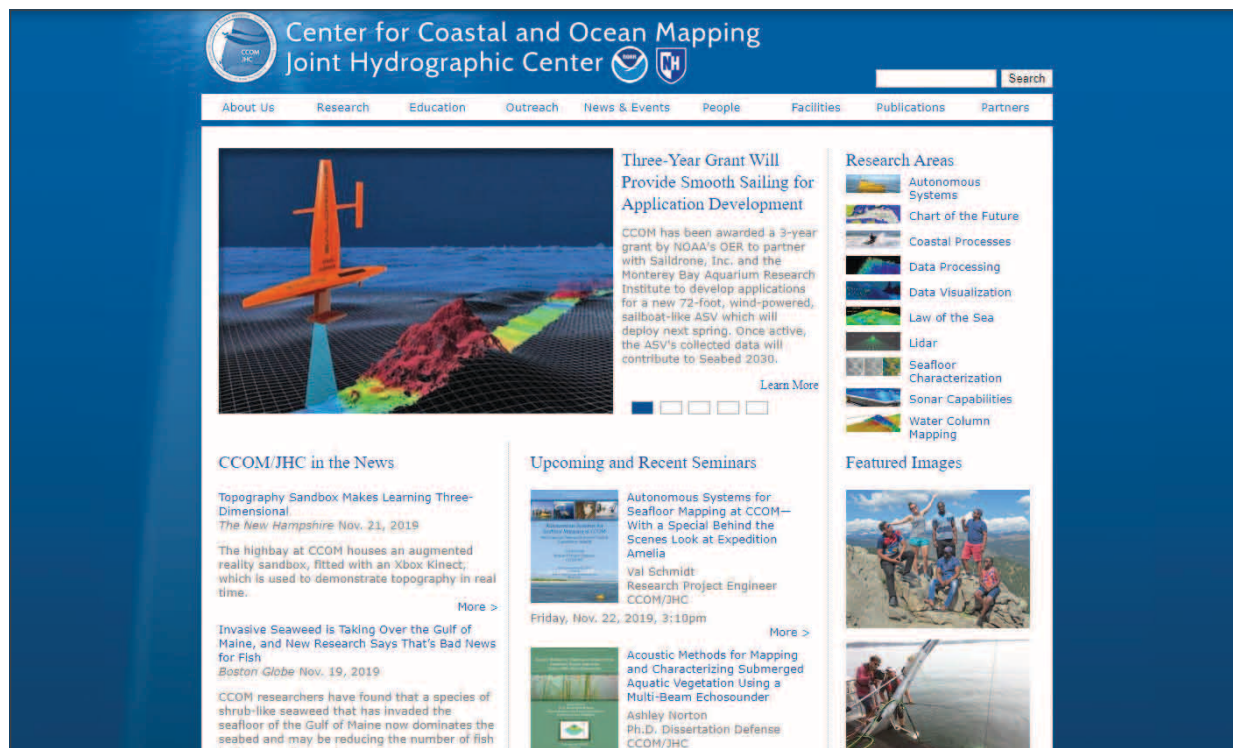

Figure 58-15. The homepage of the Center's website.

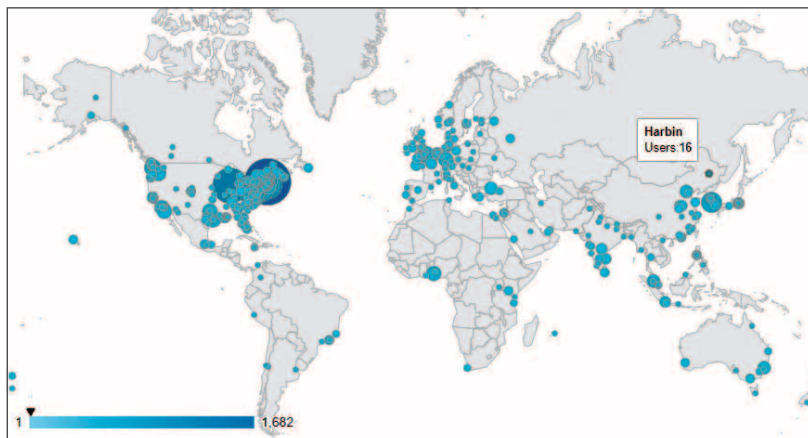

Figure 58-16. Google Analytics plot of Center website visitors by city.

Page	Pageviews	% Pageviews
1. /	16,740	13.66%
2. /people	8,048	6.57%
3. /project/jeffreys-ledge	5,137	4.19%
4. /about-ccomjhc	2,425	1.98%
5. /research	2,166	1.77%
6. /education	1,751	1.43%
7. /theme/lidar	1,730	1.41%
8. /gebco	1,394	1.14%

Figure 58-17. Google Analytics chart of Center website visitors' destinations.

the sixteen users in Harbin, China—a gain of 10 users since our last reporting period—or the 1,199 users in Chicago, Illinois (Figure 58-16).

We cannot explain our popularity in Harbin but we posit that the nearly doubling of visits from Chicago is a reflection of our ASV team's work with NOAA's Thunder Bay National Marine Sanctuary in Lake Huron last spring.

A report on page views shows that our homepage is the most popular landing page, followed by the People directory page, the Jeffreys Ledge project page, the About Us page, etc. (Figure 58-17).

### Facebook

The Center's Facebook page, ([www.facebook.com/ccomjhc](http://www.facebook.com/ccomjhc)), currently has 1,612 followers.



Figure 58-18. The Center's Facebook page.

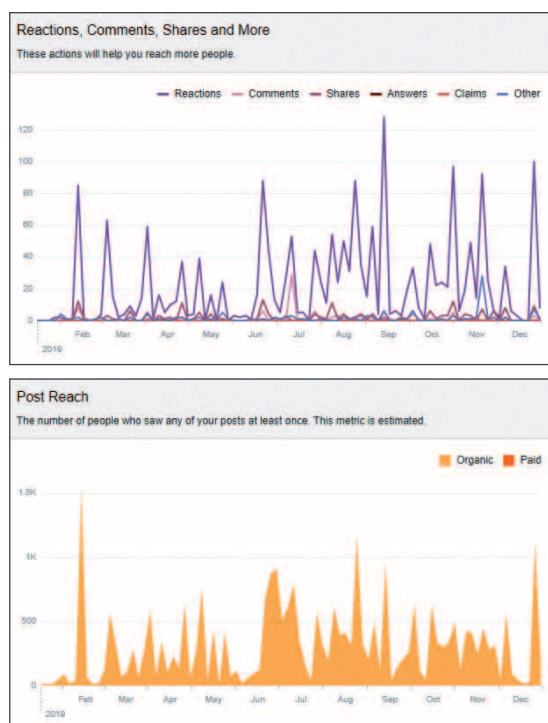

Figure 58-19. Charts showing the Center's Facebook post reactions, comments, and shares (top) and the "reach" of posts (bottom) for 2019.



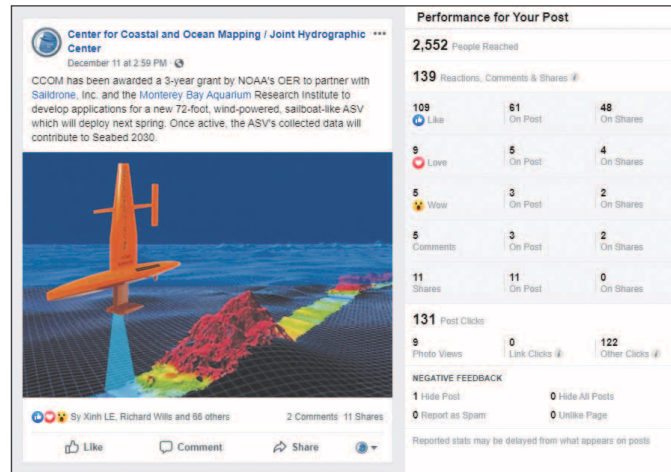
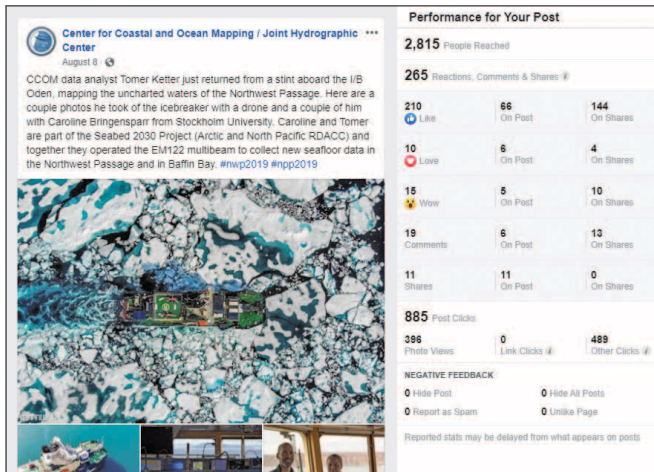

Figure 58-20. The two posts with the most exposure in 2019.

Although Facebook’s analysis algorithms continue to be fairly opaque, their statistics page does allow us to observe likes, “reach,” and the popularity of individual posts (Figure 58-19).

The most popular post this year was on August 8th when we posted about data analyst Tomer Ketter’s cruise aboard the I/B *Oden* (Figure 58-20). The post

reached 2,815 people and was liked and shared numerous times. Ketter’s spectacular drone photos were no doubt part of the draw, proving once again how important visuals are in communications.

The second most popular post (Figure 58-20) was the December 11 announcement that the Center has been awarded a three-year grant to partner with Saildrone and the Monterey Bay Aquarium Research Institute to develop applications for a new ASV. The post reached an audience of 2,552 and was also liked and shared many times.

## Flickr

There are currently 2,621 images and videos in the Center’s Flickr photostream ([www.flickr.com/photos/ccom\\_jhc](http://www.flickr.com/photos/ccom_jhc)) (Figure 58-21).

## Vimeo

The Center’s videos are hosted by Vimeo ([vimeo.com/ccomjhc](http://vimeo.com/ccomjhc)). There are currently 135 videos in the Center’s catalog (Figure 58-22). Since the Vimeo site was created, our videos have been viewed 50,000 times. In 2019, the Center’s videos were played 4,627 times. While the U.S. is the origin of most plays, Center videos have been viewed all over the world (Figure 58-23).

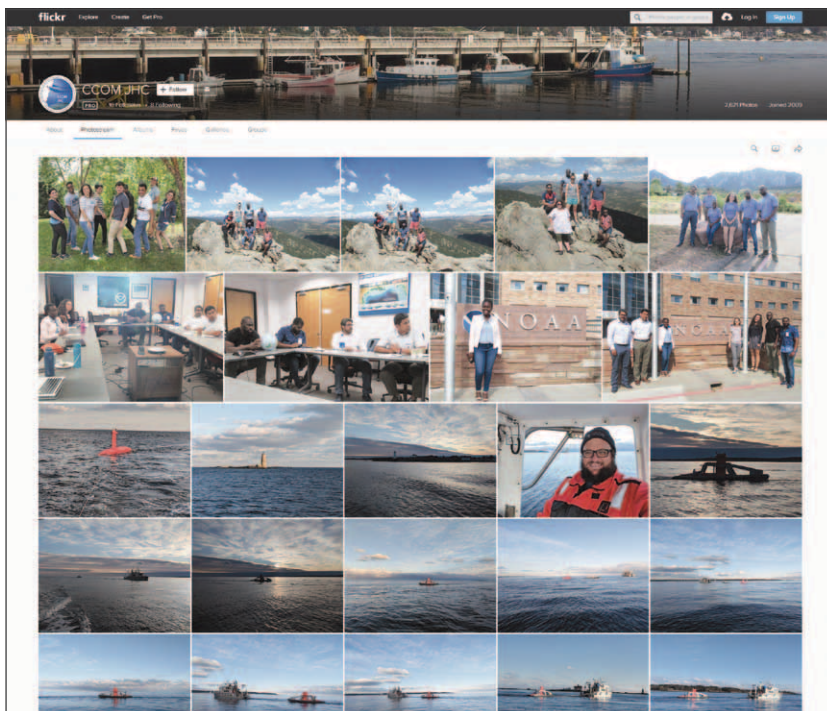

Figure 58-21. The Center’s Flickr photostream.



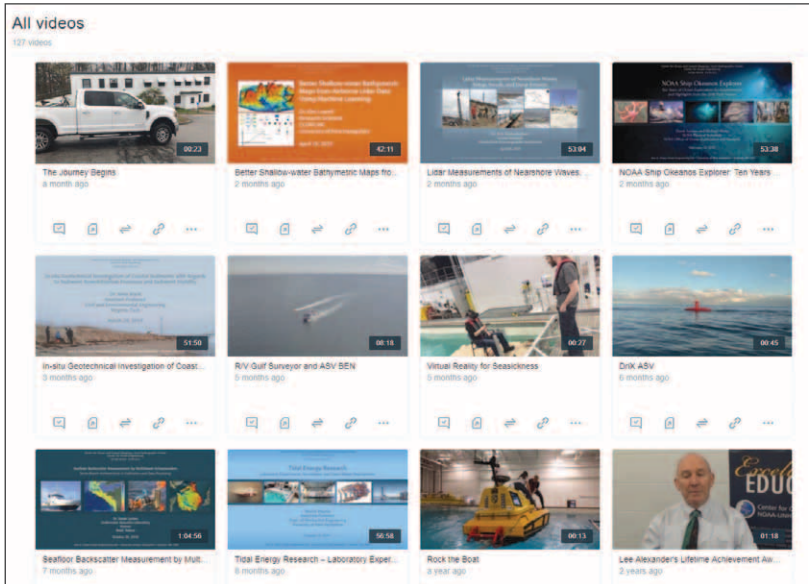

Figure 58-22. A sampling of the videos available in the Center’s Vimeo catalog.



Figure 58-23. Vimeo’s statistics showing the number of videos played in 2019 by Region.

**Seminar Series**

This year, the joint Center/Ocean Engineering seminar series featured 30 seminars (Figure 58-24). Three of these seminars were master’s thesis defenses; three were doctoral dissertation defenses, and one was a doctoral dissertation proposal defense. The rest were given by Center researchers or experts from

industry and academia. CCOM graduate students Josh Humberston and Lynette Davis were the Center’s seminar coordinators for the spring 2019 semester. CCOM Ph.D. student Anne Hartwell and OE Ph.D. student Allisa Dalpe took over coordinating duties for the fall 2019 semester.

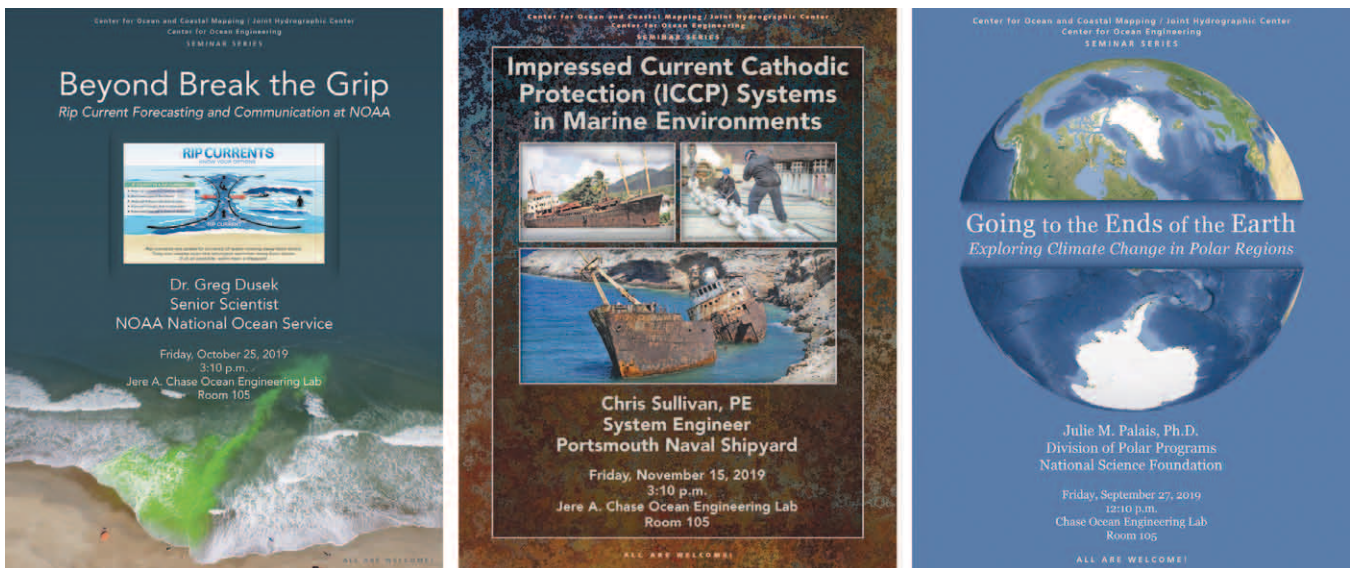

Figure 58-24. A few of the 30 flyers produced for the 2019 Seminar Series.

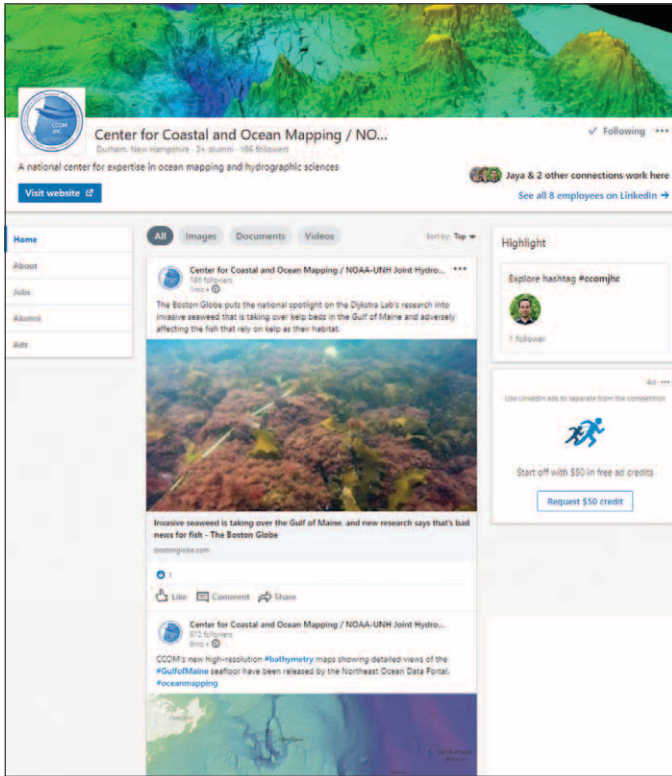

Figure 58-25. The Center's LinkedIn feed.

## LinkedIn

As an avid user of LinkedIn, Research Assistant Professor Giuseppe Masetti felt that the Center's lack of presence on the site was a missed opportunity. He created a page for the Center ([linkedin.com/school/ccomjhc](https://www.linkedin.com/school/ccomjhc)) and Colleen Mitchell has begun posting to its feed (Figure 58-25). Our hope is that we will reach people who do not necessarily interact with other social media, such as Facebook and Twitter.

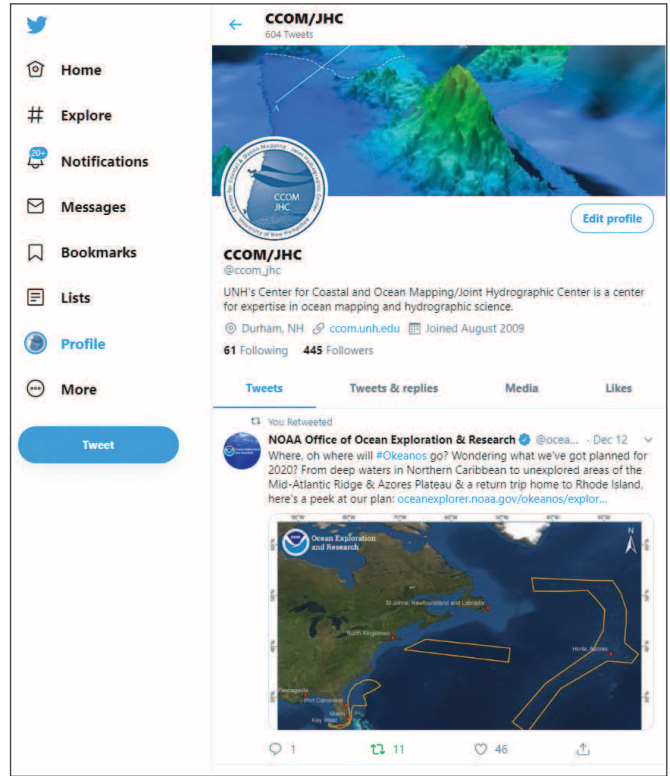

Figure 58-26. The Center's Twitter page.

## Twitter

The Center's Twitter feed (Figure 58-26) provides opportunities to interact with other members of the hydrographic community. To date, the Center has tweeted 604 times ([twitter.com/ccom\\_jhc](https://twitter.com/ccom_jhc)). We are now following 61 groups or individuals in the ocean community, while 445 people or groups follow us.

## Data Management

**TASK 59: Data Sharing ISO19115 Metadata: Transition from the FGDC format to the ISO 19115 format.**

PI: **Paul Johnson**

JHC Participants: Paul Johnson and Jordan Chadwick

The U.S. government has been encouraging researchers and groups who collect and distribute data to transition from the FGDC Content Standard for Digital Geospatial Metadata (CSDGM) format to the ISO 19115-02 metadata format. The Center had already developed robust scripts used to data mine content out of raw data files, such as Kongsberg .all files, and to transform this information into well-formed and validated FGDC metadata. We have created a series of Python scripts to produce ISO19115-02 metadata records from our raw data files, though the approach

is not as efficient as it can be. Following on from this, as part of the DOI discussions with NCEI (see Task 47) regarding ECS data, NCEI has agreed to help us work on a proper crosswalk from our raw harvested file information to the ISO format but we are still waiting for input from NCEI. This past summer, we finalized our Extended Continental Shelf ISO19115-2 metadata standard and delivered all of the final bathymetry and backscatter grids to the ECS program office with validated ISO19115 metadata.

**TASK 60: Enhanced Web Services for Data Management: Build upon state-of-the-art web services for the management and distribution of complex data sets.** PI: **Paul Johnson**

Project: **Enhanced Web Services for Data Management**

JHC Participants: Paul Johnson, Tomer Ketter, and IT Staff

### GIS Server and Portal

The center's online GIS presence, available at <https://maps.ccom.unh.edu> (Figure 60-1), has been up and running with the current version of ESRI's Enterprise Server, Portal, and Datastore software since the late fall of 2018. While a small set of interactive web services were created and published following the initial deployment of

the server, the full capabilities of the server were not truly utilized until the spring of 2019, when Johnson started the process of transitioning the method of publishing the web services from the long-used ESRI ArcGIS Desktop software to the more modern ESRI ArcGIS Pro software.



Figure 60-1. Home page of the Center's GIS portal (<https://maps.ccom.unh.edu/arcgis/home/>).

By publishing services through ArcGIS Pro to the up-dated enterprise online GIS solution, many useful features, abilities, and visualization options were made available. To showcase some of these abilities, Johnson published the Center's Western Gulf of Maine bathymetric synthesis (which is currently in the process of being recompiled to include southern and northern New England) and the GEBCO 2019 bathymetric grid through the Portal. Both of these web services utilize new visualization and interactive features including: color palettes based on the dynamic range of the data visible on the screen (Figure 60-2), real time calculation of single and multi-directional hillshades (side lighting), real time calculation of bathymetric



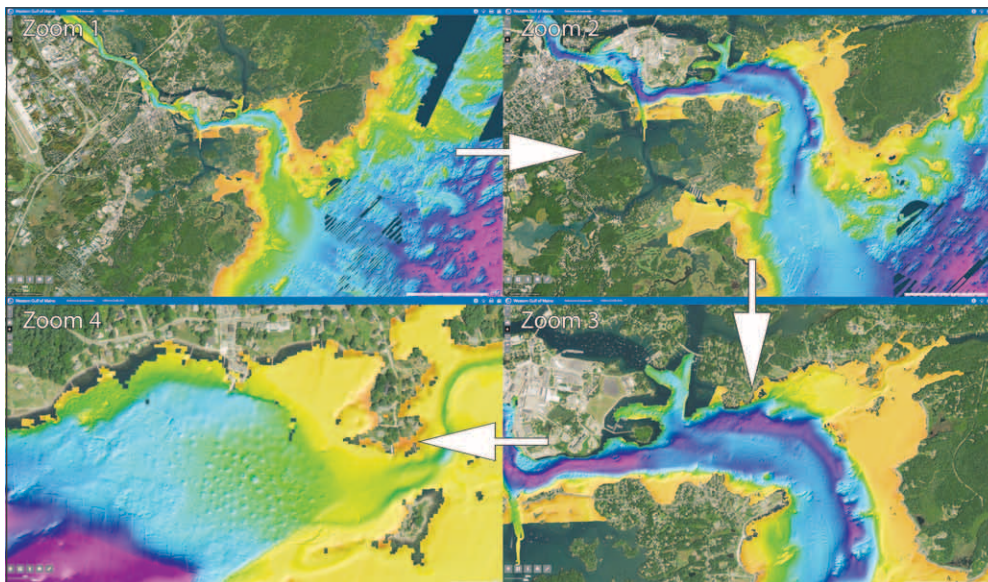

Figure 60-2. Example of a dynamically adjusting color palette based on the range of depth values visible on the screen. This example use the Western Gulf of Maine bathymetry synthesis. (<https://maps.com.unh.edu/portal/apps/webappviewer/index.html?id=be8b9f48f19b485b8fc75d584a05bfaf>).

contours, enhanced raster and vector query of objects in web maps and scenes, and visualization of large scale datasets on globes (Figure 60-3).

With these new visualization features available, Johnson began implementing them into the Center's Extended Continental Shelf web services, during

development of new versions of the Marianas Region datasets. During the spring of 2019, Gardner and Johnson constructed new grids of backscatter, primary ECS bathymetry (Figure 60-4), regional bathymetry, and regional bathymetry merged with data from the GEBCO 2019 grid. As part of the process of developing these new data products, rigorous assessment was required on all data prior to release. The ability to overlay developmental datasets on top of each other, adjust color palettes, set transparency of layers (Figure 60-5), query depths, and inspect contributing layers through the online GIS made this process quite painless.

The upgrade to the server and portal also facilitated the creation of some new tools aimed at easing the process of selecting appropriate multibeam calibration and system testing sites. This toolkit, which is also discussed as part of Task 8, utilizes large area bathymetric grids such as the Center's Atlantic Margin extended continental shelf grid and the University of Hawaii's Main Hawaiian Islands synthesis (<http://www.soest.hawaii.edu/HMRG/multi-beam>) to identify possible testing locations by calculating depth ranges optimized for shallow water MBES (70-100 kHz), medium (30 kHz), and deep (12 kHz) systems defined by swath performance curves; and within each of these depth ranges classify the seafloor with proper slopes for pitch and heading lines (15°–30°

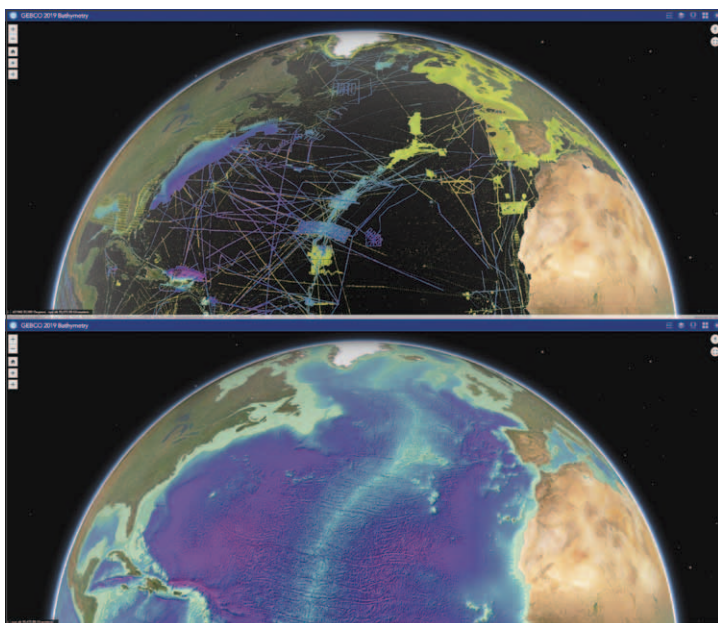

Figure 60-3. Globe visualization of the GEBCO 2019 bathymetry grid (<http://bit.ly/2sMMw2R>). The bottom half of the figure shows the GEBCO 2019 bathymetry grid. Top half of the figure shows the same grid with areas containing interpolated values set to black and areas composed of pre-generated grids as yellow.



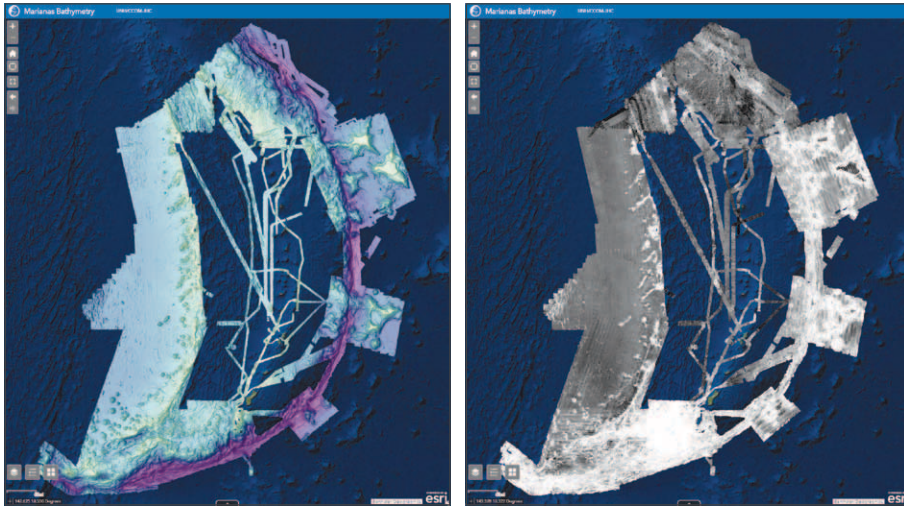

Figure 60-4. New primary bathymetry and backscatter syntheses for the Marianas region (see <http://bit.ly/2Z7YboZ>).

slopes) and roll and accuracy lines ( $0^{\circ}$ – $2^{\circ}$  slopes). Web applications showing the results of this seafloor classification are either available through the Center’s GIS portal interface at <https://maps.ccom.unh.edu> or directly through <http://bit.ly/2qx4oxU> for the Atlantic Site and <http://bit.ly/2OUFm59> for the Hawaii site.

Figure 60-6 shows the bathymetric data (upper left) and the slope (bottom left) which are used by the server to classify the seafloor for different test and calibration types. In the bottom right figure, the areas

shown in the red to orange colors indicate seafloor suitable for pitch and heading calibration with the different shades differentiating different depth zones (dark red is deep, orange is medium, and light orange is shallow). The blue gradational colors show seafloor suitable for roll and accuracy lines with the different shades of blue distinguishing the different depth zones (dark blue is deep, blue is medium, and light blue is shallow). This information along with the ability to show historically used test sites, display auxiliary information such as vessel traffic and water complexity models, and the ability to provide easily editable annotations and features, including point, lines, and polygons features (see Figure 60-7), through the newly installed online database have made the entire test site selection much easier. Over the next year we will be adding more historic calibration and testing sites used by NOAA and other ship operators, as well as integrating worldwide bathymetric datasets to expand our global coverage, and the Center will also be adding in shallow water bathymetric datasets to allow for the calculation of very-shallow test sites.

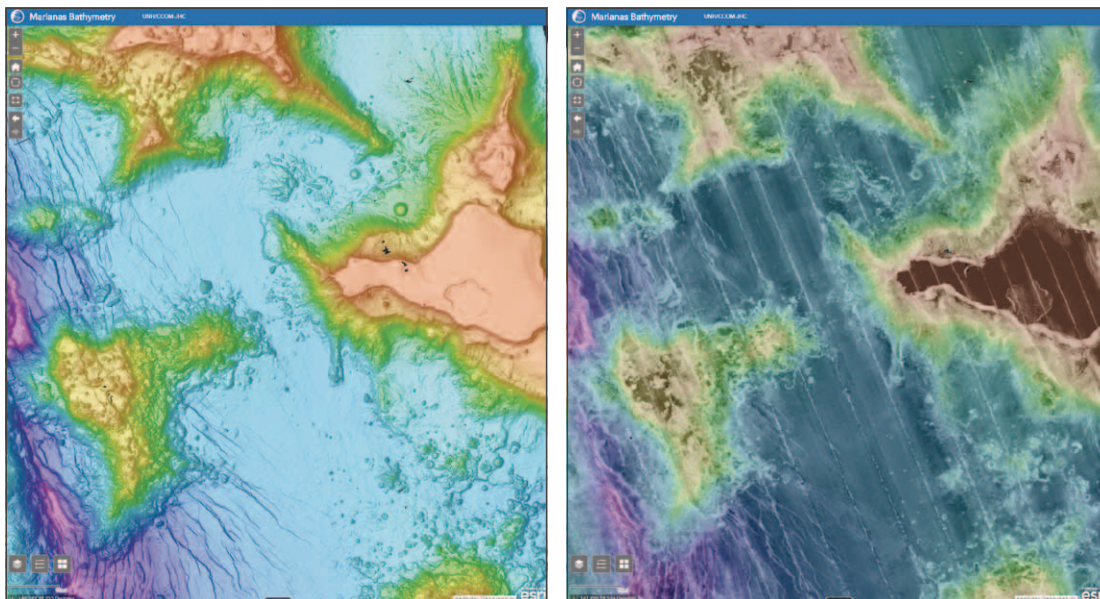

Figure 60-5. Left: A new webservice of the Marianas bathymetry utilizing dynamically adjusted range color palettes with real-time calculated multi-directional hillshade. Right: Semi-transparent dynamically adjusted range backscatter overlaid on side-lit bathymetry. Webservice is available at <http://bit.ly/2Z7YboZ>.



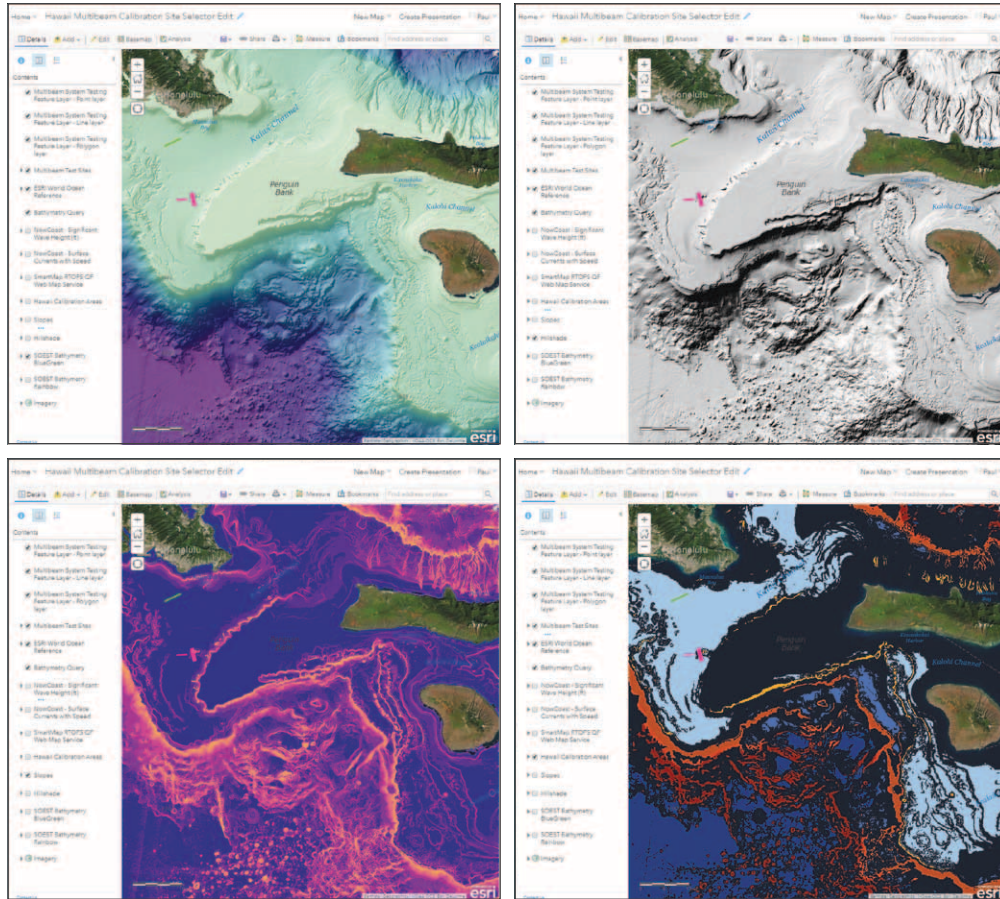

Figure 60-6. A new webservice utilizing the University of Hawaii’s Main Hawaiian Island bathymetric synthesis (<http://www.soest.hawaii.edu/HMRG/multibeam>) to identify potential sites for calibration and system testing. Top-Left figure shows the shaded relief bathymetry as well as showing historical test sites (green and magenta lines), Top-Right shows the hillshade of the same scene, Bottom-Left shows the calculated slopes, and Bottom-Right shows areas identified as having proper slope and depths for either pitch/heading calibration (red to orange areas) or roll/accuracy (gradational blue areas).

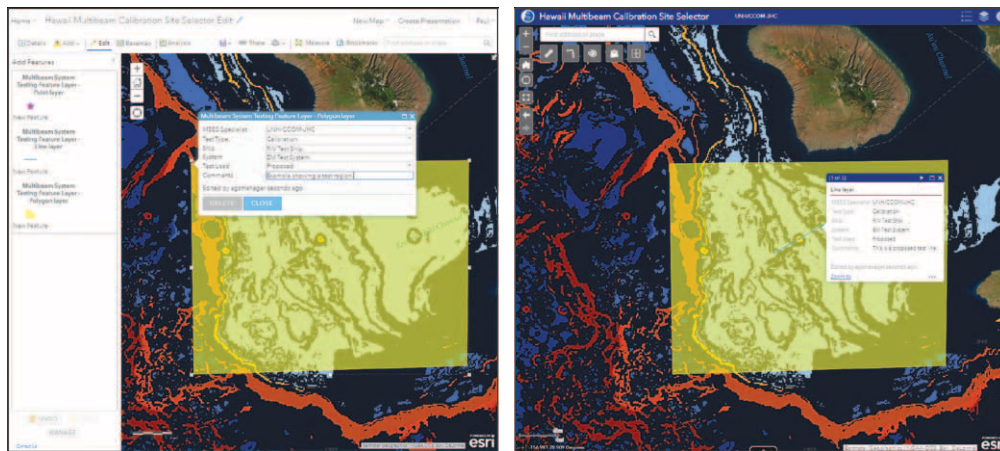

Figure 60-7. Left shows the center’s private internal interface to the web service which allows the creation of point feature, line features, and polygon features to indicate areas suitable for testing and to share line plans. These features can then be shared through the publicly available web app for ships and other users to interact with.



## Appendix A: Graduate Degrees in Ocean Mapping

The University of New Hampshire offers Ocean Mapping options leading to Master of Science and Doctor of Philosophy degrees in Ocean Engineering and in Earth Sciences. These interdisciplinary degree programs are provided through the Center and the respective academic departments of the College of Engineering and Physical Sciences. The University has been awarded recognition as a Category "A" hydrographic education program by the International Federation of Surveyors (FIG)/International Hydrographic Organization (IHO)/International Cartographic Association (ICA). Requirements for the Ph.D. in Earth Sciences and Engineering are described in the respective sections of the UNH Graduate School catalog. M.S. degree requirements are described below.

Course	MSOE Thesis	MSES Thesis	MSES Non-Thesis	Certificate
Integrated Seabed Mapping Systems (OM I)	✓	✓	✓	✓
Advanced Topics in Ocean Mapping (OM II)	✓	✓	✓	✓
Geodesy and Positioning for Ocean Mapping	✓	✓	✓	✓
Hydrographic Field Course	✓	✓	✓	✓
Geological Oceanography		✓	✓	
Introductory Physical Oceanography		✓	✓	
Ocean Measurements Lab	✓			
Ocean Engineering Seminar I	✓			
Ocean Engineering Seminar II	✓			
Underwater Acoustics	✓			
Mathematics for Geodesy		✓	✓	✓
Research Tools for Ocean Mapping		✓	✓	✓
Seminar in Earth Sciences		✓	✓	✓
Proposal Development		✓	✓	
Seamanship	✓	✓	✓	✓
Physical Oceanography for Hydrographic Surveyors	✓			✓
Geological Oceanography for Hydrographic Surveyors	✓			✓
Approved Elective Credits	+6		+4	
Directed Research Project			✓	
Thesis	✓	✓		
<b>3rd Party Training</b>				
QPS (QIMERa, FMGT, Fledermaus)	✓	✓	✓	✓
ESRI (ArcGIS)	✓	✓	✓	✓
Caris (HIPS/SIPS)	✓	✓	✓	✓
HYPACK (Hysweep)	✓	✓	✓	✓

MSOE: Master of Science in Ocean Engineering with Ocean Mapping option – includes thesis

MSES: Master of Science in Earth Sciences with Ocean Mapping option – includes thesis

MSES non-thesis: Master of Science in Earth Sciences with Ocean Mapping option – non-thesis

Certificate: Graduate Certificate in Ocean Mapping – non-thesis

Table A.1 The Ocean Mapping (OM) graduate curriculums offered through the Center. Black tick marks indicate the courses required for the various degrees. The red tick marks indicate the additional training required to meet Category A requirements.

## Master of Science in Ocean Engineering

### Ocean Mapping Option

Core Requirements		Instructor	Credit Hours
OE 810	Ocean Measurements Lab	Lippmann	4
OE 874	Integrated Seabed Mapping Systems	Dijkstra/Hughes Clarke/Calder	4
OE/ESCI 875	Fundamentals of Ocean Mapping II	Dijkstra/Mayer/Armstrong	4
OE 871	Geodesy and Positioning for Ocean Mapping	Dijkstra	3
OE 865	Underwater Acoustics	Weber	3
OE 972	Hydrographic Field Course	Dijkstra	4
OE 990	Ocean Engineering Seminar I	Mayer	1
OE 991	Ocean Engineering Seminar II	Mayer	1
OE 899	Thesis		6

#### At Least Three Additional Credits from the Electives Below

OE 854	Ocean Waves and Tides	Swift	4
OE 857	Coastal Engineering and Processes	Foster	3
OE 864	Spectral Analysis of Geophysical Time Series Data	Lippmann	3
OE 895	Special Topics	Staff	1-4
ECE 814	Introduction to Digital Signal Processing	Smith	4
ESCI 858	Introduction to Physical Oceanography	Pringle	3
ESCI 896.02	Special Topics	Staff	1-4

Where a course of equivalent content has been successfully completed as an undergraduate, an approved elective may be substituted.

## Master of Science in Earth Sciences

### Ocean Mapping Option

Core Requirements		Instructor	Credit Hours
ESCI 858	Introductory Physical Oceanography	Pringle	3
OE 859	Geological Oceanography	Johnson	4
OE 871	Geodesy and Positioning for Ocean Mapping	Dijkstra	3
OE 872	Applied Tools for Ocean Mapping	Dijkstra	2
OE 874	Integrated Seabed Mapping Systems	Dijkstra/Hughes Clarke/Calder	4
OE 875	Advanced Topics in Ocean Mapping	Dijkstra	4
OE 972	Hydrographic Field Course	Dijkstra	4
MATH 831	Mathematics for Geodesy	Wineberg	3
ESCI 997	Seminar in Earth Sciences	Hughes Clarke	1
ESCI 998	Proposal Development	Palace	1
ESCI 899	Master's Thesis		1-6

Additional elective courses must be taken to meet graduate credit requirements (with approval).

## Master of Science in Earth Sciences (Non-Thesis Option)

### Ocean Mapping Option

Core Requirements		Instructor	Credit Hours
ESCI 858	Introductory Physical Oceanography	Pringle	3
OE 859	Geological Oceanography	Johnson	4
OE 871	Geodesy and Positioning for Ocean Mapping	Dijkstra	3
OE 872	Applied Tools for Ocean Mapping	Dijkstra	2
OE 874	Integrated Seabed Mapping Systems	Dijkstra/Hughes Clarke/Calder	4
OE 875	Advanced Topics in Ocean Mapping	Dijkstra	4
OE 972	Hydrographic Field Course	Dijkstra	4
MATH 831	Mathematics for Geodesy	Wineberg	3
ESCI 997	Seminar in Earth Sciences	Hughes Clarke	1
ESCI 998	Proposal Development	Palace	1
ESCI 898	Directed Research		2

Additional elective courses must be taken to meet graduate credit requirements (with approval).

Where a course of equivalent content has been successfully completed as an undergraduate, an approved elective may be substituted.

## Graduate Certificate in Ocean Mapping

Core Requirements		Instructor	Credit Hours
OE 871	Geodesy and Positioning for Ocean Mapping	Dijkstra	3
OE 872	Applied Tools for Ocean Mapping	Dijkstra	2
MATH 831	Mathematics for Geodesy	Wineberg	3
OE 874	Integrated Seabed Mapping Systems	Dijkstra/Hughes Clarke/Calder	4
OE 875	Advanced Topics in Ocean Mapping	Dijkstra	4
OE 972	Hydrographic Field Course	Dijkstra	4
OE 677	Seamanship and Marine Weather	Armstrong	2
ESCI 896.2	Physical Oceanography for Hydrographers	Hughes Clarke	2
ESCI 896.4	Geological Oceanography for Hydrographers	Hughes Clarke/Wigley/Ward	2

Additional elective courses must be taken to meet graduate credit requirements (with approval).

Where a course of equivalent content has been successfully completed as an undergraduate, an approved elective may be substituted.



## Academic Year 2019 Graduate Students

Student	Program	Advisor/Mentor
Leo Araujo	M.S. ES Ocean Mapping	B. Calder
Ivan Bodra Guimaraes	M.S. ES Ocean Mapping	J. Hughes Clarke
Alex Brown *	M.S. Computer Science	B. Calder (Schmidt)
Jangeun Choi	Ph.D. OE	T. Lippmann
Salme Cook	Ph.D. Oceanography (rec'd 2019)	T. Lippmann
Lynette Davis *	M.S. OE Ocean Mapping	B. Calder (Schmidt)
Gregory Deemer	Ph.D. OE	A. Lyons
Massimo Di Stefano *	Ph.D. ES Oceanography	L. Mayer
Jeffrey Douglas (NOAA)	M.S. OE Ocean Mapping	A. Armstrong
Jonathan Hamel *	M.S. OE Ocean mapping	T. Weber
Anne Hartwell	Ph.D. Oceanography	J. Dijkstra
Erin Heffron *	M.S. ES Ocean Mapping	L. Mayer
Shannon Hoy (NOAA) * ~	M.S. ES Ocean Mapping	B. Calder
Josh Humberston	Ph.D. ES Oceanography	T. Lippmann
Jennifer Johnson *	M.S. ES Oceanography	J. Miksis-Olds
Hilary Kates Varghese *	Ph.D. ES Oceanography	J. Miksis-Olds
Katherine Kirk	Ph.D. ES Oceanography	T. Lippmann
Brandon Maingot *	Ph.D. Oceanography	J. Hughes Clarke
Mashkoor Malik (NOAA) ~	Ph.D. NRESS (rec'd 2019)	L. Mayer
Grant Milne	M.S. SMSOE Biological Sciences	J. Miksis-Olds
Coral Moreno *	Ph.D. OE	L. Mayer (Schmidt)
Tamer Nada *	Ph.D. Oceanography	C. Kastrisios/B. Calder
Ashley Norton	Ph.D. NRESS (rec'd 2019)	S. Dijkstra
Casey O'Heran *	M.S. OE Ocean Mapping	B. Calder
Alexandra Padilla *	Ph.D. OE	T. Weber
Jordan Pierce *	M.S. Oceanography	Y. Rzhanov/J. Dijkstra
Glen Rice (NOAA) * ~	Ph.D. OE Mapping	T. Weber
Jaya Roperez	M.S. OE Mapping	R. Wigley
Michael Smith *	M.S. OE Ocean Mapping (rec'd 2019)	T. Weber
Derek Sowers (NOAA) ~	Ph.D. ES Oceanography	L. Mayer
Shannon-Morgan Steele *	M.S. ES Oceanography (rec'd 2019)	T. Lyons
Andrew Stevens *	Ph.D. CS	T. Butkiewicz
Dan Tauriello	M.S. OE Mapping	B. Calder
Aditi Tripathy	Ph.D. OE	J. Miksis-Olds
Katherine Von Krusenstiern *	M.S. ES Oceanography	T. Lippmann
Elizabeth Weidner *	Ph.D. ES Ocean Mapping	T. Weber
Dylan Wilford *	M.S. Oceanography	J. Miksis-Olds

\* Funded by NOAA/JHC Source  
 ~ Part-time

## GEBCO Students (2019-2020)

Student	Institution	Country
Diego Billings	National Land Agency, Jamaica	Jamaica
Danai Lampridou	National & Kapodistrian University of Athens	Greece
Ana Carolina Lavagnino	Rede Rio Doce Mar/ RRD— a research group at Universidade Federal do Espírito Santo (UFES)	Brazil
Simitrio Morales Lopez	Mexican Navy (DIGAOHM), Directorate of Hydrography, Veracruz	Mexico
Ryosuke Nagasawa	Hydrographic and Oceanographic Department, Japan Coast Guard	Japan
Tion Uriam	Ministry of Information, Communications, Transport and Tourism Development, Kiribati	Kiribati (Micronesia)

## Appendix B: Field Programs

TSR1901 EM122 Beam Pattern Characterization, January 2–6. Acoustic testing and characterization of the radiated sound field from the 12-kHz EM122 aboard R/V *Sally Ride* at the Navy SOAR array off San Diego, CA. (Michael Smith, Anthony Lyons, Jennifer Miksis-Olds, Hilary Kates Varghese, Kevin Jerram, Tomer Ketter, Tom Weber, Larry Mayer)

SR1901 SCORE Multibeam Experiment, January 2–6. A series of experiments were completed to investigate the presence of artifacts, as well as, continue to test the feasibility of an in-field calibration methodology using a bottom mounted vertical hydrophone array. Sound level measurements were conducted utilizing both the SCORE hydrophone range and a custom mooring design from JASCO Applied Sciences. Multibeam survey operations were conducted aboard the R/V *Sally Ride* utilizing a 12kHz Kongsberg EM122. (Anthony Lyons)

Wallis Sands Beach Temperature Experiment, January 10–February 10. Obtain observations of temperature structure in the freezing and thawing beach sediments, water levels (with pressure), and beach profiles. (Jon Hunt, Tom Lippmann)

BLEA 2019 Western Florida Continental Shelf Mapping, February 1–9. High-resolution mapping of the western Florida continental shelf with Drs. Robert Ballard and Larry Mayer using a Reson T-50 dual-head MBES aboard the Florida Institute of Oceanography's vessel R/V *William T. Hogarth*. (Larry Mayer, Paul Johnson, Kevin Jerram)

EL19-IGV01 Södra Kvarken Turbulence Investigation, February 19–27. Cruise with researchers from Stockholm University investigating broadband acoustic identification of turbulent scattering phenomenon. (Elizabeth Weidner)

EL19-IGV01 Södra Kvarken Turbulence Investigation, February 19–March 3. Cruise with researchers from Stockholm University investigating broadband acoustic identification of turbulent scattering phenomenon. (Elizabeth Weidner)

Five Deeps Expedition Indian Ocean Transit Leg, February 23–March 17. Jaya Roperez worked aboard DSSV *Pressure Drop* to collect and process bathymetric and water column data, and create data products during the vessel's transit from Capetown, South Africa to Fremantle, Australia as part of the Five Deeps Expedition. The transit also included two days of mapping at the Diamantina Trench to locate the deepest point and determine which of the Diamantina and Java Trenches is deeper and will eventually be where the exploration dive of the submersible Limiting Factor will occur. CCOM provided three ocean mappers for this transit leg—all alumni of the NF/GEBCO Training Program at UNH—and funded the travel expenses to add value to the transit activity and support the Nippon Foundation-GEBCO Seabed 2030 Project mapping to fill the gaps on the ocean bathymetric data compilation. (Jaya Roperez)

Oregon Inlet Experiment, March 7–April 22. Field Experiment at Oregon Inlet, NC, for Josh Humberston's Ph.D. research. Deployed 11 in situ instruments and sediment grab samples (in addition to collaborative observations of bathymetry and radar backscatter). (Tom Lippmann)

Oyster Reef Restoration Site Surveys, April 2–30, Conduct Multibeam bathymetric surveys of oyster reef restoration areas in the Great Bay with the Zego Boat. (Tom Lippmann)

ASV-BEN Shakedown, April 8–12. A series of daily operations in Portsmouth Harbor, testing new software installed by ASV Global, new payload power distribution system, new path following algorithm, new sonar acquisition software SIS-5, new EM2040P MKII sonar head, new camera system, new Kongsberg Marine Broadband Radio telemetry system. All this with visitors from QPS for a prototype install of QINSY aboard the ASV. (Andy McLeod, Kenneth G. Fairbarn, Roland Arsenault, Lynette Davis, Coral Moreno, Val E. Schmidt)

R/V *Gulf Surveyor* Survey, April 17. LiDAR and photogrammetry surveys of the *Gulf Surveyor* were done for thesis research. (Matthew Rowell, Emily Terry, Casey O'Heran)

ASV SIS-5 and Sonar Troubleshooting, April 17–19. Testing of SIS-5, sonar operations and operation of the ASV Mobile Lab as an operational control center. (Andy McLeod, Kenneth G. Fairbarn, Coral Moreno, Roland Arsenault, Val E. Schmidt)

The Five Deeps Expedition Challenger Deep, April 24–May 9. Seabed 2030 data analyst and GEBCO alumnus Tomer Ketter has sailed aboard DSSV *Pressure Drop* to augment the bathymetric mapping effort in preparation and during the manned submersible dives to the in the Mariana trench, four of which were in Challenger Deep including a new depth record and one dive to Sirena deep. During the cruise, Ketter operated the first production version of Kongsberg EM124 multibeam echosounder to identify the deepest location for the dives and processed the data to produce bathymetric and backscatter maps to aid in the dive planning and scientific objectives of the expedition. The data acquired during the Five Deeps expedition will be included in future compilations of Seabed 2030 grids. (Tomer Ketter)

ASV Sonar Testing, April 24. Ongoing testing of SIS-5 and sonar operation in Portsmouth Harbor. (Andy McLeod, Kenneth G. Fairbarn, Roland Arsenault, Val E. Schmidt)

NA105 E/V *Nautilus* Engineering Shakedown, April 29–May 5. Quality assessment of the E/V *Nautilus*'s EM302 multibeam echosounder system. (Paul Johnson)

Thunder Bay National Marine Sanctuary Mapping, May 2–20. The ASV Group participated in a three-week mapping event on Lake Huron in collaboration with the Thunder Bay National Marine Sanctuary and the Ocean Exploration Trust. Goals of the mapping effort involved the search for unknown shipwrecks in the newly expanded sanctuary. Technical goals for the event included testing of new radio systems, new sonar systems, new ASV camera systems, new payload power distribution systems and ASV operations from shore. (Andy McLeod, Kenneth G. Fairbarn, Roland Arsenault, Lynette Davis, Coral Moreno, Val E. Schmidt)

AT42-10 EM122 / PHINS / Seapath Calibration and Accuracy Testing, May 4–8. Remote support for EM122 calibration and accuracy testing with iXBlue PHINS and Seapath 330+ positioning/motion systems aboard Woods Hole Oceanographic Institute's R/V *Atlantis*. Calibration and accuracy test plans were developed for opportunistic surveying at a suitable area on Mendocino Ridge during a vessel transit. (Kevin Jerram, Paul Johnson)

EX1902 *Okeanos Explorer* Shakedown and ROV Mobilization, May 12–24. Shannon Hoy and Derek Sowers served as Co-Expedition Coordinator for the annual shakedown cruise for NOAA Ship *Okeanos Explorer*, and took place between Pascagoula, MS and Key West, FL in the Gulf of Mexico. The primary purpose of this shakedown expedition was to test, calibrate, and integrate equipment and train personnel in order to ensure the collection of high-quality data throughout the remainder of 2019. Mapping shakedown operations during the expedition included calibrating the ship's EM302 multibeam sonar (used to map the seafloor and water column) and the EK60 split-beam sonar (used to explore the water column); integrating and calibrating a new Simrad EK80 split-beam sonar (for further water column exploration); and installing and testing a new sonar synchronization unit (K-Sync – to reduce potential interference between different sonars). Three "engineering dives," of OER's ROVs were also completed. On the last dive, a new shipwreck was unexpectedly discovered and characterized. (Shannon Hoy, Kevin Jerram, Derek Sowers)

SH 2019 Summer Hydro, May 20–July 12. The areas surveyed were all in the immediate vicinity of York, ME. Semme Dijkstra was the lead instructor. Students in the course learned about data acquisition and processing software, how to plan a survey, mobilize the R/V *Gulf Surveyor*, a tide gauge, a GNSS base station, and a drone used for obtaining shoreline aerial imagery data. (Matthew Rowell, Emily Terry, Daniel Tauriello, Will Fessenden, Semme J. Dijkstra)

GEOPATHS Sediment Sampling, May 28–31. Obtained sediment soil cores, gravity cores, and grab samples in the Great Bay and Hampton Estuaries as part of the NSF funded GEOPATHS Closes-Gap 2019 program. (Tom Lippmann)

ASV BEN EM2040 Calibration and Accuracy Testing, May 29. Geometry review, calibration ("patch test"), swath accuracy, and swath coverage testing for the EM2040 installed aboard the Center's autonomous surface vessel (ASV) BEN. (Val E. Schmidt, Kenneth G. Fairbarn, Paul Johnson, Kevin Jerram, Lynette Davis, Kevin Jerram)

ASV MAC Sonar Evaluation, May 29. Multibeam Advisory Committee evaluation of sonar acquisition and data processing for ASV-BEN, the EM2040P MKII, and SIS-5. (Kenneth G. Fairbarn, Lynette Davis, Alex Brown, Roland Arsenault, Paul Johnson, Kevin Jerram, Val E. Schmidt)

3D Mapping of Temperate Reefs, June 1–October 15. Continued testing of DSLRs in habitats dominated by macroalgae. Because macroalgae moves, 3D reconstruction is difficult. This past field season, we tested different methods of data collection for best 3D reconstruction results. (Kristen L. Mello, Jenn Dijkstra)



EchoBoat/PicoMBES Testing, June 6–7. Site visit and training at Seafloor Systems to prepare for deployment of an EchoBoat autonomous surface vessel (ASV) with PicoMBES multibeam echosounder off the Icebreaker *Oden* during the Ryder Glacier 2019 expedition. Testing of the vessel and MBES was conducted on nearby Folsom Lake. (Kevin Jerram, Sam Reed)

NA109 E/V *Nautilus*, June 9–22. Jaya Roperez joined the transit mapping of the E/V *Nautilus* from San Francisco, CA to Honolulu, HI as a mapper and navigator. Sub-bottom profile was collected using Knudsen K3260 was collected in addition to the bathymetric, backscatter and water column data from the hull-mounted EM304. Roperez was partnered with a seafloor mapping intern during daily eight-hour shift where they operated the vessel's sonar mapping systems while processing the MBES data. By the end of the transit, they also submitted a compilation of undersea features in addition to the usual products of the mapping cruise. (Jaya Roperez)

*Galen J.*, June 17–July 12. Evaluating the use of Photomosaics for Fine-Scale Mapping of Habitat Use by Commercially Valuable Species. (Kristen L. Mello, Jenn Dijkstra)

EX1903 Windows to the Deep 2019 - Leg 2, June 20–July 11. Seabed and water column mapping, subbottom profiling, and ROV exploration of poorly mapped deepwater regions off the southeastern U.S. coast aboard NOAA Ship *Okeanos Explorer*. (Shannon Hoy, Kevin Jerram)

Zego Boat Oyster Reef Surveys, July 3–October 30. MBES surveys of artificial oyster reefs in the Great Bay. (Jon Hunt, Tom Lippmann)

Errol Logjam Surveys, July 10–11. Zego Boat MBES surveys of river near Errol, NH (in collaboration with Tom Ballesterro, UNH). (Jon Hunt, Tom Lippmann)

3D Mapping of Coral Reefs, July 10–14. Collaboration with Mark Butler from Old Dominion. 2 Go-Pro Hero 7s were calibrated and mounted to a frame to create a stereo camera pair. This system was tested on patch reefs with and without macroalgae in the Florida Keys. Macroalgae is not stationary and thus provided a good comparison of model results with and without moving algae. Jordan continued to map coral reef patches until July 24. (Jordan Pierce, Colin Ware, Jenn Dijkstra)

NPP2019 Northwest Passage Project, July 17–August 5. Operated an EM122 multibeam aboard the I/B *Oden* in remote parts of the arctic region. (Tomer Ketter)

EX1904 Leg 1 *Okeanos Explorer* Technology Demonstration, July 18–24. Leg 1 operations included the deployment of a REMUS 600 Autonomous Underwater Vehicle (AUV) in partnership with the NOAA Office of Coast Survey (OCS) and a towed Kraken Robotics KATFISH™ with Synthetic Aperture Sonar in partnership with Kraken Robotics and ThayerMahan, Inc. Targets for testing these systems focused on the U.S. northeast continental shelf and will include areas with limited bathymetric coverage, Underwater Cultural Heritage sites (UCH), and sites that were identified in the 2013 NOAA report, "Risk Assessment for Potentially Polluting Wrecks in U.S. Waters." These systems will be deployed in concert with the *Okeanos Explorer's* suite of deepwater mapping systems. (Anthony Lyons)

NA112 American Samoa National Marine Sanctuary Ocean Exploration, E/V *Nautilus*, July 29–August 5. Seafloor mapping with ASV BEN from the E/V *Nautilus* and in collaboration with the American Samoan National Marine Sanctuary. (Andy McLeod, Kenneth G. Fairbarn, Lynette Davis, Val E. Schmidt)

Five Deeps Expedition - North Atlantic/Arctic Transit Mapping, August 5–23. Jaya Roperez worked twelve-hour daily shifts aboard DSSV *Pressure Drop* with Mekayla Dale (GEBCO Yr 15) who had just finished the curriculum for the NF/GEBCO Training Program at CCOM. They collected and processed bathymetric, backscatter and water column data, and created data products during the vessel's transit from Newfoundland, Canada to Svalbard, Norway for the last dive for the Five Deeps Expedition (Arctic Ocean). They also processed the sonar data from the Pacific Ocean transit (Tonga to Panama) and submitted a compilation of undersea features based on the data collected from both transit mapping legs of the expedition. The undersigned's participation to the transit mapping is supported and funded by CCOM and Dr. Wigley's grant as contribution to the Seabed 2030 Project. (Jaya Roperez)

NA113 Nikumaroro Expedition, E/V *Nautilus*, August 5–25. Ocean Exploration Trust expedition, to provide shallow water mapping, aerial photogrammetry, sub-surface photogrammetry, GPS base station and roving units all in the search for Amelia Earhart's Lockheed Electra aircraft. This expedition was sponsored by National Geographic. (Andy McLeod, Kenneth G. Fairbarn, Val E. Schmidt)

EX1905 Leg 1 Deep Connections 2019 (Mapping), NOAA Ship *Okeanos Explorer*, August 6–20, 24-hour mapping expedition, systematically surveying the canyons in the Canadian waters off of Nova Scotia. (Shannon Hoy)

Ryder19 Ryder Glacier Expedition, August 6–September 10. Expedition on the I/B *Oden* to Sherard-Osborn Fjord in Northern Greenland to map the bathymetry of the fjord and explore air-sea-ice interactions. (Larry Mayer, Brian Calder, Kevin Jerram, Elizabeth Weidner)

August 2019 Pier Survey, August 6. Collected GPS observations of ground control points located on the UNH pier. (Casey O'Heran)

August 2019 *Gulf Surveyor* Flights, August 21–23. Aerial surveys of the *Gulf Surveyor* were conducted with a drone at the UNH pier on New Castle Island, NH. (Emily Terry, Matthew Rowell, Casey O'Heran)

5 Deeps Arctic Ocean Deep Dive, August 23–September 9. Participated in the final leg of the Five Deeps Expedition aboard the DSSV *Pressure Drop*. The cruise was part of a larger expedition to send Explorer Victor Vescovo to the deepest point of each ocean. The Arctic cruise mapped the Molloy Hole and sent a submersible down to the bottom of the geological feature. (Cassandra Bongiovanni, Michael Smith)

Zego Boat Current Surveys Current Surveys, September 25–26. Conducted cross-river current surveys with Zego Boat in support of activities sponsored by Hypack (Straud Armstrong) related to autonomous surface marine vehicles. (Jon Hunt, Tom Lippmann)

FK191005 EM302/EM710 Quality Assurance Testing, October 5–8. Sensor geometry review, POS MV and Seapath antenna calibrations, geometric calibrations ('patch tests'), swath accuracy testing, swath coverage assessments, noise testing, and hardware health analyses for the EM302 and EM710 multibeam mapping systems aboard R/V *Falkor*. (Paul Johnson, Kevin Jerram)

EX1906 *Okeanos Explorer* 2019 Southeastern U.S. Deep-Sea Exploration: Mapping, October 5–26. This NOAA Ship *Okeanos Explorer* cruise began in North Kingstown, Rhode Island and ended in Miami, Florida. This dedicated mapping cruise was the first in a two-part expedition, with the follow-up ROV/Mapping cruise commencing on October 31st. The 22-day mapping cruise focused on exploratory mapping in U.S. federal waters offshore from Georgia and Florida, in the Stetson Mesa region of the Blake Plateau. New mapping data were collected in high priority areas of shared management interest to the United States Geological Survey, the Bureau of Ocean Energy Management, and the South Atlantic Fisheries Management Council. The cruise revealed many new areas of likely deep sea coral mounds, and defined the easternmost extent of dense coral mound features in the southern and middle portion of the Stetson Miami Terrace Deepwater Coral Habitat Area of Particular Concern. (Lynette Davis, Derek Sowers)

N/A DriX Trials aboard NOAA Ship *Thomas Jefferson*, October 7–18. Norfolk dockside and at-sea trials of the iXblue DriX ASV aboard NOAA Ship *Thomas Jefferson*. (Val E. Schmidt)

AR40 ADEON Cruise 4, R/V *Neil Armstrong*, October 19–November 6. The fourth of five ADEON cruise from 2017-2020. (Hilary Kates Varghese, Dylan Wilford, Jennifer Miksis-Olds)

AT42-19 BASIN 19, October 27–November 11. Research cruise in the Santa Barbara Basin with University of California Santa Barbara colleagues, studying the benthic biogeochemistry of an anoxic basin. (Elizabeth Weidner)

EX1907 2019 Southeast Mapping and ROV Exploration, NOAA Ship *Okeanos Explorer*, October 31–November 20. Mapping and ROV exploration in the Southeast and Straits of Florida. (Shannon Hoy)

November 2019 *Gulf Surveyor* Flight, November 7. An aerial survey of the *Gulf Surveyor* was conducted with a drone at the UNH pier on New Castle Island, NH. (Matthew Rowell, Casey O'Heran)

AR41 EM122/EM710 Quality Assurance Testing, November 18–22. Geometry review, hardware testing, and swath coverage assessment for the EM710 and EM122 multibeam mapping systems aboard R/V *Neil Armstrong*. Operational areas included the continental shelf break south of Woods Hole, MA. A patch test was completed for the EM710; the calibration planned for the EM122 was cancelled due to heavy seas and reduced cruise duration. A POS MV GAMS calibration was performed prior to all testing. (Paul Johnson, Kevin Jerram)

## Appendix C: Partnerships and Ancillary Programs

One of the goals of the Joint Hydrographic Center is, through its partner organization the Center for Coastal and Ocean Mapping, to establish collaborative arrangements with private sector and other government organizations. Our involvement with Tyco has been instrumental in the University securing a \$5 million endowment; \$1 million of this endowment has been earmarked for support of post-doctoral fellows at the Center for Coastal and Ocean Mapping. Industrial Partner Kongsberg Maritime has also provided \$1 million to support the research of John Hughes Clarke. Our interaction with the private sector has been formalized into an industrial partner program that is continually growing.

- Acoustic Imaging Pty LTD
- Alidade Hydrographic
- AML Oceanographic
- Anthropocene Institute
- Applanix
- ASV Global Ltd.
- BAE Systems
- Chesapeake Technology, Inc.
- Clearwater Seafoods
- David Evans & Associates
- Earth Analytic, Inc.
- Edgetech
- Eiva Marine Survey Solutions
- Environmental Systems Research Institute
- Exocetus Autonomous Systems
- Farsounder, Inc.
- Fugro USA Marine, Inc.
- Higgs Hydrographic Tek
- Hydroid (Subsidiary of Kongsberg)
- Hypack, A Xylem Brand
- IFremer
- IIC Technologies
- iXblue S.A.S.
- Jasco Applied Sciences (Canada) Ltd.
- Klein Marine Systems, Inc.
- Kongsberg Underwater Technology
- Leidos
- Marine Advanced Robotics, Inc.
- Norbit Subsea
- Ocean Exploration Trust
- OHTI (Ocean High Technology Institute)
- Phoenix International
- QPS
- Saildrone
- Sea Machines Robotics
- Sea ID, Ltd.
- SevenCs
- Seismic Micro Technology Kingdom
- SubCom
- Substructure
- Survice Engineering Company
- Teledyne Marine
- Teledyne Optech
- Triton Imaging, Inc.
- Tycom, Ltd.

### In addition, grants are in place with:

- City of Portsmouth, NH
- Department of Commerce
- Department of Defense, Office of Naval Research
- Department of Energy, Los Alamos National Laboratory
- Department of the Interior
- Exxon Corporation
- Kongsberg Maritime
- National Science Foundation
- Nature Conservancy (from U.S. Department of Agriculture)
- NH Sea Grant
- Nippon Foundation/GEBCO
- Ocean Exploration Trust
- PADI Foundation
- Schmidt Ocean Institute
- TE Connectivity
- TYCO
- University of California at Santa Barbara (from CA State Lands Commission)
- United Kingdom Hydrographic Office
- University of New Hampshire Sea Grant
- University of Rhode Island (from NOAA)



The Center has also received support from other sources of approximately \$5,333,991 for 2019 (see below).

Project Title	PI	Sponsor	CY Award 2019	Total Award	Length
IT Support for NOAA UNH Employees	Calder, B.	U.S. DOC, NOAA	59,163	222,800	3 years
IT Support for NOAA UNH Employees	Calder, B.	U.S. DOC, NOAA	9,379	9,379	1 year
Cycle of Ice-Ocean Interactions Using Autonomous Platforms	Chayes, D.	U.S. DOD, Office of Naval Research	24,511	509,920	5 years
Comparing Abundance of Oyster Larvae and Recruitment in the Great Bay Estuary	Dijkstra, J.	City of Portsmouth		8,000	1 year
Oyster Larvae and Recruitment	Dijkstra, J.	NH Sea Grant (US DOC, NOAA)	5,000	5,000	1 year
Comparison between Oyster Larvae and Recruitment	Dijkstra, J.	Nature Conservancy		2,500	5 months
Integrated Multibeam	Hughes Clarke, J.	Kongsberg Maritime	-	1,000,000	5 years
Sustained Real-time Turbidity NFE	Hughes Clarke, J.	Exxon Corp	130,000	190,000	3.5 months
Coastal Processes and Sediment Transport	Humberston, J.	PADI Foundation		3,900	1 year
Supporting the Multibeam Sonar Systems of the US Academic Research Fleet	Johnson, P.	National Science Foundation	108,350	775,191	4 years
Schmidt Ocean Institute 2019	Johnson, P.	Schmidt Ocean Institute	30,195	30,195	7 months
Collaborative Research: Optimization of the Multibeam Sonar Systems of the US Academic Fleet through Coordinated system Testing, Tool Development, and Community Outreach	Johnson, P.	National Science Foundation	148,103	838,835	5 years
Temperature Structure in Frozen Sediments	Lippmann, T	NH Sea Grant (US DOC, NOAA)		7,421	1 year
Bathymetric Surveys in Support of Oyster Reef Restoration	Lippmann, T	Nature Conservancy (US Dept of Agriculture)	20,044	100,094	18 months
UNH Oceanography Graduate Program	Lippmann, T	TE Connectivity	10,000	10,000	1 year
Potential Impacts of Climate Change-Induced Changes in Temperature	Lippmann, T	U.S. DOC, NOAA	44,563	44,563	2 years
Imaging SAS Performance Estimation	Lyons, A.	U.S. DOD, Office of Naval Research		214,998	4 years
SAS Analysis, Scattering Mechanisms	Lyons, A.	U.S. DOD, Office of Naval Research	75,000	449,946	3.5 years
Experimental Measurements High-Frequency Scattering	Lyons, A.	U.S. DOD, Office of Naval Research	208,000	414,000	3 years
Measuring and Modeling Temporal Changes in Seafloor Scatter	Lyons, A.	U.S. DOD, Office of Naval Research	290,000	830,000	3 years
Establishing and maintaining network for Seabed 2030	Mayer, L.	GEBCO-Nippon Foundation		1,056,000	1 year
Seabed 2030: Complete Mapping of the Ocean Floor by 2030	Mayer, L.	Stockholm Univ., (GEBCO-Nippon Foundation)	10,000	122,150	39 months

NF GEBCO Years 13 & 14 Project & Travel	Mayer, L.	GEBCO Nippon-Foundation		1,258,397	3 years
NF GEBCO Years 15 & 16 Project & Travel	Mayer, L.	GEBCO Nippon-Foundation		1,368,920	1 year
NF GEBCO Years 6-10 Project & Travel	Mayer, L.	GEBCO Nippon-Foundation		2,754,455	13 years
Indian Ocean Project	Mayer, L.	GEBCO Nippon-Foundation		245,269	7 years
NF GEBCO Ambassador	Mayer, L.	GEBCO Nippon-Foundation		40,500	3 years
NF GEBCO Year 11 Project & Travel	Mayer, L.	GEBCO Nippon-Foundation		630,000	4 years
NF GEBCO Year 12 Project & Travel	Mayer, L.	GEBCO Nippon-Foundation		604,301	3 years
NFE Ocean Exploration Cooperative Institute (OECI)	Mayer, L.	Univ of Rhode Island (USDOC, NOAA)	1,111,439	7,288,485	21 months
ASV Exploration	Mayer, L.	Ocean Exploration Trust	166,227	166,227	14 months
Tyco Endowment	Mayer, L.	TYCO	51,315	-	<i>in perpetuity</i>
Saildrone Surveyor: Autonomous Mapping & Environmental Characterization Using Deep Ocean ASV	Mayer, L.	U.S. DOC, NOAA	999,852	999,852	3 years
Monitoring Odontocete Shifts	Miksis-Olds, J.	U.S. DOD, Office of Naval Research	200,000	800,000	5.4 years
Large Scale Density Estimation of Blue and Fin Whales	Miksis-Olds, J.	U.S. DOD, Office of Naval Research	53,510	266,396	2.5 years
Exploitation of the CTBTO Hydro-Acoustic Array Data Bases	Miksis-Olds, J.	U.S. DOD, Office of Naval Research		120,000	3 years
SeaBASS 2018: BioAcoustic Summer School	Miksis-Olds, J.	U.S. DOC, NOAA		30,500	3.5 years
ADEON: Atlantic Deepwater Ecosystem Observatory Network	Miksis-Olds, J.	U.S. DOI, Dept. of the Interior	1,087,181	6,092,513	5 years
Deep Water Atlantic Habitats	Miksis-Olds, J.	TDI Brooks (Dept. of the Interior)	83,023	383,911	4.5 years
Seafloor Video Mosaic Research (under 115122)	Rzhanov, R.	US DOI, US Geological Survey		19,615	5 years
NH Beach Volunteer Beach Profiling Year 4	Ward, L.	NH DES (NOAA)	34,263	54,836	1 year
Assessment of Offshore Sources-Extension	Ward, L.	U.S. DOI, BOEM		499,997	4 years
Continuously-Running, Asynchronous Sampling Engine	Ware, C.	U.S. DOE, Los Alamos National Laboratory	56,846	180,000	2.5 years
Development of a Broadband	Weber, T.	National Science Foundation	78,753	690,785	5 years
Platform Holly Seep Acoustic Observatory	Weber, T.	UC Santa Barbara (CA State Lands Commission)	128,163	145,594	1 year
3rd NOAA Chart Adequacy Eval	Wigley, R.	U.K. Hydrographic Office		45,000	24 months
GEBCO-NF Team Participation in the Shell Ocean Discovery XPRIZE	Wigley, R.	GEBCO-Nippon Foundation	111,111	3,362,581	14 months
GEBCO-NFE Shell Ocean Discovery Xprize Round 2	Wigley, R.	GEBCO-Nippon Foundation		3,092,801	15 months
<b>TOTALS</b>			<b>5,333,991</b>	<b>37,985,827</b>	

## Appendix D: Publications

### Book Section

Sowers, D., Dijkstra, J.A., Masetti, G., Mayer, L.A., Mello, K., and Malik, M.A., "Applying a Standardized Classification Scheme (CMECS) to Multibeam Sonar and ROV Video Data on Gosnold Seamount," in *Seafloor Geomorphology as Benthic Habitat: GeoHab Atlas of Seafloor Geomorphic Features and Benthic Habitat*, 2nd ed., Elsevier Inc., 2019, p. 1076.

### Conference Abstracts

Lowell, K. and Calder, B.R., "Improving Extraction of Bathymetry from Lidar Using Machine Learning," 20th Annual Coastal Mapping and Charting Workshop of the Joint Airborne Lidar Bathymetry Technical Center of Expertise (JALBTCX). Notre Dame, IN, 2019.

Malik, M.A., Masetti, G., Schimel, A.C.G., Roche, M., Dolan, M., and Le Deunf, J., "Preliminary Evaluation of Multi-beam Backscatter Consistency through Comparison of Intermediate Processing Results," GeoHab 2019 - BSWG Meeting. Saint Petersburg, Russia, 2019.

Malik, M.A., Masetti, G., Schimel, A.C.G., Roche, M., Dolan, M., and Le Deunf, J., "Preliminary Evaluation of Multi-beam Backscatter Consistency Through Comparison of Intermediate Processing Results," U.S. Hydro 2019. Biloxi, MS, 2019.

D. Manda and Masetti, G., "Pydro & HydrOffice: Open Tools for Ocean Mappers," U.S. Hydro 2019. Biloxi, MS, 2019.

Masetti, G., Augustin, J.-M., Malik, M.A., Poncelet, C., Lurton, X., Mayer, L.A., Rice, G.A., and Smith, M., "The Open Backscatter Toolchain (OpenBST) Project: Towards an Open-Source and Metadata-Rich Modular Implementation," U.S. Hydro 2019. Biloxi, MS, 2019.

Masetti, G., Faulkes, T., and Calder, B.R., "Opening the Black Boxes in Ocean Mapping: Design and Implementation of the HydrOffice Framework," AMSA 2019. Freemantle, WA, Australia, 2019.

Sowers, D., Masetti, G., Mayer, L.A., Johnson, P., Gardner, J.V., and Armstrong, A.A., "Adding Value to Broad-Scale Ocean Exploration Mapping Data Through Standardized Geomorphic Classification and Backscatter Data Analysis," 2019 Fall Meeting, American Geophysical Union (AGU). San Francisco, CA, 2019.

Ward, L.G., "Assessing the Stability of New Hampshire Beaches: Research Involving the University of New Hampshire, New Hampshire State Agencies, and Citizen Scientists," The Beaches Conferences 2019: Our Maine and New Hampshire Beaches and Coast. Kittery, ME, 2019.

Ward, L.G., McAvoy, Z.S., Masetti, G., and Morrison, R.J., "High Resolution Mapping of Morphologic Features and Seafloor Sediments of the New Hampshire and Vicinity Continental Shelf, Western Gulf of Maine," Geological Society of America (GSA) Annual Meeting, Northeastern Section. Portland, ME, 2019.

Ward, L.G., McAvoy, Z.S., Corcoran, N.W., Masetti, G., Johnson, P., and Morrison, R.J., "High-Resolution Surficial Geology Mapping of the New Hampshire Inner Continental Shelf and Coastline: An Important Step Towards Coastal Resiliency," Gulf of Maine 2050 International Symposium. Portland, ME, 2019.

### Conference Proceedings

Butkiewicz, T., Stevens, A.H., and Ware, C., "Multi-touch 3D Positioning with the Pantograph Technique," ACM SIGGRAPH Symposium on Interactive 3D Graphics and Games, vol. 13. ACM, Montreal, Quebec, Canada, 2019.

Calder, B.R. "Resolution Determination through Level of Aggregation Analysis," U.S. Hydro 2019. Biloxi, MS, 2019.



- Hoy, S. and Calder, B.R., "The Viability of Crowdsourced Bathymetry for Authoritative Use," U.S. Hydro 2019. Biloxi, MS, 2019.
- Kastrisios, C., Calder, B.R., Masetti, G., and Holmberg, P., "On the Effective Validation of Charted Soundings and Depth Curves," U.S. Hydro 2019. Biloxi, MS.
- Kastrisios, C., Calder, B.R., Masetti, G., and Holmberg, P., "Validation of the Shoal-Biased Pattern of Bathymetric Information on Nautical Charts," 29th International Cartographic Conference (ICC 2019), vol. 1. International Cartographic Association, Tokyo, Japan, 2019.
- Lowell, K. and Calder, B.R., "Machine Learning Strategies for Enhancing Bathymetry Extraction from Imbalanced Lidar Point Clouds," Oceans '19. IEEE, Seattle, WA, 2019.
- Maingot, B., Hughes Clarke, J.E., and Calder, B.R., "High Frequency Motion Residuals in Multibeam Data: Identification and Estimation," Proc. U.S. Hydro 2019. Biloxi, MS, 2019.
- Masetti, G., Faulkes, T., and Kastrisios, C., "Hydrographic Survey Validation and Chart Adequacy Assessment Using Automated Solutions," U.S. Hydro 2019. Biloxi, MS, 2019.
- Masetti, G. and Faulkes, T., "Pydro and HydrOffice," Effective Seabed Mapping Workflow. Canberra, ACT, Australia, 2019.
- Moreno, C., Schmidt, V.E., Calder, B. R., and Mayer, L.A., "Sensing for Hydrographic Autonomous Surface Vehicles," U.S. Hydro 2019. Biloxi, MS, 2019.
- Schmidt, V.E., and Downs, R., "Operations of an Autonomous Surface Vehicle Aboard the NOAA Ship *Fairweather*," U.S. Hydro 2019. Biloxi, MS, 2019. p. 13, 2019.
- Stevens, A.H. and Butkiewicz, T., "Reducing Seasickness in Onboard Marine VR Use through Visual Compensation of Vessel Motion," IEEE Virtual Reality 2019, Workshop on Immersive Sickness Prevention. IEEE, Osaka, Japan, 2019.

## Journal Articles

- Ballard, R., Mayer, L.A., Broad, K., Coleman, D.F., Heffron, E., and Schmidt, V.E., "Walking with the Ancients" in the Southern California Continental Borderland," *Oceanography*, vol. 32(1). The Oceanography Society, pp. 54-55, 2019.
- Calder, B.R., "Parallel Variable-Resolution Bathymetric Estimation with Static Load Balancing," *Computers and Geosciences*, vol. 123. Elsevier, pp. 72-82, 2019.
- Dijkstra, J.A., Litterer, A., Mello, K., O'Brien, B., and Rzhanov, Y., "Temperature, Phenology, and Turf Macroalgae Drive Seascape Change: Connections to Mid-trophic Level Species," *Ecosphere*, vol. 10(11). Ecological Society of America. 2019.
- Eakins, B., Gottfried, S., Murphy, P., Loyalvo, D., and Sowers, D., "It Takes a Village! Managing Data from *Okeanos Explorer*," *Oceanography*, vol. 32(1). pp. 106-109, 2019.
- Eren, R., Jung, J., Parrish, C.E., Forfinski, N., and Calder, B.R., "Total Vertical Uncertainty (TVU) modeling for topobathymetric lidar systems," *Photogrammetric Engineering and Remote Sensing*, vol. 85. American Society for Photogrammetry and Remote Sensing, pp. 585-596, 2019.
- Fakiris, E., Blondel, P., Papatheodorou, G., Christodoulou, D., Dimas, X., Georgiou, N., Kordella, S., Dimitriadis, C., Rzhanov, Y., Geraga, M., and Ferentinos, G., "Multi-Frequency, Multi-Sonar Mapping of Shallow Habitats—Efficacy and Management Implications in the National Marine Park of Zakynthos, Greece," *Remote Sensing*, vol. 11(4). p. 461, 2019.

- Gales, J.A., Talling, P.J., Cartigny, M.J.B., Hughes Clarke, J.E., Lintern, G., Stacey, C.D., and Clare, M.A., "What Controls Submarine Channel Development and the Morphology of Deltas Entering Deep-Water Fjords?" *Earth Surface Processes and Landforms*, vol. 44(2). John Wiley and Sons Ltd., pp. 535-551, 2019.
- Gee, L., Heffron, E., Raineault, N.A., Turchik, A., Mittelstaedt, E., Hourigan, T., and Cormier, M.H., "Contributing to Global Seabed Mapping Initiatives: *Nautilus* Maps Remote Pacific Areas," *Oceanography*, vol. 32(1). The Oceanography Society, pp. 38-39, 2019.
- Hage, S., Cartigny, M.J.B., Sumner, E., Clare, M.A., Hughes Clarke, J.E., Talling, P.J., Lintern, G., Simmons, S., Jacinto, R., Vellinga, A., Allin, J., Azpiroz-Zabala, M., Gales, J., Hizzett, J., Hunt, J., Mozzato, A., Parsons, D., Pope, E., Stacey, C.D., Symons, W., Vardy, M., and C., W., "Direct Monitoring Reveals Initiation of Turbidity Currents From Extremely Dilute River Plumes," *Geophysical Research Letters*, vol. 46(20). pp. 11310-11320, 2019.
- Howe, B., Miksis-Olds, J., Rehm, E., Sagen, H., Worcester, P.F., and Haralabus, G., "Observing the Oceans Acoustically," *Frontiers in Marine Science*, vol. 6. p. 426, 2019.
- Kastrisios, C., Calder, B.R., Masetti, G., and Holmberg, P., "Towards Automated Validation of Charted Soundings: Existing Tests and Limitations," *Geo-spatial Information Science*. Taylor & Francis, 2019.
- Kates Varghese, H., Smith, M., Miksis-Olds, J., and Mayer, L.A., "Mapping Multibeam Echo Sounders—A Square Peg in a Round Hole," *Journal of Ocean Technology*, vol. 14. Fisheries and Marine Institute of Memorial University of Newfoundland, pp. 41-46, 2019.
- Miksis-Olds, J., Harris, D., and Heaney, K., "Comparison of Estimated 20-Hz Pulse Fin Whale Source Levels from the Tropical Pacific and Eastern North Atlantic Oceans to Other Recorded Populations," *Journal of the Acoustical Society of America*, vol. 146. Acoustical Society of America, pp. 2373-2384, 2019.
- Moore, J.T., Miller, J.H., Potty, G.R., Tripathy, A., Tazawa, M., Amaral, J., Newhall, A.E., and Lin, Y.-T., "Estimation of Environmental Parameters with Machine Learning Using a Compact Tetrahedral Array and Sources of Opportunity," *The Journal of the Acoustical Society of America*, vol. 145(3). Acoustical Society of America, pp. 1671-1671, 2019.
- Normandeau, A., Dietrich, P., Hughes Clarke, J. E., Van Wychen, W., Lajeunesse, P., Burgess, D., and Ghienne, J.-F., "Retreat Pattern of Glaciers Controls the Occurrence of Turbidity Currents on High-Latitude Fjord Deltas (Eastern Baffin Island)," *Journal of Geophysical Research: Earth Surface*, vol. 124(6). pp. 1559-1571, 2019.
- Sautter, L., Morrison, C. L., Cantwell, K., Sowers, D., and Lobecker, E., "Windows to the Deep 2018: Exploration of the Southeast U.S. Continental Margin," *Oceanography*, vol. 32(1). pp. 82-85, 2019.
- Seger, K.D. and Miksis-Olds, J., "Acoustic Documentation of Temperate Odontocetes in the Bering and Chukchi Seas," *Marine Mammal Science*, vol. 35. Society for Marine Mammalogy, pp. 1099-1111, 2019.
- Soule, S.A., Heffron, E., Gee, L., Mayer, L.A., Raineault, N.A., German, C.R., Lim, D.S.S., Zoeller, M., and Parcheta, C., "Mapping the Lava Deltas of the 2018 Eruption of K lauea Volcano," *Oceanography*, vol. 32(1). The Oceanography Society, pp. 46-47, 2019.
- Sowers, D., White, M., Malik, M., Lobecker, E., Hoy, S., and Wilkins, C., "NOAA Ship *Okeanos Explorer* 2018 Ocean Mapping Achievements," *Oceanography*, vol. 32(1). pp. 92-95, 2019.
- Sowers, D., Malik, M., Lobecker, E., and White, M., "Over a Decade of Training the Next Generation: the Explorer-in-Training Program," *Oceanography*, vol. 32(1). pp. 114-115, 2019.
- Vendettuoli, D., Clare, M.A., Hughes Clarke, J.E., Vellinga, A., Hizzet, J., Hage, S., Cartigny, M.J.B., Talling, P.J., Waltham, D., Hubbard, S.M., Stacey, C.D., and Lintern, D.G., "Daily Bathymetric Surveys Document How Stratigraphy is Built and Its Extreme Incompleteness in Submarine Channels," *Earth and Planetary Science Letters*, vol. 515. Elsevier, pp. 231-247, 2019.

- Ware, C., Dijkstra, J.A., Mello, K., Stevens, A.H., O'Brien, B., and Ikedo, W., "A Novel Three Dimensional Analysis of Functional Architecture that Describe the Properties of Macroalgae as Refuge," *Marine Ecology Progress Series*, vol. 608. pp. 93-103, 2019.
- Weidner, E., Weber, T.C., Mayer, L.A., Jakobsson, M., Chemykh, D., and Semiltov, I., "A Wideband Acoustic Method for Direct Assessment of Bubble-Mediated Methane Flux," *Continental Shelf Research*, vol. 173. Elsevier, pp. 104-115, 2019.
- Wilson, N., Parrish, C.E., Battista, T., Wright, C.W., Costa, B., Slocum, R., Dijkstra, J.A., and Tyler, M.T., "Mapping Seafloor Reflectance and Assessing Coral Reef Morphology with EAARL-B Topographic Lidar Waveforms," *Estuaries and Coasts, Special Issue: Shallow Water Mapping*, Springer, 2019.
- Wöfl, A.-C., Snaith, H., Amirebrahim, S., Devey, C. W., Dorschel, B., Ferrini, V. L., Huvenne, V.A. I., Jakobsson, M., Jencks, J., Johnston, G., Lamarche, G., Mayer, L.A., Millar, D., Pedersen, T., Picard, K., Reitz, A., Schmitt, T., Visbeck, M., Weatherall, P., and Wigley, R., "Seafloor Mapping – The Challenge of a Truly Global Ocean Bathymetry," *Frontiers in Marine Science*, vol. 6(283). p. 283, 2019.

## Conference Poster

- Kane, R., Gee, L., Roman, C., Schmidt, V.E., Sudek, M., Spathias, H., Coward, G., and Raineault, N.A., "E/V *Nautilus*: Seafloor Exploration and Mapping in the National Marine Sanctuary of American Samoa," 2019 Fall Meeting, American Geophysical Union (AGU). San Francisco, CA, 2019.

## Reports

- Engstrom, S. and Sullivan, B. M., "NIPWG6-35.1 S-125 Navigational Services status update," International Hydrographic Organization (IHO), Rostock, Germany, 2019.
- Sullivan, B.M., "NIPWG6-08.1 - Status report on the development of S-126: Marine Physical Environment," International Hydrographic Organization (IHO), Rostock, Germany, 2019.
- Sullivan, B.M., "NIPWG6-5.3 NOAA's NPB progress on transitioning from paper products to S-100 products (progress on interoperability between CP and ENC)," International Hydrographic Organization (IHO), Rostock, Germany, 2019.
- Sullivan, B.M., "NIPWG7-48.2\_Creation and storage of S-127 (Marine Traffic Management) for U.S. Waters." International Hydrographic Organization (IHO), Tallinn, Estonia, 2019.
- Sullivan, B.M., "NIPWG7-8.1 The History and Status of S-126 Marine Physical Environment," International Hydrographic Organization (IHO), Tallinn, Estonia, 2019.

## Master's Theses

- Maingot, B., *High Frequency Motion Residuals: Analysis and Estimation*, University of New Hampshire, Durham, NH, 2019.
- Smith, M. *Analysis of the Radiated Soundfield of a Deep Water Multibeam Echosounder Using a Submerged Navy Hydrophone Array*, University of New Hampshire, Durham, NH, 2019.
- Steele, S.M., *Development and Experimental Validation of End-Fire Synthetic Aperture Sonar for Sediment Scattering Studies*, University of New Hampshire, Durham, NH, 2019.



## Appendix E: Technical Presentations and Seminars

Brian Calder, Invited, February 21, Mapping for Shoals to Deep, and Sparse to Dense, UNH Department of Earth Sciences, Chapman Colloquium, Durham, NH. Discussion of the difficulties faced in transforming raw ocean mapping bathymetric data into useful information and products.

Brian Calder, Invited, March 12, New Approaches to Bathymetric Lidar Data Processing, UJNR/JHOD, UJNR Meeting 2019, Tokyo, Japan. Description of adaptation of acoustic processing methods (specifically CHRT) for lidar data from the Riegl VQ-880-G topobathymetric lidar system, including the use of a machine learning technique to pre-filter hypotheses before reconstruction, thereby cleaning up the data reconstruction considerably.

Brian Calder, Contributed, March 20, Resolution Determination through Level of Aggregation Analysis, 2019 U.S. Hydrographic Conference, Biloxi, MS. Description of the use of Level of Aggregation Analysis in determining the appropriate resolution at which to work for depth estimation, with applications to acoustic surveys and Seabed 2030.

Brian Calder, Invited, May 27, Computer-assisted Bathymetric Processing, Uncertainty Representation, and Resolution, Université Laval, Summer School on Hydrography and Lidar, Québec City, QC, Canada. Overview of computer-assisted processing methods for bathymetry, and the various trade-offs and requirements to support them in practice. Given as part of the Summer School in Hydrography and Lidar at Laval University.

Brian Calder, Invited, March 13, Autonomous Systems Development at NOAA-UNH Joint Hydrographic Center, UJNR/JHOD, UJNR Meeting 2019, Tokyo, Japan. Calder presented an overview of current research in ASVs at JHC on behalf of Val Schmidt.

Brian Calder, Contributed, June 5, Improving Extraction of Bathymetry from Lidar Using Machine Learning, Joint Airborne Lidar Bathymetry Technical Center of Expertise (JALBTCX), JALBTCX workshop, Notre Dame, IN. Overview of use of multiple different machine learning techniques to model the bathymetric signal in metadata from Riegl VQ-800-G topobathymetric lidar data.

Brian Calder, Invited, October 24, Examination of NMEA Data Loggers for Crowdsourced Bathymetry, International Hydrographic Organisation Data Quality Working Group, Crowd-source Bathymetry Working Group 5, Monaco. Report on the testing done on serial and CANbus data loggers to collect NMEA data (0183 and 2000 respectively) for crowdsourced bathymetry. This is in connection with the SB2030 mandate to use CSB for data collection, as implemented with NCEI.

Brian Calder, Invited, October 22, Technical Panel on CSB, Seabed 2030, From Vision to Action, London, England. Invited technical panel discussion on the hardware/software models for future CSB and alternative method data collection to support the Seabed 2030 initiative.

Jenn Dijkstra, Contributed, April 3–7, Turf Macroalgae Enhance Habitat Fragmentation and Negatively Affect Fish Abundance, Benthic Ecology Meeting, St. John's, NF, Canada. Presented study which serves to identify the degree to which turf algae affect the spatial organization of temperate reef seascapes and the distribution of fish species.

Jenn Dijkstra, Contributed, April 3–7, Evaluating and Monitoring Coral Reef Habitats with Airborne LIDAR Systems, Benthic Ecology Meeting, St. John's, NF, Canada. Presented study results indicating that LIDAR waveform features may be useful to identify dominant coral inhabitants and prevalence of dominant reef morphotype, and that LIDAR waveform features can potentially be used to detect changes in benthic habitats over 10-100s of meters.

Jenn Dijkstra, Contributed, April 3–7, Global Domination: Using Species Distribution Models to Understand the Spread of Two Invasive Seaweeds, Benthic Ecology Meeting 2019, St. John's, NF, Canada.

Jenn Dijkstra, Invited, September 20, Ocean Warming Effects of Gulf of Maine Benthic Communities, Emery University Department of Environmental Sciences Seminar, Atlanta, GA. Presentation about how ocean warming is affecting the ecology and function of Gulf of Maine benthic communities.

Jenn Dijkstra, Invited, December 10, Using Acoustic Mapping Technology to Understand the Gulf of Maine Ecosystem, Center for Acoustic, Research and Education (CARE) Seminar, University of New Hampshire Durham, NH.

Jenn Dijkstra, Invited, November 18, Ocean Warming Effects of Gulf of Maine Benthic Communities, UNH Freshman Zoology Class, Durham, NH.

Shannon Hoy, Contributed, March 19, The Viability of Crowdsourced Bathymetry for Authoritative Use, 2019 U.S. Hydrographic Conference, Biloxi, MS. Presented a section of her thesis, The Viability of Crowdsourced Bathymetry to demonstrate and defend that while CSB is currently unable to meet charting, hydrographic offices have a responsibility to report dangers to navigation to the mariner and, therefore, must incorporate CSB into the chart. A recommended method for how to accomplish this—The Shoal Accepting Method—was presented.

Shannon Hoy, Contributed, October 23, NOAA Ship *Okeanos Explorer* Sonar Synchronization, RVTEC 2019, Fairbanks, AK. Presented the results of the synchronization work performed during the EX1902 Shakedown Expedition in the MAC breakout session.

Paul Johnson, Invited, October 23, Multibeam Advisory Committee (MAC) Breakout Session, Research Vessel Technical Enhancement Committee, RVTEC 2019, Anchorage, AK. Presentation on how to conduct a shipboard assessment of a multibeam echosounder system, a review of the activities of the MAC over the last year, and an examination of some of the tools available for assessing multibeam and aiding in mapping.

Paul Johnson, Invited, June 18, System Acceptance and Quality Assurance Testing of Multibeam Echosounder Systems in the U.S. Academic Fleet, Geoscience Australia, AusSeabed-OCS-CCOM Workshop, Canberra, Australia.

Paul Johnson, Tomer Ketter, Invited, November 9, North Pacific Regional Assembly and Coordination Center, Arctic-Antarctic Seabed 2030 WG, Portsmouth, NH. Showed status and workflow of the creation of the new North Pacific bathymetric grid delivered to Seabed 2030 and GEBCO.

Tara Johnson, Contributed, April 10–13, National Science Teachers Association Annual Conference, St. Louis, MO. Presented in both the marine education (NMEA Section) and in the Middle School educators share-a-thon. Talked about the upcoming conference (NMEA 2019) and the Seacoast SeaPerch program.

Christos Kastrisios, Contributed, March 19, On the Effective Validation of Charted Soundings and Depth Curves, 2019 U.S. Hydrographic Conference, Biloxi, MS. Presented on the problem of automating the validation of shoal-selected soundings, proposing a new validation test, named Nautical Surface Test, which captures the local morphology at the appropriate charting resolution as the solution for the automated validation of the charted bathymetric information.

Christos Kastrisios, Contributed, July 18, Validation of the Shoal-Biased Pattern of Bathymetric Information on Nautical Charts, 29th International Cartographic Conference (ICC 2019), Tokyo, Japan. Presentation given at the ICC2019 in Tokyo on our research work on the validation of the shoal-biased pattern of selection for the charted soundings.

Tomer Ketter, Invited, November 7, Expanding Horizons for Ocean Mapping, GEBCO, Map the Gaps, Portsmouth, NH. Description of volunteer activities of the GEBCO program alumni.

Tom Lippmann, Invited, June 11, Webinar for NOAA Coastal Resiliency, NOAA NERACOOS NROC, Durham, NH. Panelist for NOAA Webinar on Coastal Resiliency.

Tom Lippmann, Keynote, November 5, Effects of Sea Level Rise on Modeled Storm Surge and Current Speeds in New Hampshire Estuaries, GOMRI, GOM 2050 Symposium, Portland, ME. Plenary talk on the effects of SLR on modeled storm surge and current speeds in the Great Bay and Hampton/Seabrook estuaries.

Brandon Maingot, Keynote, May 2, High Frequency Motion Residuals in Multibeam Data: Identification and Estimation, UNH School of Marine Science and Ocean Engineering Graduate Research Symposium, Durham, NH.

Giuseppe Masetti, Invited, January 22, BRESS, Deltares visit, Durham, NH. Description of the BRESS algorithm.

Giuseppe Masetti, Contributed, February 12, Sound Speed Manager and SmartMap, NOAA Office of Coast Survey (OCS), Kongsberg, NAVO, KM/UNH/UNH/NOAA/NAVO Workshop, Durham, NH. Presented an overview of Sound Speed Manager and SmartMap and previewed of coming improvements to both tools.

Giuseppe Masetti, Invited, March 26, Sound Speed Manager and SmartMap, UWDC, UWDC - CCOM/JHC Meeting, Durham, NH. Overview and future work for Sound Speed Manager and SmartMap tools.

Giuseppe Masetti, Invited, April 26, Sound Speed Manager and SmartMap, iXblue-CCOM/JHC Meeting, Durham, NH. Overview of Sound Speed Manager and SmartMap tools.

Giuseppe Masetti, Invited, June 18–20, AusSeabed-OCS-CCOM Workshop, Geoscience Australia, Canberra, Australia. Training for the Pydro and HydrOffice frameworks, live demonstrations, and behind the scenes of the software architecture. Based on learnings from the workshop and the expertise of all participants, the last session of the workshop focused on planning the best way forward in developing the QA/QC component of the AusSeabed Data Hub.

Larry Mayer, Contributed, December 9, Adding Value to Broad-scale Ocean Exploration Mapping Data Through Standardized Geomorphic Classification and Backscatter Data Analysis, American Geophysical Union 2019 Fall Meeting, San Francisco, CA.

Larry Mayer, Contributed, December 9, Evolving Arctic Bathymetry: The International Bathymetric Chart of the Arctic Ocean (IBCAO) Version 4.0 Compiled Under the Auspices of the Nippon Foundation-GEBCO-Seabed 2030 Project, American Geophysical Union 2019 Fall Meeting, San Francisco, CA.

Larry Mayer, Invited, December 5, Water Column Mapping in the Arctic: Gas Seeps and Oceanography, Arctic 5 Conference, Colorado Springs, CO.

Larry Mayer, Invited, December 4, Seabed2030 and IBCAO 4.0, Arctic 5 Conference, Colorado Springs, CO.

Larry Mayer, Invited, December 3, Mapping the Fjords of Northwestern Greenland to Understand the History of the Greenland Ice Sheet, Arctic 5 Conference, Colorado Springs, CO.

Larry Mayer, Keynote, November 21, Challenges of Arctic Mapping: A Practitioner's Perspective, National Geospatial Agency, Springfield, VA.

Larry Mayer, Keynote, October 22, Accelerating Seabed2030 Progress Through Technological Innovation, Royal Society of London, United Kingdom.

Larry Mayer, Invited, September 16, The Geospatial Context for all Ocean Observations, Ocean Obs 2019, Honolulu, HI.

Larry Mayer, Keynote, July 24, From Deepwater Horizon to the Arctic Ocean: Exploring the Secrets of the Deep, National Marine Science Educators Annual Meeting, Durham, NH.

Larry Mayer, Invited, May 14, A Geospatial Context for Everything, World Maritime University, 43rd Conference of the Center of Ocean Law and Policy, Malmo, Sweden.



Larry Mayer, Invited, April 9, A First-Hand Look at a Melting Arctic, 3rd ASIAQ Meeting, Durham, NH.

Larry Mayer, Invited, March 26, UNH Center for Coastal and Ocean Mapping/Joint Hydrographic Center, Overview of Activities, Naval Undersea Warfighters Center, Newport, RI.

Larry Mayer, Keynote, March 12, Scientific Ocean Drilling: A Long-term View, 25th Anniversary of the Bremen ODP/IODP Core Repository, Bremen, Germany.

Larry Mayer, Invited, March 4, UNH Center for Coastal and Ocean Mapping/Joint Hydrographic Center, Future Focus Areas, Hydrographic Services Review Panel, Washington, DC.

Larry Mayer, Invited, March 4, UNH Center for Coastal and Ocean Mapping/Joint Hydrographic Center, Overview and Accomplishments, Hydrographic Services Review Panel, Washington, DC.

Larry Mayer, Invited, February 26, Article 76 of the Law of the Sea Treaty, Yale University School of Law, New Haven, CT.

Larry Mayer, Invited, February 19, Ocean Mapping: Exploring the Rest of the Earth, Dept. of Geosciences, Stanford University, Stanford, CA.

Jennifer Miksis-Olds, Contributed, May 2, The Contribution of 12 kHz Multibeam Sonar to a Southern California Marine Soundscape, UNH School of Marine Science and Ocean Engineering Graduate Research Symposium, Durham, NH.

Jennifer Miksis-Olds, Contributed, May 29, The Effect of Multibeam Mapping Activity on Beaked Whale Foraging in Southern California, Northeast Regional Environmental Acoustics Symposium, Providence, RI.

Jaya Roperez, Invited, November 13–15, The Nippon Foundation/GEBCO Training Programme's Impact on Global Ocean Science Education, GOSE, 2019 Global Ocean Science Education (GOSE) Workshop, Reston, VA. Student presentation highlighting the success of the Nippon Foundation/GEBCO Training Program and how it helps individuals contribute to their home countries and to the ocean science community after the 12-month training.

Jennifer Miksis-Olds, Contributed, May 13–17, The Contribution of 12 kHz Multibeam Sonar to a Southern California Marine Soundscape, 177th Meeting of the Acoustical Society of America, Louisville, KY.

Alexandra Padilla, Contributed, May 13, Target Strength Measurements of Spherical and Wobbly Bubbles, Acoustical Society of America, Louisville, KY. Presented the preliminary results of the estimates of target strength of gas bubbles using a low frequency constant beamwidth transducer. The experimental results were compared to two different analytical target strength models. The material presented in the conference is part of Padilla's Ph.D. thesis work.

Val E. Schmidt, Contributed, March 20, Operations Of an Autonomous Surface Vehicle Aboard the NOAA Ship *Fairweather*, 2019 U.S. Hydrographic Conference, Biloxi, MS. Presented on the first deployment of an ASV by NOAA's Office of Coast Survey in the Arctic.

Val E. Schmidt, Invited, November 1, Technologies to Support Autonomous Surface Vehicle Operations for Ocean Mapping, Wooster Polytechnical Institute, Logon Speaker Series, Wooster, MA. An overview of the state of the art and new technologies being developed at the Center for autonomous vehicle operations for ocean mapping.

Val E. Schmidt, Invited, November 6, Deploying Unmanned Systems from Small Boats, NOAA Small Boat Summit, St. Petersburg, FL. An overview of technologies, regulations, methods, best practices and experience in operation of unmanned underwater and surface vehicles.

Val E. Schmidt, Contributed, November 22, Autonomous Systems for Seafloor Mapping, JHC/CCOM-Ocean Engineering Seminar Series, Durham, NH. An overview of recent ASV expeditions, the state of the art, and new technologies being developed within the ASV Group at the Center with a special behind-the-scenes look at the Center's participation in the Amelia Expedition, sponsored by National Geographic and the Ocean Exploration Trust.

Derek Sowers, Contributed, December 9, Adding Value to Broad-scale Ocean Exploration Mapping Data Through Standardized Geomorphic Classification and Backscatter Data Analysis, American Geophysical Union 2019 Fall Meeting, San Francisco, CA. Presented a methodology to generate geomorphology and predicted substrate spatial datasets using semi-automated classification methods that are transparent and repeatable, and utilize the standardized classification scheme CMECS (Coastal and Marine Ecological Classification Standard).

Derek Sowers, Invited, February 15, NOAA Ship *Okeanos Explorer*: Ten Years of Ocean Exploration Accomplishments and Highlights from the 2018 Field Season, JHC/CCOM Seminar Series, Durham, NH. An overview of ten years of NOAA's Office of Ocean Exploration and Research (OER) work with the NOAA Ship *Okeanos Explorer*.

Andrew Stevens, Contributed, October 29, Faster Multibeam Sonar Data Cleaning: Evaluation of Editing 3D Point Clouds using Immersive VR, IEEE MTS, IEEE Oceans, Seattle, WA. Presentation about a human factors study that compares 3D point cloud editing performance between a traditional interface and type types of immersive virtual reality interfaces.

Briana Sullivan, Contributed, January 28, Coast Pilot Workshop - Data Structures, MRN and Interoperability, IHO Nautical Information Provision Working Group (NIPWG), NIPWG6, Rostock, Germany, This presentation was a report from a workshop led by UNH and held at NPB in November 2018 to begin the process of implementing a data-centric production system

Briana Sullivan, Contributed, February 25–March 1, The S-111 and S-126 Interoperability Example and Status Report, IHO Nautical Information Provision Working Group (NIPWG), NIPWG6, Rostock, Germany. The S-111 (surface currents modeled data - streamlines) and S-126 (nautical textual information about surface currents) combined for the first time in a visualization within a Google maps prototype overlaid on a nautical chart. Also a status report on the progress of work/research being done on the foundation of the S-126 (physical environment) product.

Briana Sullivan, Contributed, April 8–12, The S-111 and S-126 Interoperability Example, IHO Tides Water-level Currents Working Group (TWCWG), TWCWG4, Busan, Republic of Korea. The S-111 (surface currents modeled data - streamlines) and S-126 (nautical textual information about surface currents) combined for the first time in a visualization within a Google maps prototype overlaid on a nautical chart.

Briana Sullivan, Contributed, April 10, Coast Pilot/Textual Information with the S-111 Data, IHO Tides Water-level Currents Working Group (TWCWG), TWCWG4, Busan, South Korea. An overview of the work being done at CCOM that integrates the S-111 surface current data with Coast Pilot textual information relating to surface currents (S-126). A first look at the interoperability between two different dataset in two different IHO groups.

Briana Sullivan, Contributed, November 28, 7-8.1\_S-126\_History\_Status, IHO Nautical Information Provision Working Group (NIPWG), NIPWG7, Tallinn, Estonia. Outlined the lineage of the development of the S-126 Physical Environment product specification, suggested a big picture view of the direction of the S-126, as well as provided a record the current challenges and offer possible solutions.

Briana Sullivan, Contributed, November 28, 48.2\_Creation and Storage of S-127 for U.S. Waters, IHO, NIPWG7, Tallinn, Estonia. A report of UNH's efforts to not only create the product from the U.S. Coast Pilot, but to also create a database storage system that would be able to automatically produce this product.

Larry Ward, Contributed, March 18, High Resolution Mapping of Morphologic Features and Seafloor Sediments of the New Hampshire and Vicinity Continental Shelf, Western Gulf of Maine, Geological Society of America (GSA) Annual Meeting, Northeastern Section, Annual Meeting, Portland, ME. Presented on new surficial geology maps that focus on morphologic features (geoforms), classification of the grain size of surficial sediment, and description of selected sand and gravel deposits—representing a major advance in our efforts to understand and characterize the New Hampshire and vicinity continental shelf.

Larry Ward, Contributed, June 14, Assessing the Stability of New Hampshire Beaches: Research Involving the University of New Hampshire, New Hampshire State Agencies, and Citizen Scientists, The Beaches Conference 2019: Our Maine and New Hampshire Beaches and Coast, Kittery, ME. Presented an overview of the studies of NH beaches, emphasizing results from the VBPMF.

Larry Ward, Contributed, November 4, High-Resolution Surficial Geology Mapping of the New Hampshire Inner Continental Shelf and Coastline: An Important Step Towards Coastal Resiliency, Gulf of Maine Council on the Marine Environment, Gulf of Maine 2050 International Symposium, Portland, ME. Presentation on how mapping the surficial geology of the NH coast and continental shelf, along with existing and new high-resolution topography and bathymetry surveys, will help coastal managers, planners, and the public prepare for sea-level rise and climate change, and build coastal resiliency.

Colin Ware, Invited, November 9, The Global Geographic Grid System, Arctic-Antarctic Seabed 2030 WG Meeting, Portsmouth, NH. A presentation of the Global Geographic Grid System for Visualizing Bathymetry.

Colin Ware, Jenn Dijkstra, Contributed, January 25, Measuring the Spatial Structure of Seaweed Habitats in a Changing Environment: Implications for the Food Web, JHC/CCOM Seminar Series, Durham, NH.

Colin Ware, Invited, March 19, Cognitive Efficiency and Roles for Visual Thinking Tools, MIT Center for Research on Equitable and Open Scholarship, CREOS Lecture Series, Cambridge, MA. Presented principles for visualization-based visual thinking tools.

Colin Ware, Invited, March 29, Cognitive Efficiency and Roles for Visual Thinking Tools, College of Architecture, Texas A&M University, Gieseke Lecture, College Station, TX. A discussion of principles for Visualization-based visual thinking tools.

Colin Ware, Invited, April 25, Predictive Cognition, Mental Model Building and Story Telling with Data, North Carolina State University, Symposium on Story Telling with Data, Raleigh, NC. An introduction to perceptual principles relating to storytelling with data.

Colin Ware, Invited, April 23, Predictive Cognition, Mental Model Building and Story Telling With Data, NCSU, Symposium on Story Telling With Data, Raleigh, NC. An introduction to the cognitive science of storytelling. Three science stories are used to illustrate. A fisheries model, humpback whale behavior, and seaweed architectures.

Colin Ware, Keynote, June 4, Human Perception and Visual Thinking Tools for Environmental Science, EuroVis Conference, Enviris Symposium, Porto, Portugal. A presentation of visualization principles relevant to environmental science.

Elizabeth Weidner, Contributed, April 2, Broadband Acoustic Observations of Individual, Naturally Occurring, Hydrate-Coated Bubbles in the Gulf of Mexico, UNH Graduate Research Conference, Durham, NH. Presented a dataset that supports detailed modeling of the effects of hydrate coatings on acoustic response and provides an opportunity to estimate the dissolution rate of naturally occurring hydrate-coated bubbles.



Elizabeth Weidner, Contributed, April 4, Broadband Acoustic Observations of Individual, Naturally Occurring, Hydrate-Coated Bubbles in the Gulf of Mexico, UNH Graduate Research Conference, Durham, NH. Presented on the theory that surfactants may increase the longevity of gas bubbles that escape the seafloor.

Elizabeth Weidner, Contributed, May 24, TAN1806-QUOI Voyage Results, JHC/CCOM QUOI "pop-up" presentation, Durham, NH. Special "pop-up" seminar given with Geoffroy Lemarche to the Center staff, researchers, and students covering the preliminary results of the QUOI voyage.

Elizabeth Weidner, Contributed, December 5, Tracking the Spatiotemporal Variability of the Oxic-Anoxic Interface in the Baltic Sea With Broadband Acoustics, 178th Meeting of the Acoustical Society of America, San Diego, CA. Presented methodological development of high resolution anoxic layer tracking with the concurrent study of oceanographic and biological features using broadband acoustics opens up a new level of understand of fine-scale ecosystem interactions.

Rochelle Wigley, Contributed, July 1–6, Cascading the GEBCO Seabed 2030 Project Towards a Regional Collaboration and Coordination Approach to Build a Bathymetric Map for the WIO Region, WIOMSA 11th Scientific Symposium, Réduit, Mauritius. WNF/GEBCO Alumni, led a special session.

Rochelle Wigley, Contributed, July 26, Nippon Foundation-GEBCO Seabed 2030 Project: Links with Nippon Foundation-GEBCO Training Program Alumni, NOAA's 2019 Nautical Cartography Open House, Silver Spring, MD.

Rochelle Wigley, Invited, October 8–9, The GEBCO-Nippon Foundation Alumni Team's Success Story: Winners of the Shell Ocean Discovery XPRIZE Challenge, 10th IHO-IAG ABLOS Conference, Monaco. Presentation about how the GEBCO-Nippon Foundations Alumni Team proved that diversity is a strength as they successfully met the challenges set by the Shell Ocean Discovery XPRIZE Challenge.



NOAA-UNH Joint Hydrographic Center  
Center for Coastal and Ocean Mapping

Jere A. Chase Ocean Engineering Lab

24 Colovos Road

Durham, NH 03824

603.862.3438 tel

603.862.0839 fax

[www.ccom.unh.edu](http://www.ccom.unh.edu)



**Principal Investigators**

Larry A. Mayer

Brian Calder

John Hughes Clarke

James Gardner

Colin Ware

Thomas Weber

**Co-PIs**

Thomas Butkiewicz

Jenn Dijkstra

Semme Dijkstra

Paul Johnson

Christos Kastrisios

Thomas Lippmann

Kim Lowell

Anthony Lyons

Jennifer Miksis-Olds

Giuseppe Masetti

Yuri Rzhanov

Val Schmidt

Briana Sullivan

Larry Ward

